

Проектная работа: «Графики улыбаются»

Цель работы: повторить и закрепить знания, полученные в ходе изучения графиков функций и их преобразований.

Выполнила:

Синяк Елизавета 10
класс МБУ СШ № 72

Проверила:

Колотилина Елена Аркадьевна
КРАСНОЯРСК 2017 г

Данная работа является результатом проекта по теме: “Преобразование графиков различных функций”. Она дала возможность не только показать свои знания по данному материалу, но и проявить творчество, показывая постепенное превращение задумки автора в законченную картину. На каждом этапе показана область определения соответствующей части графика функции. Работа выполнена с привлечением компьютерной программы для построения графиков функций.

I этап «Волны»

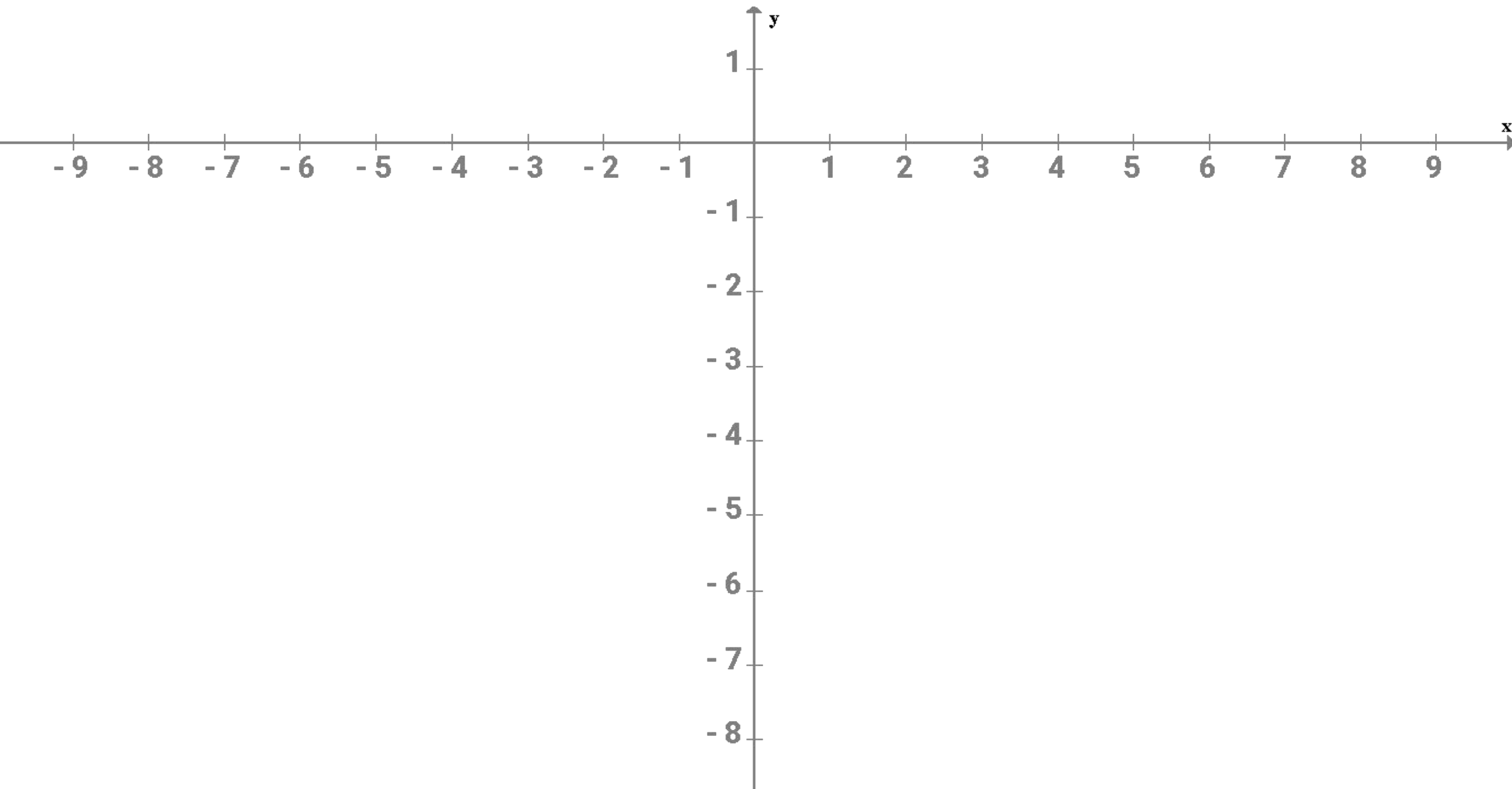

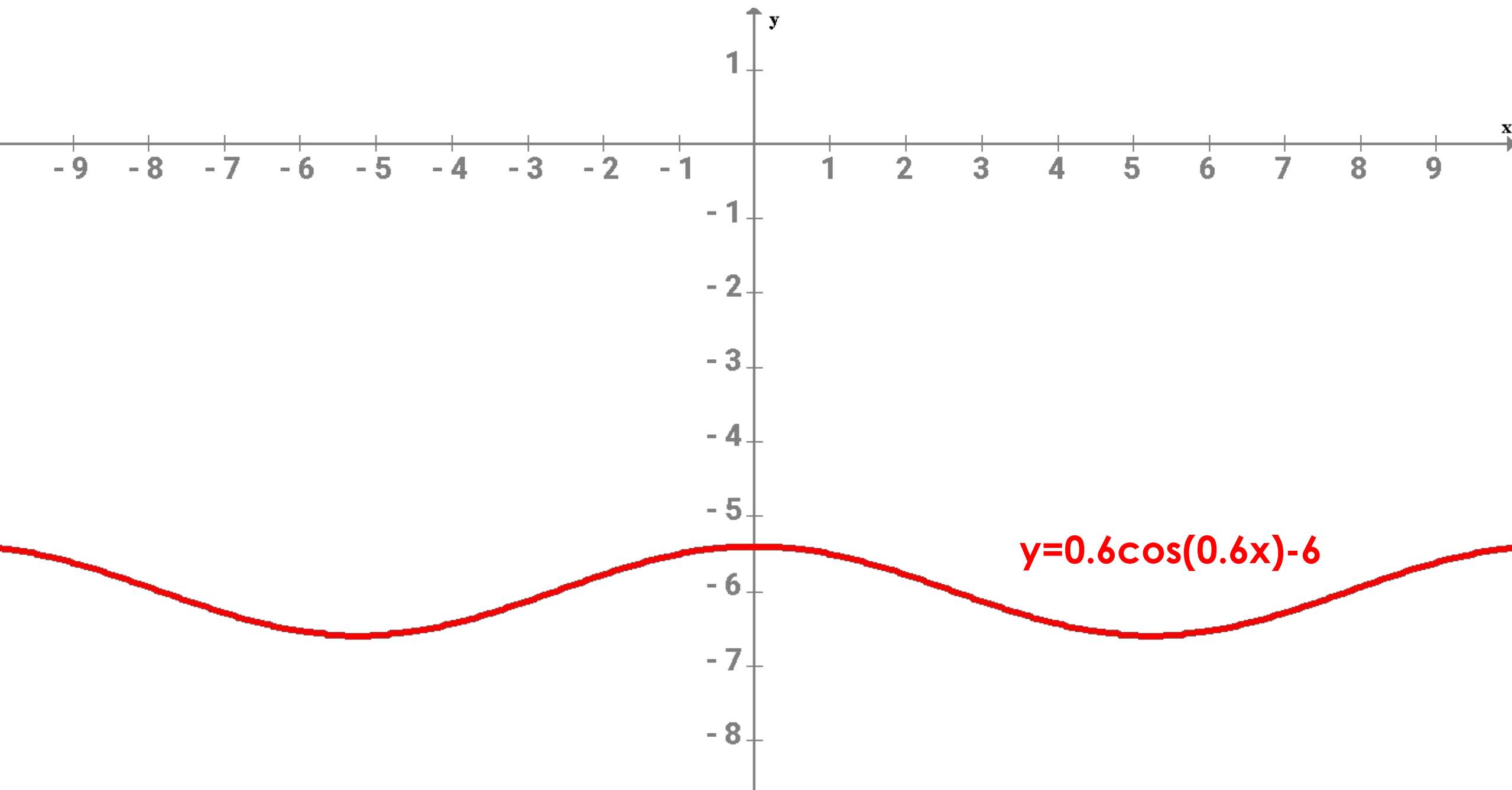

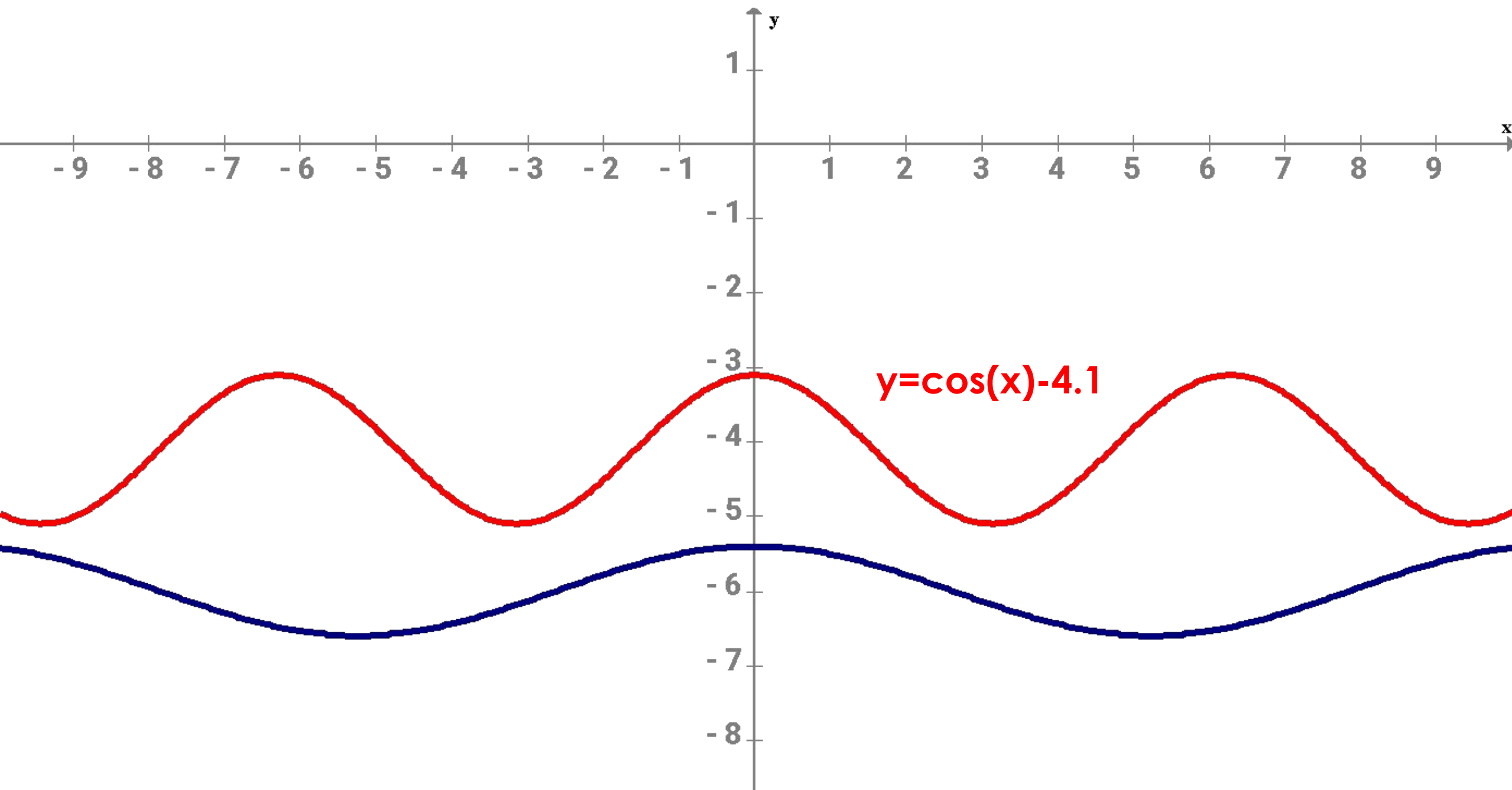

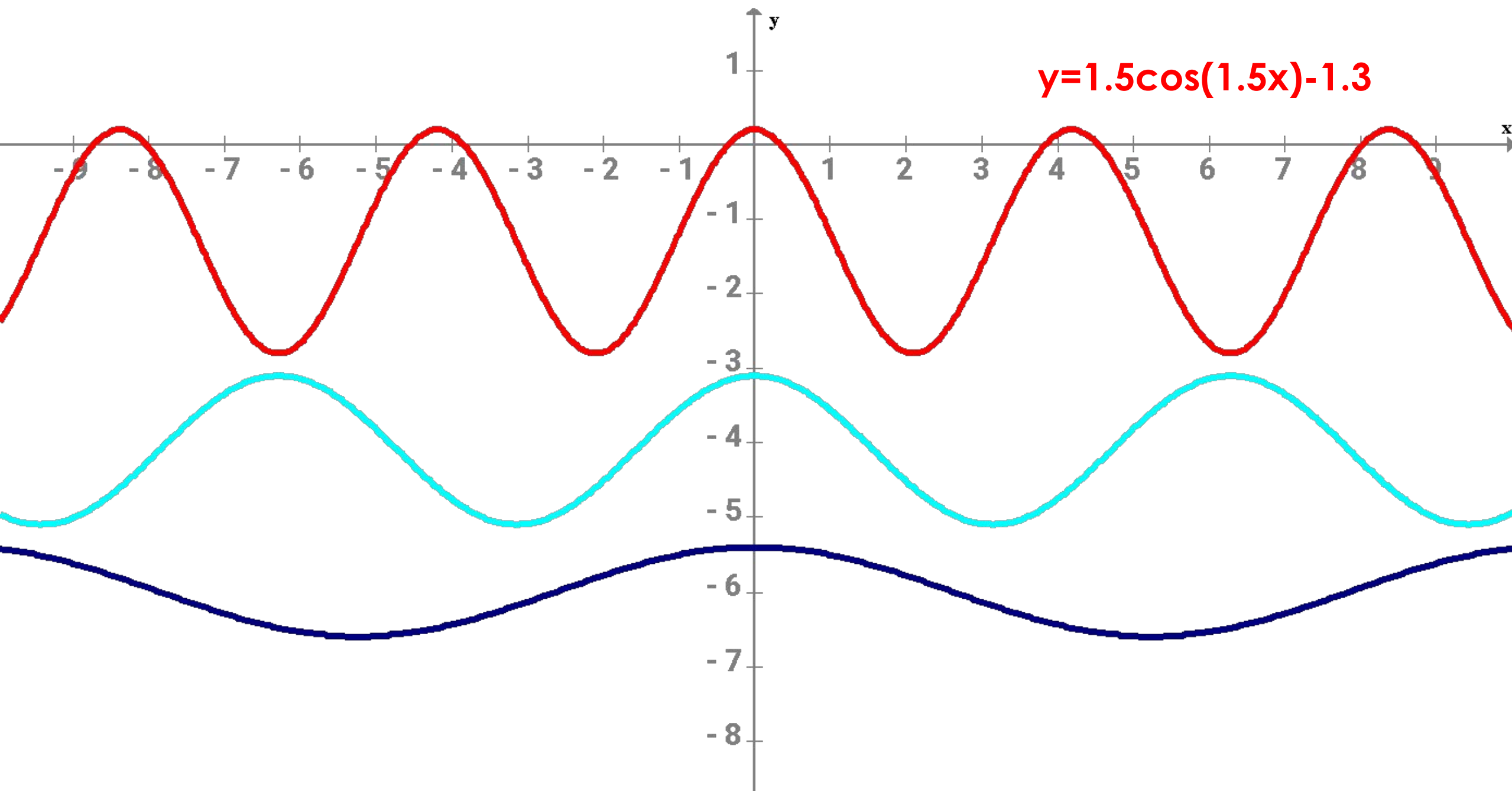

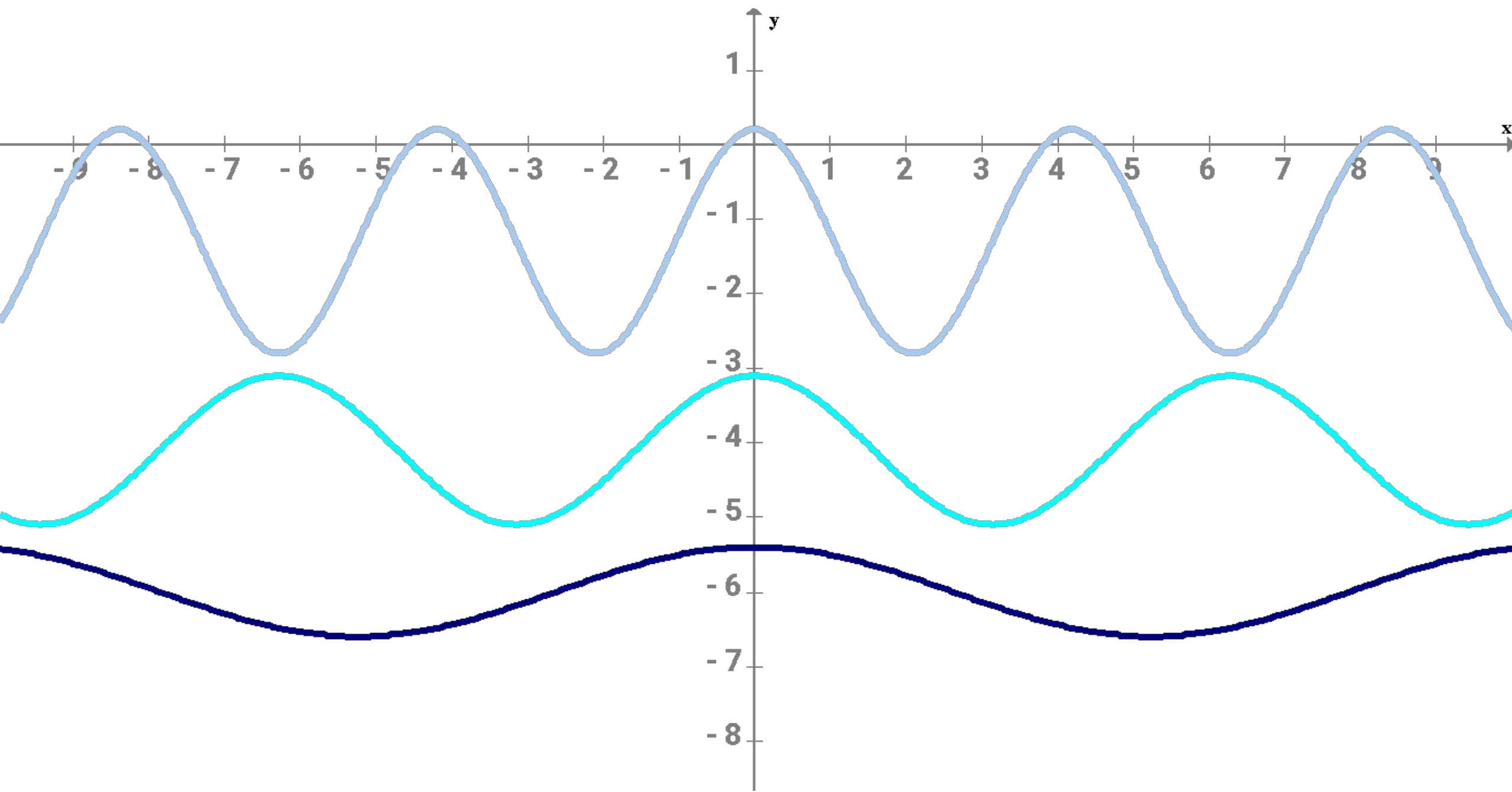

II этап «Корпус»

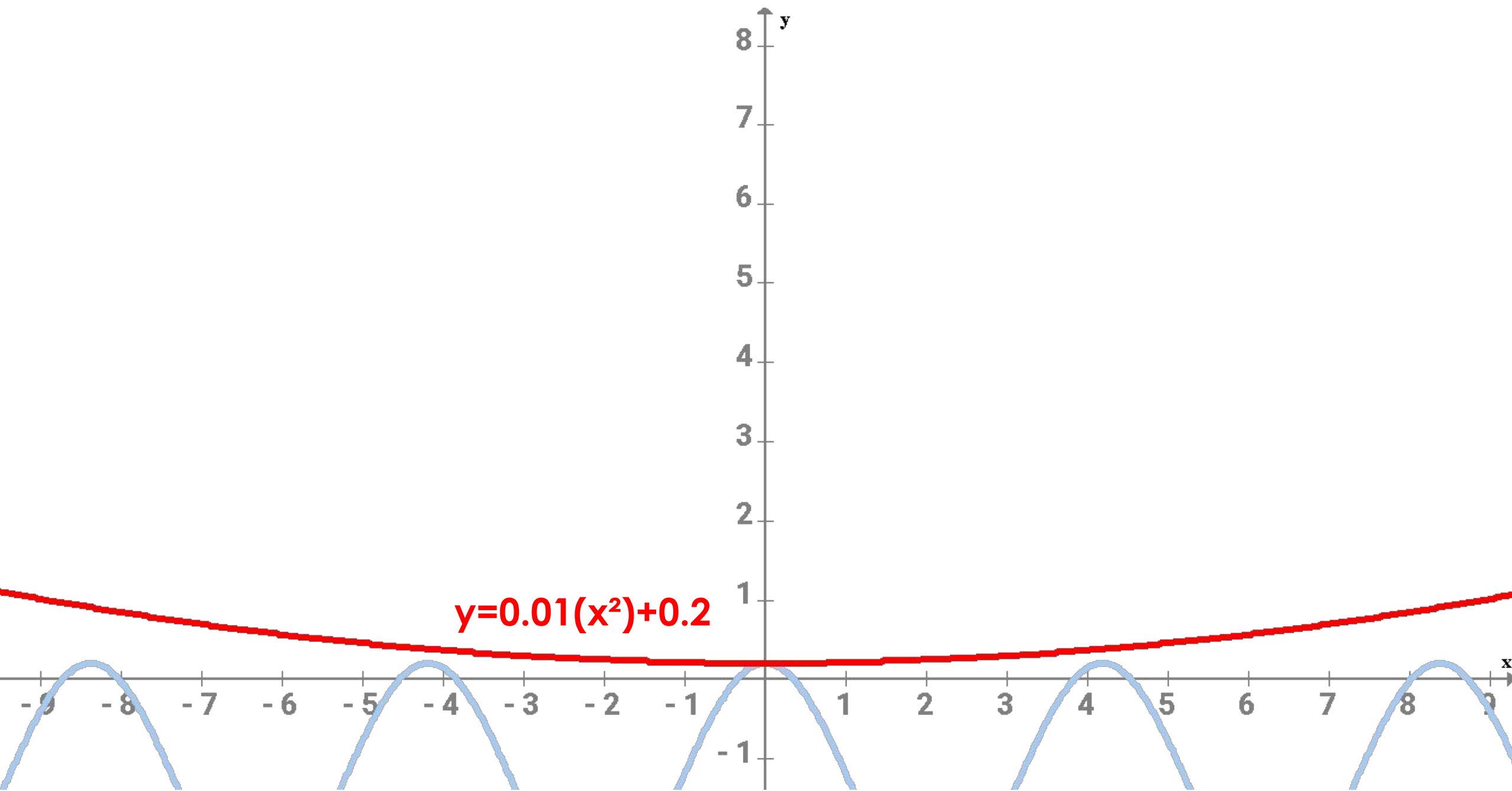

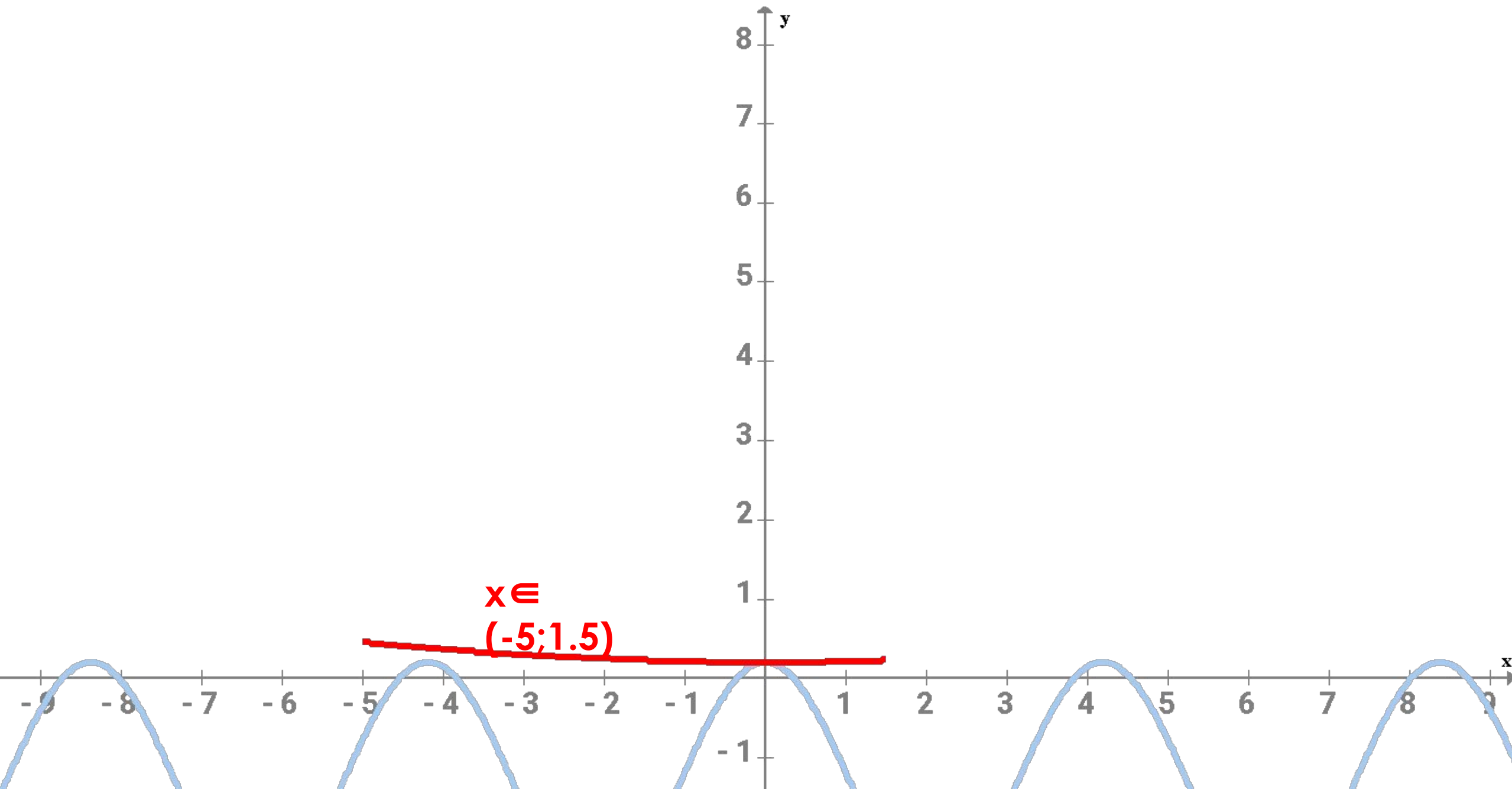

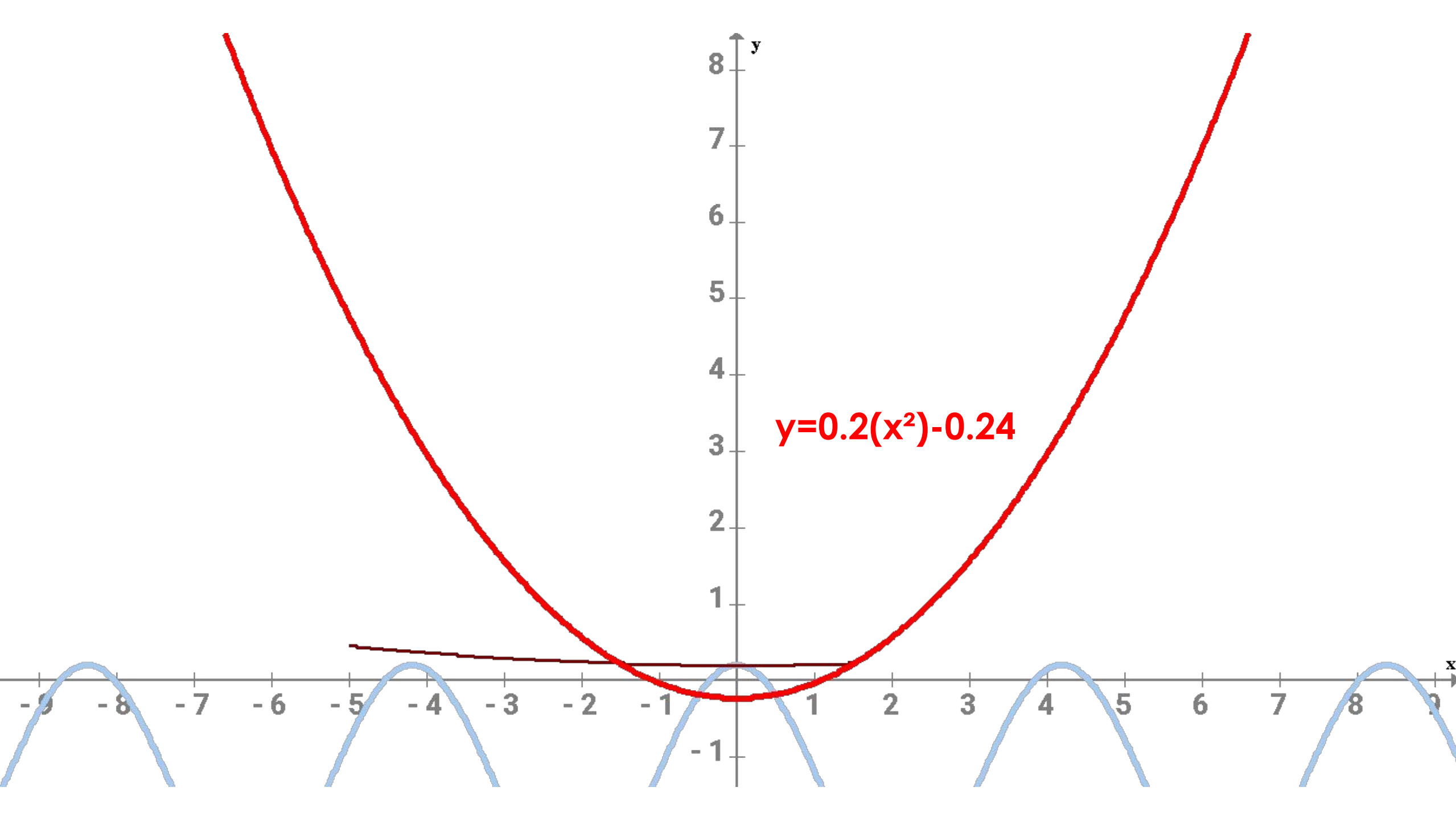

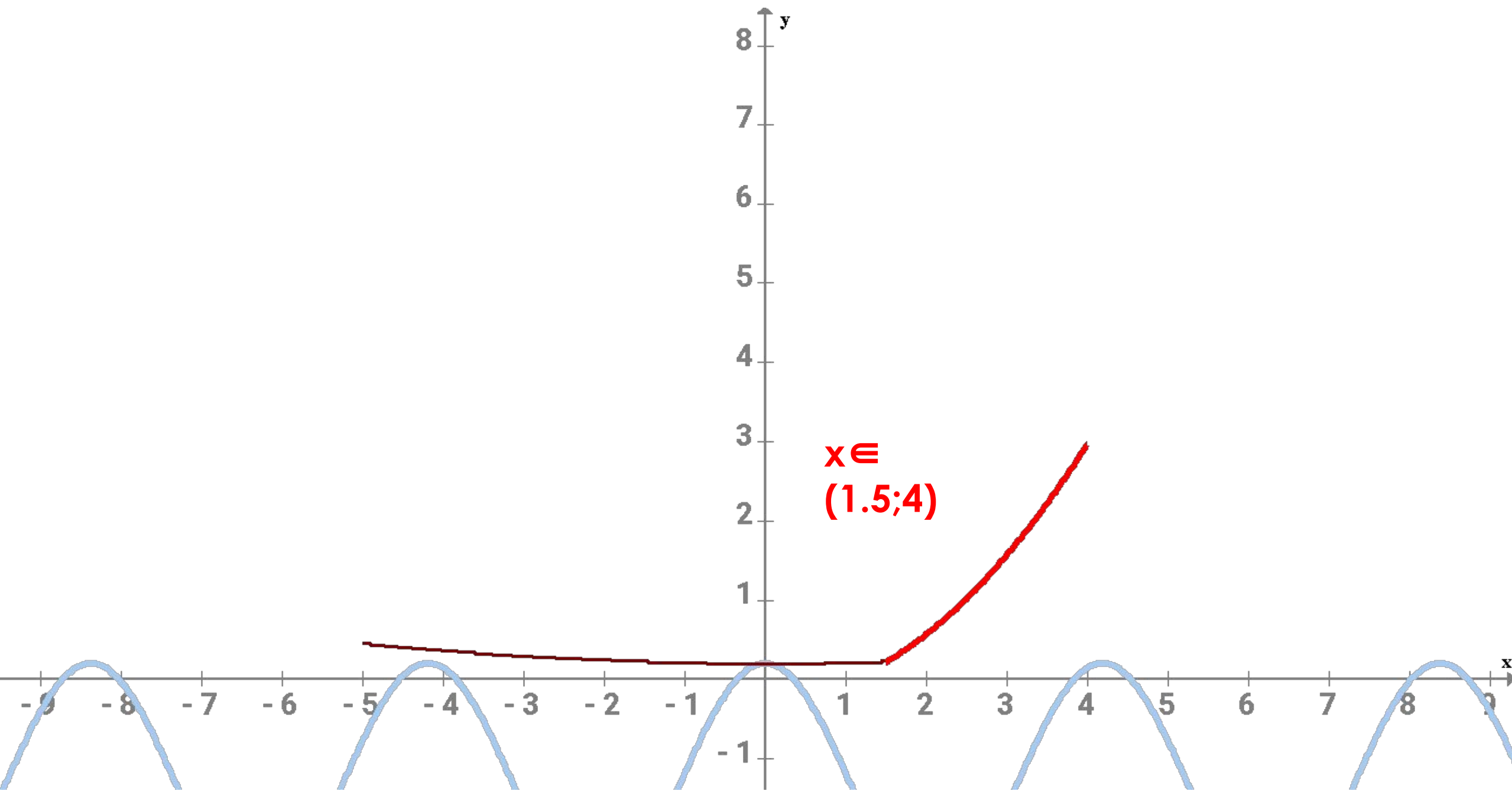

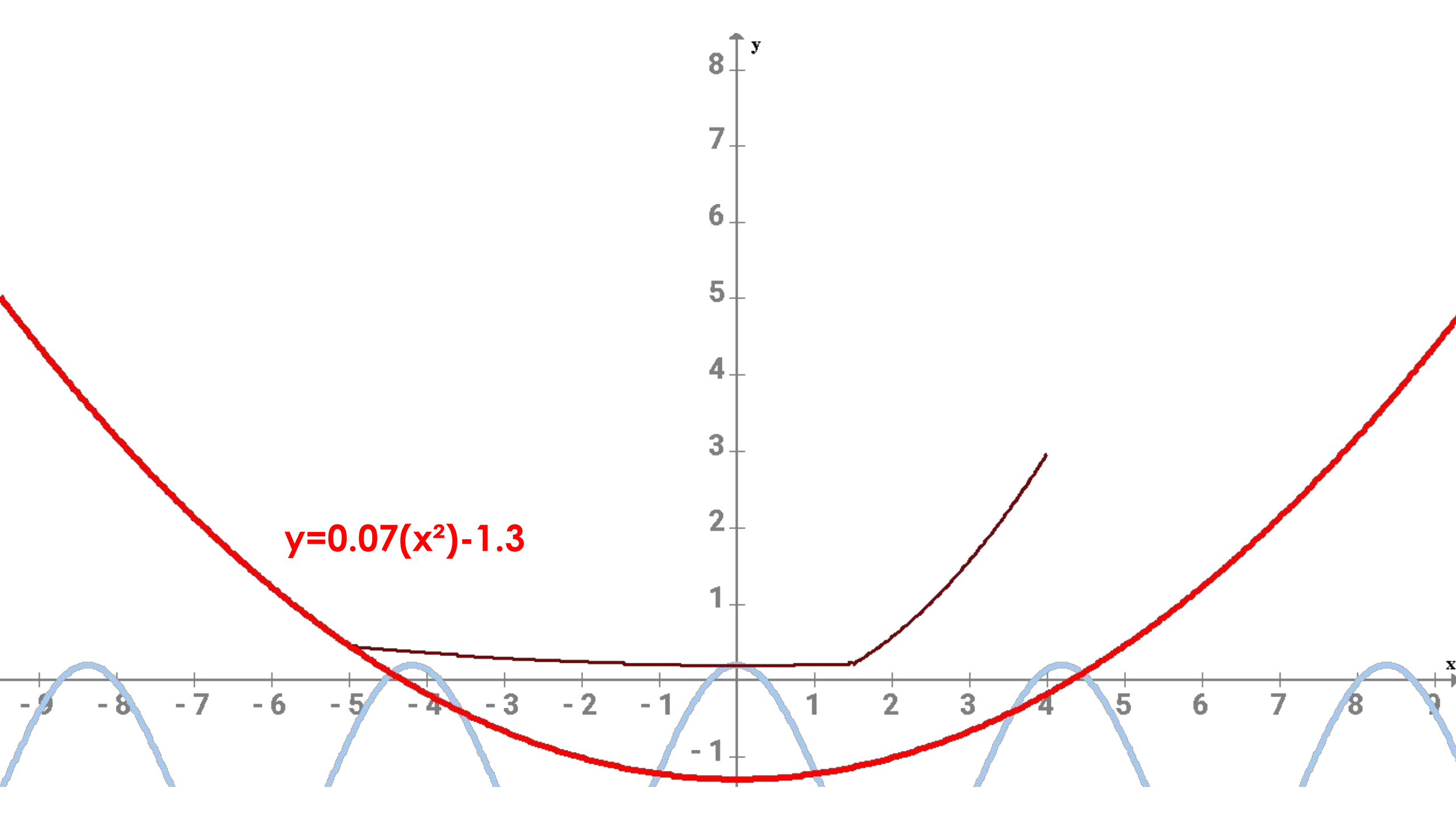

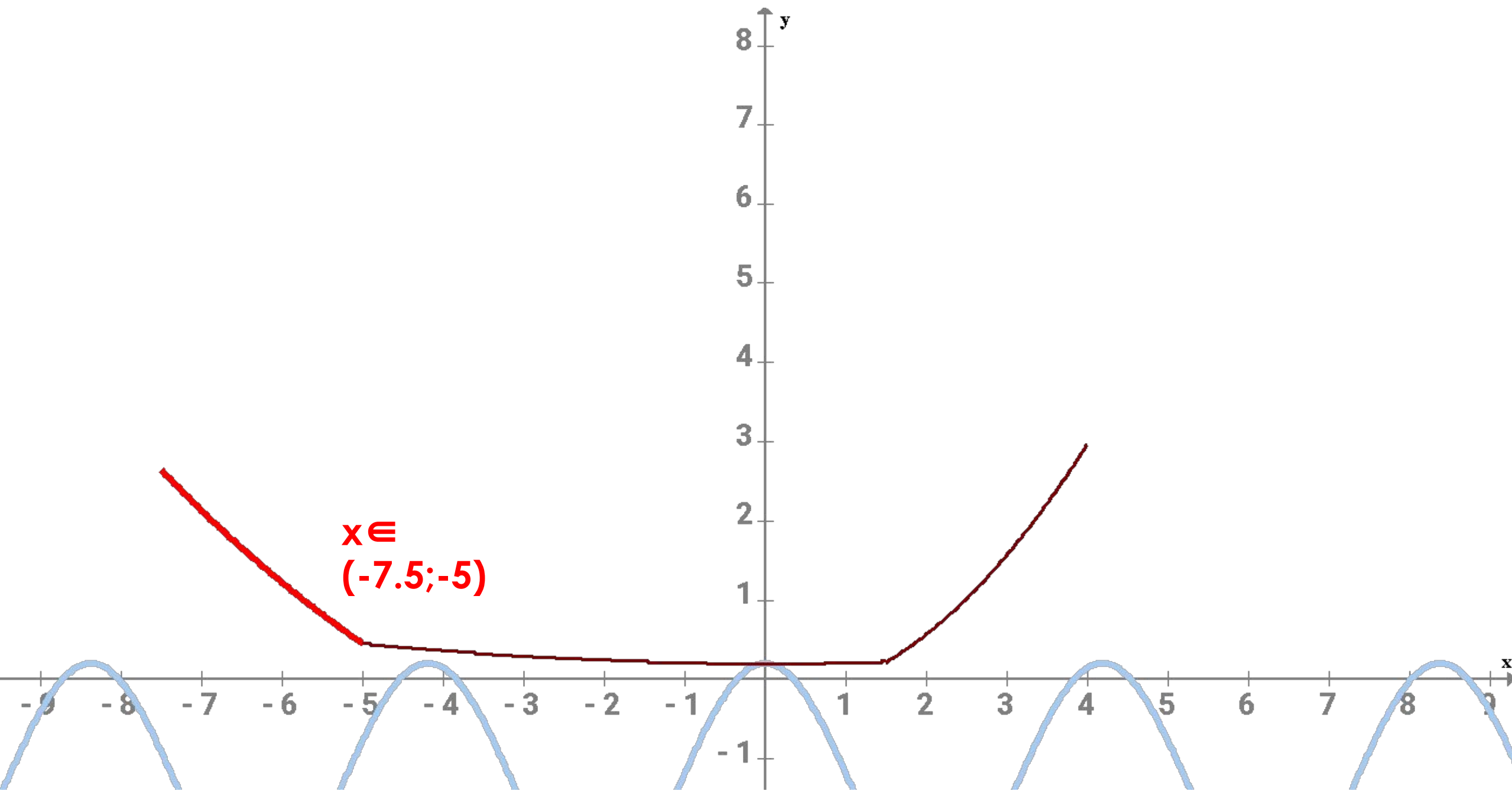

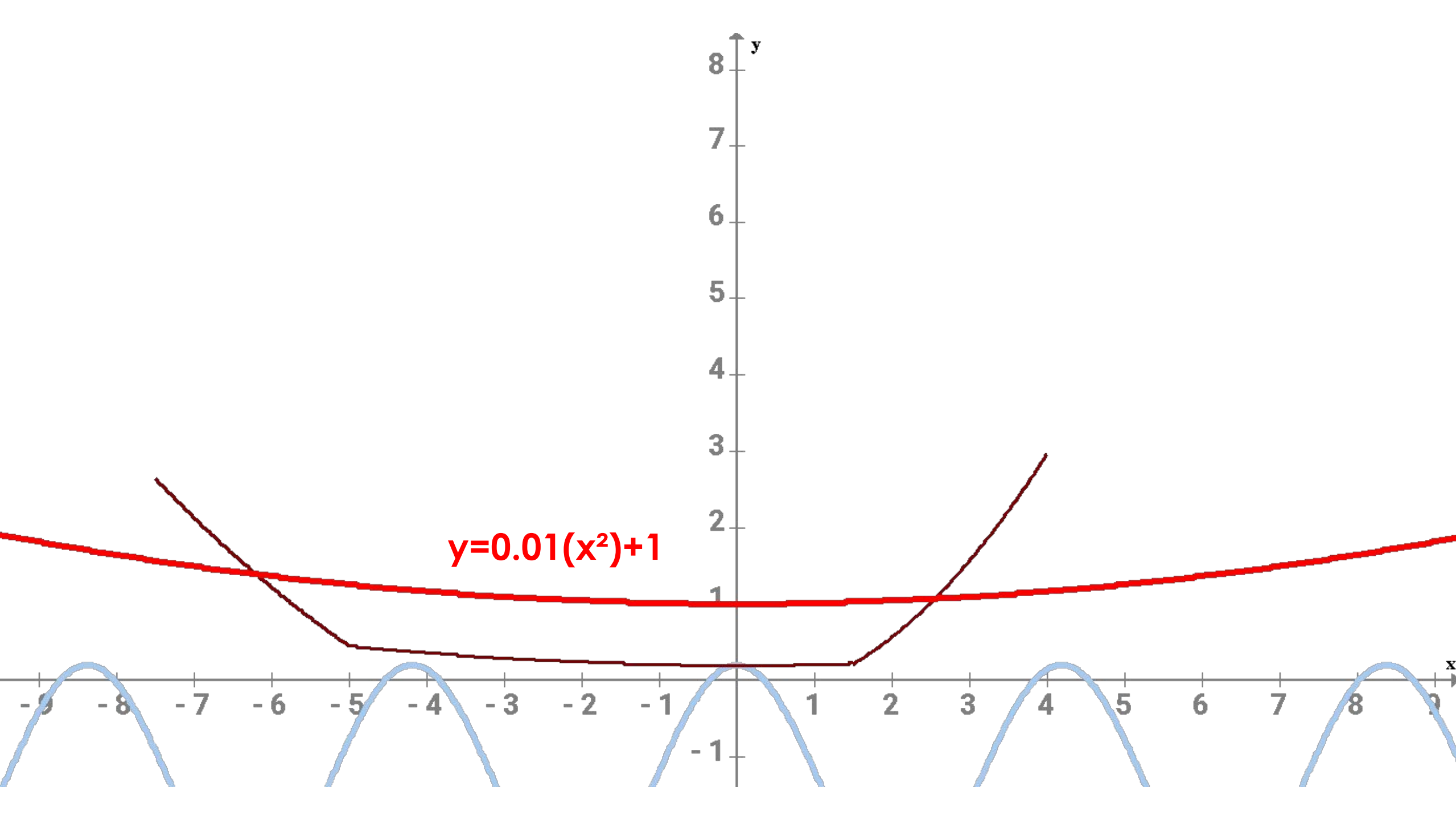

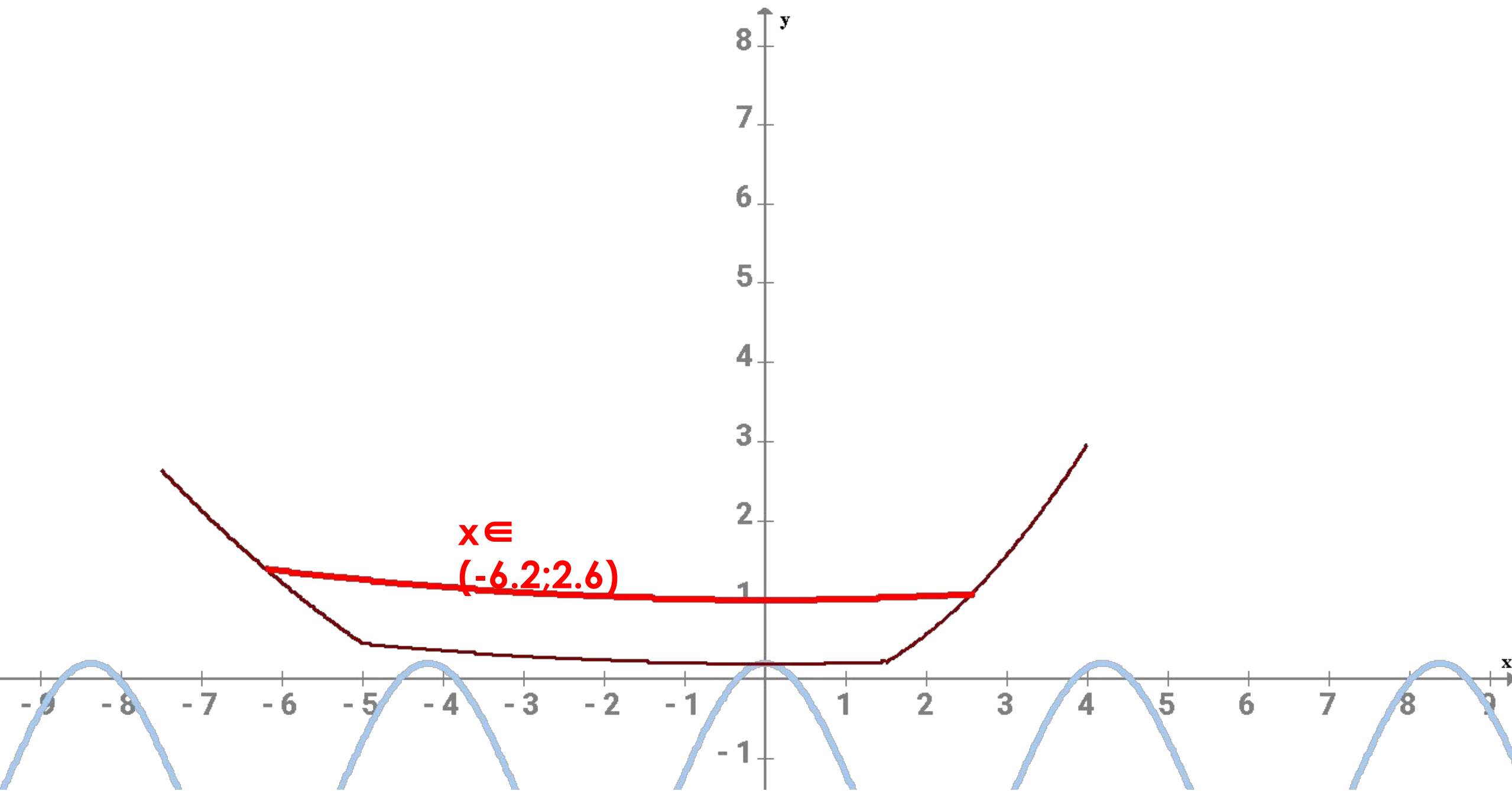

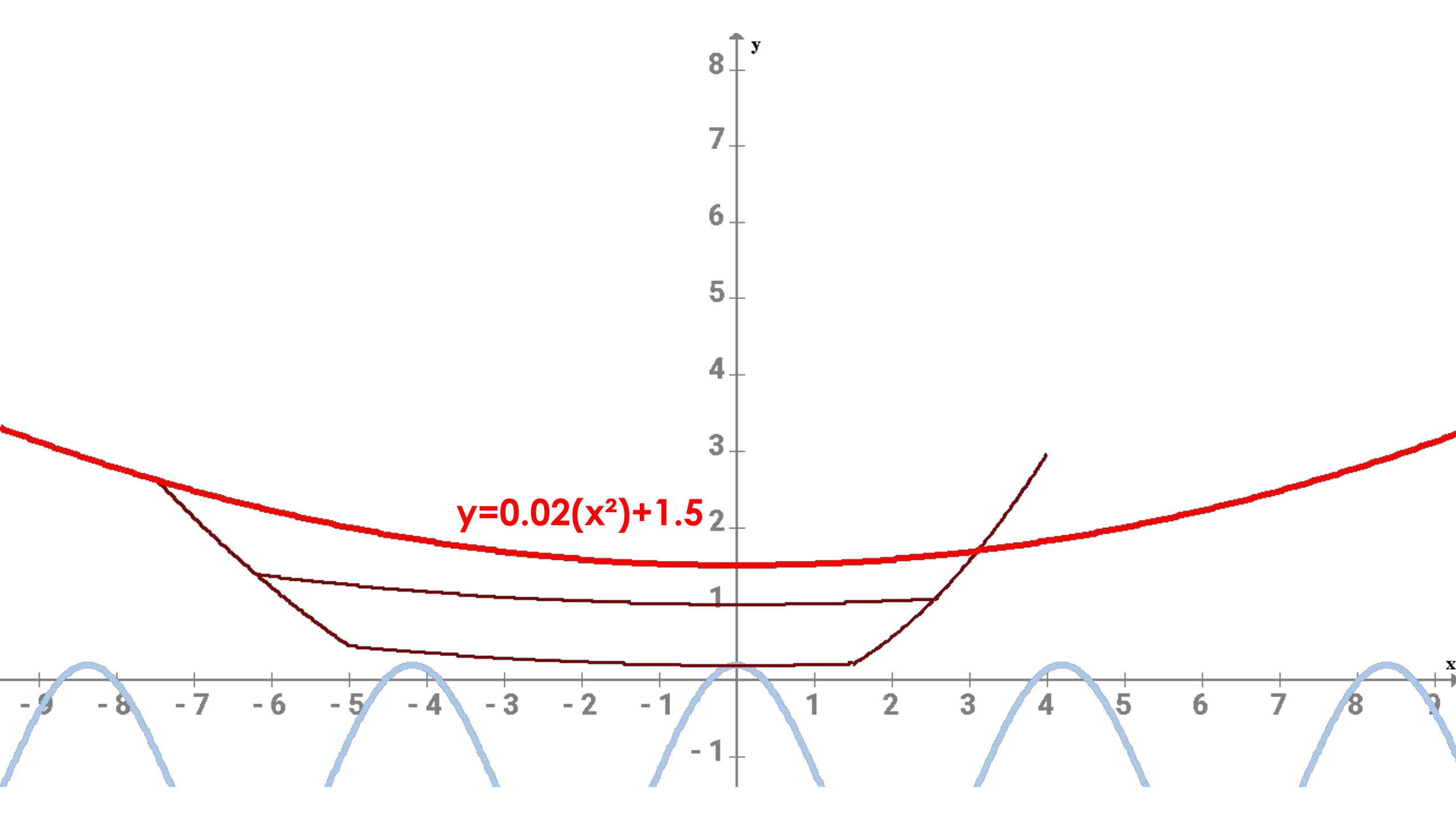

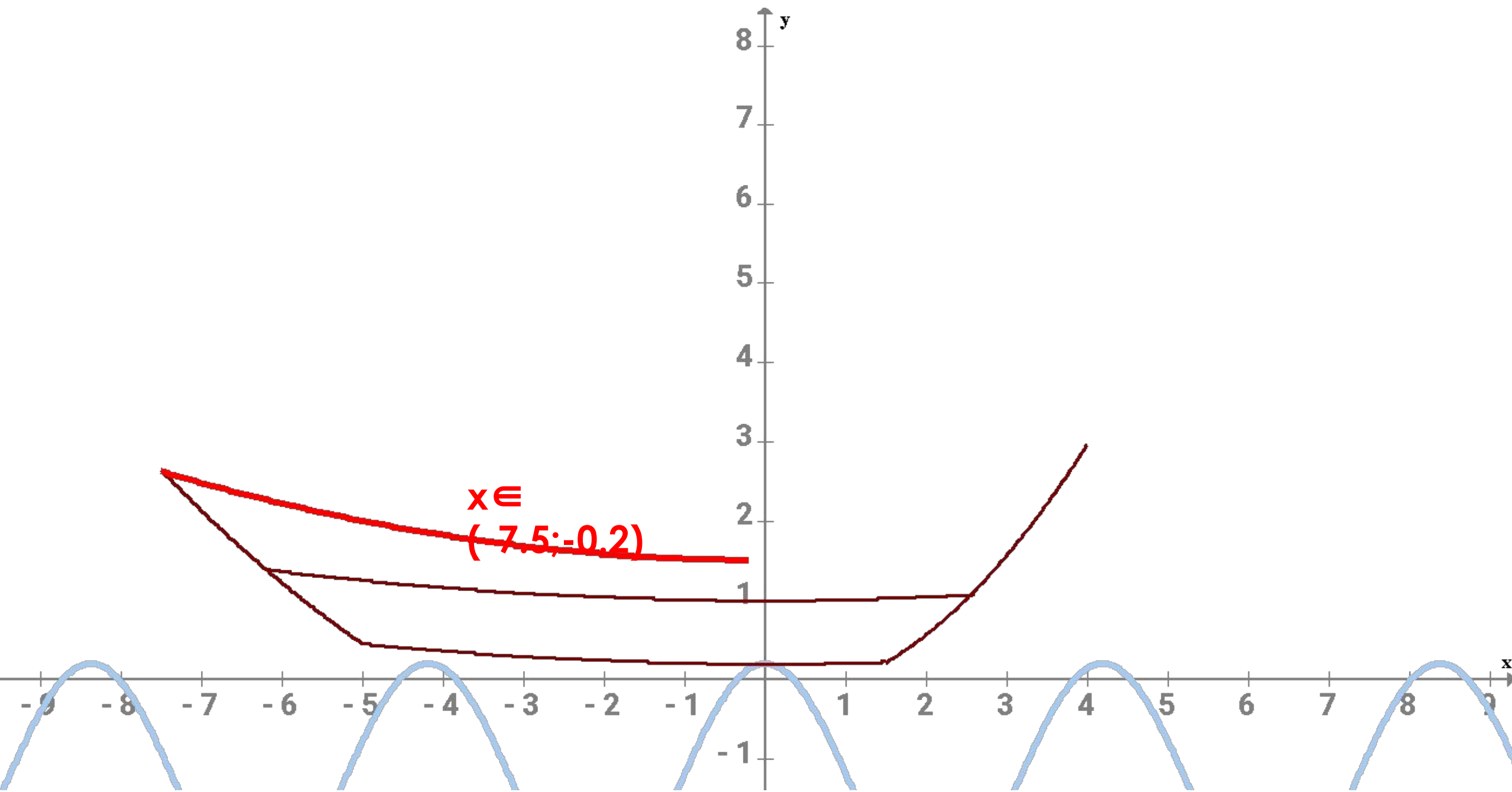

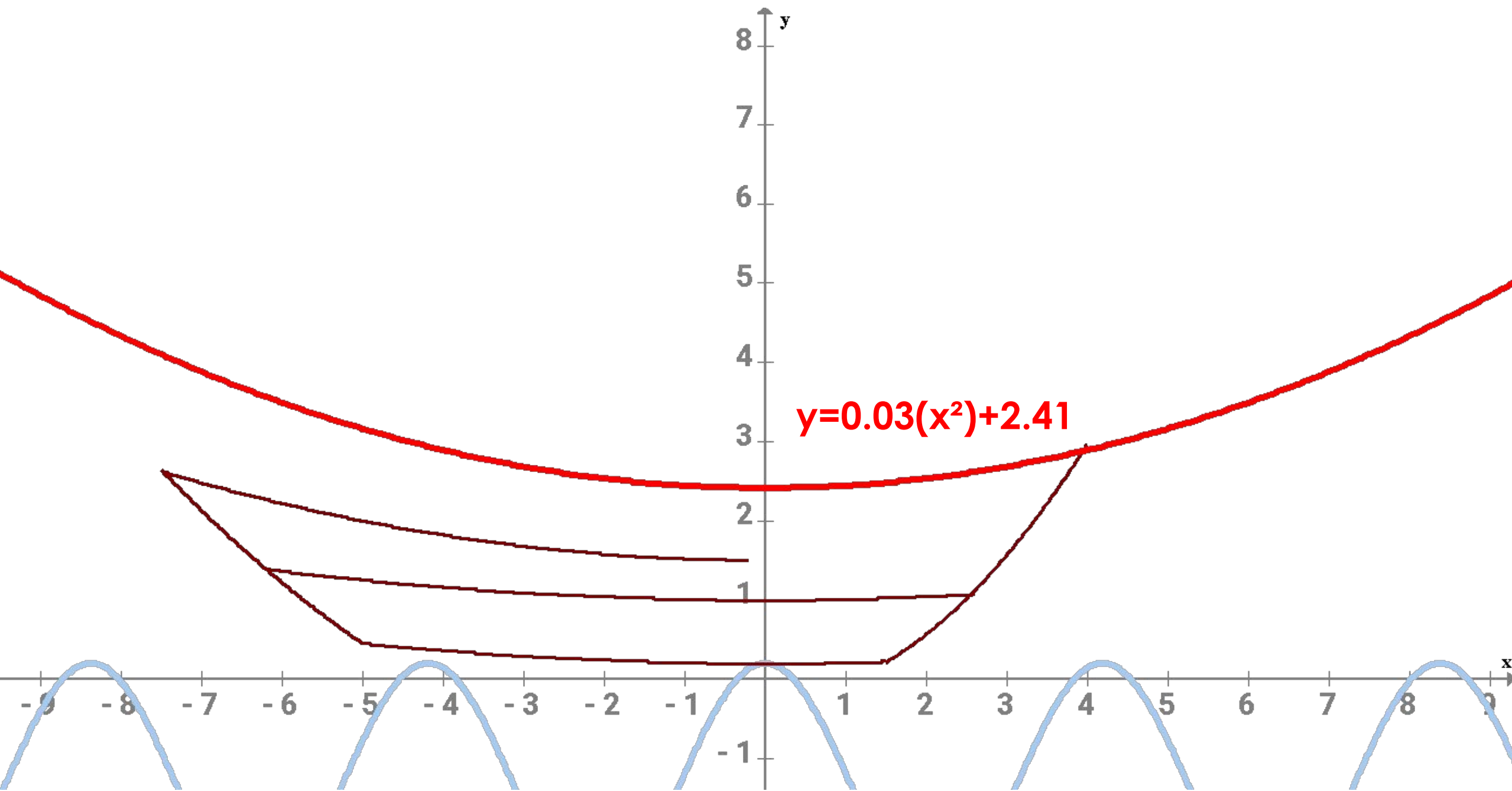

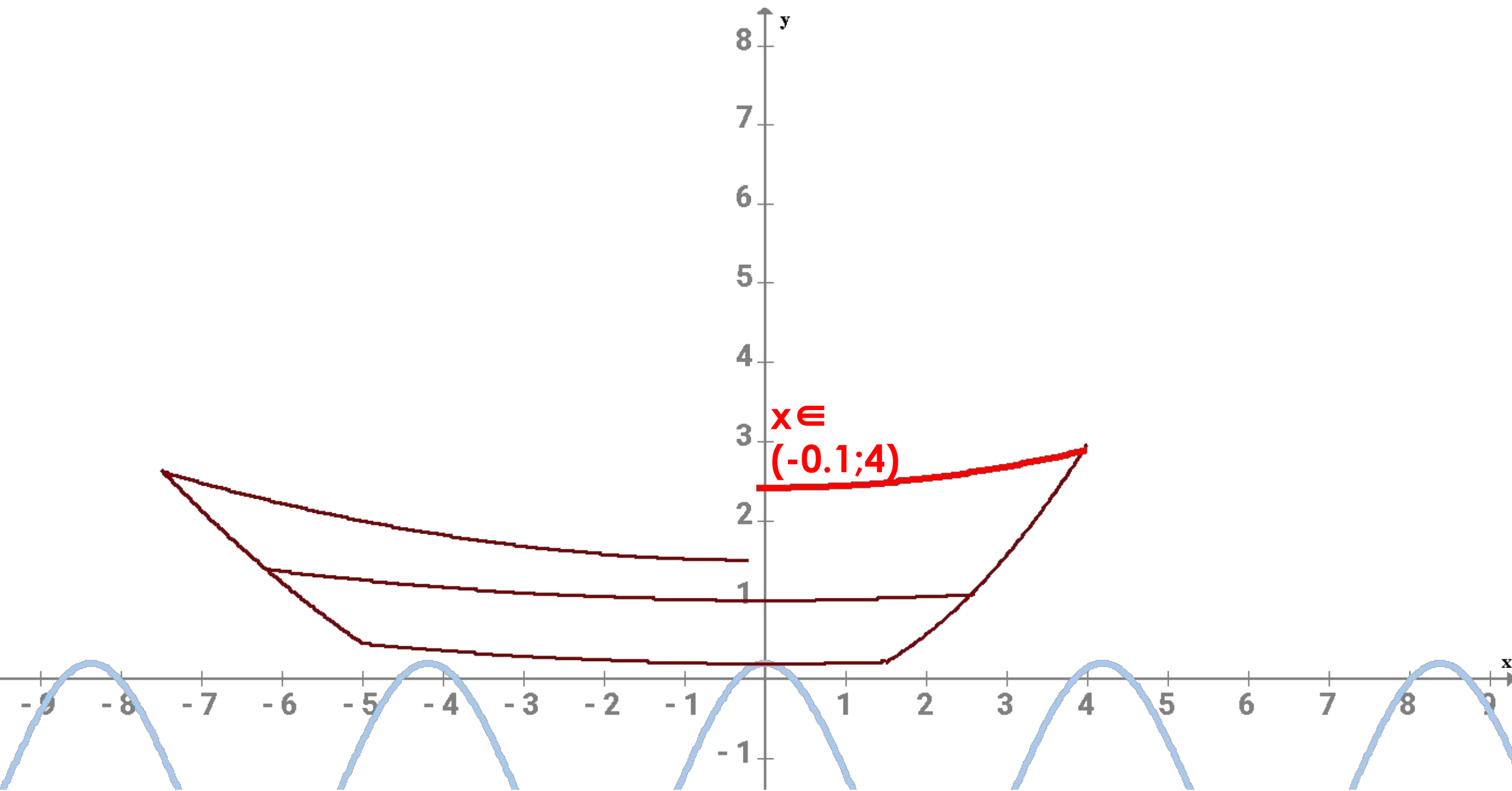

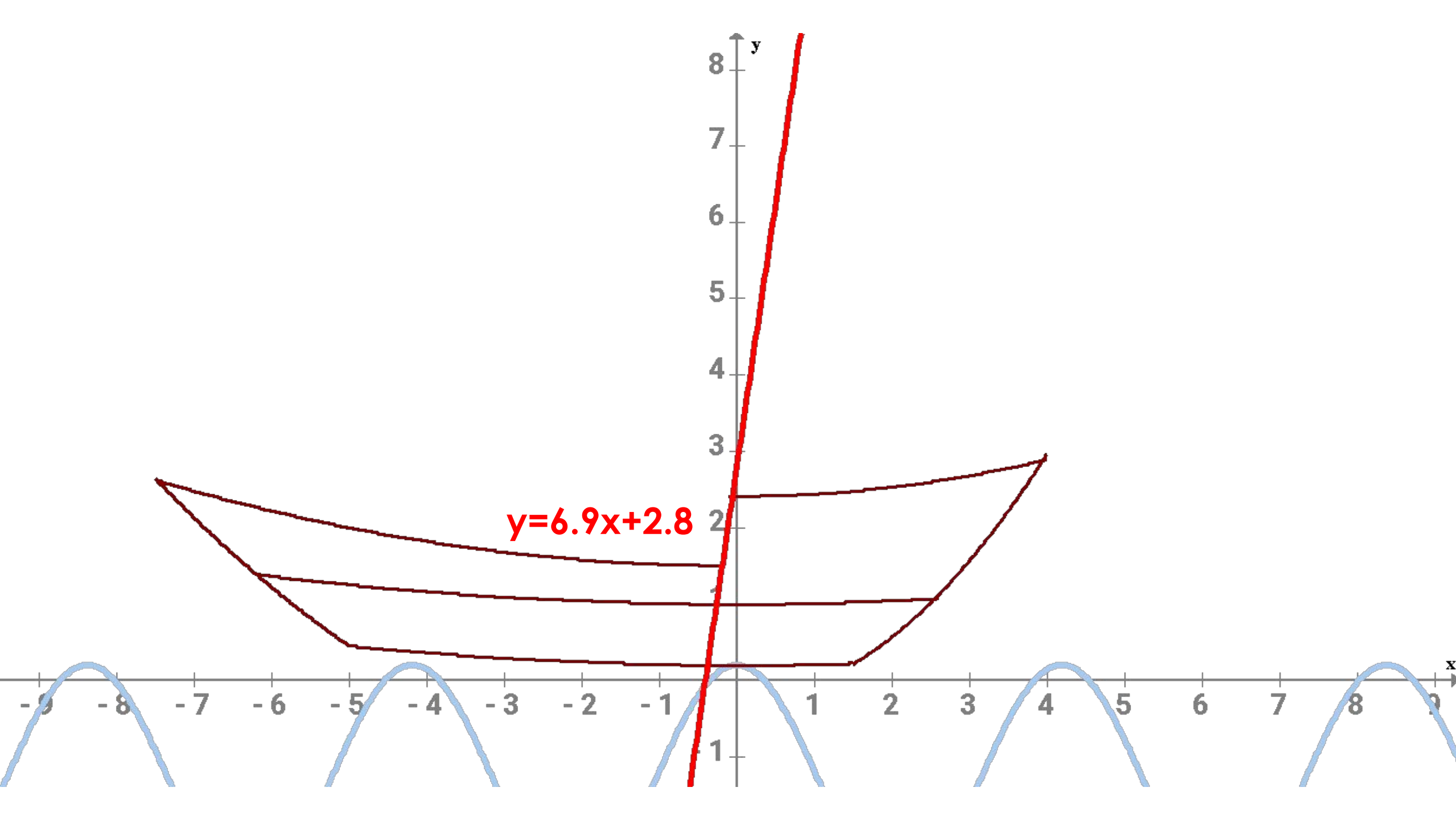

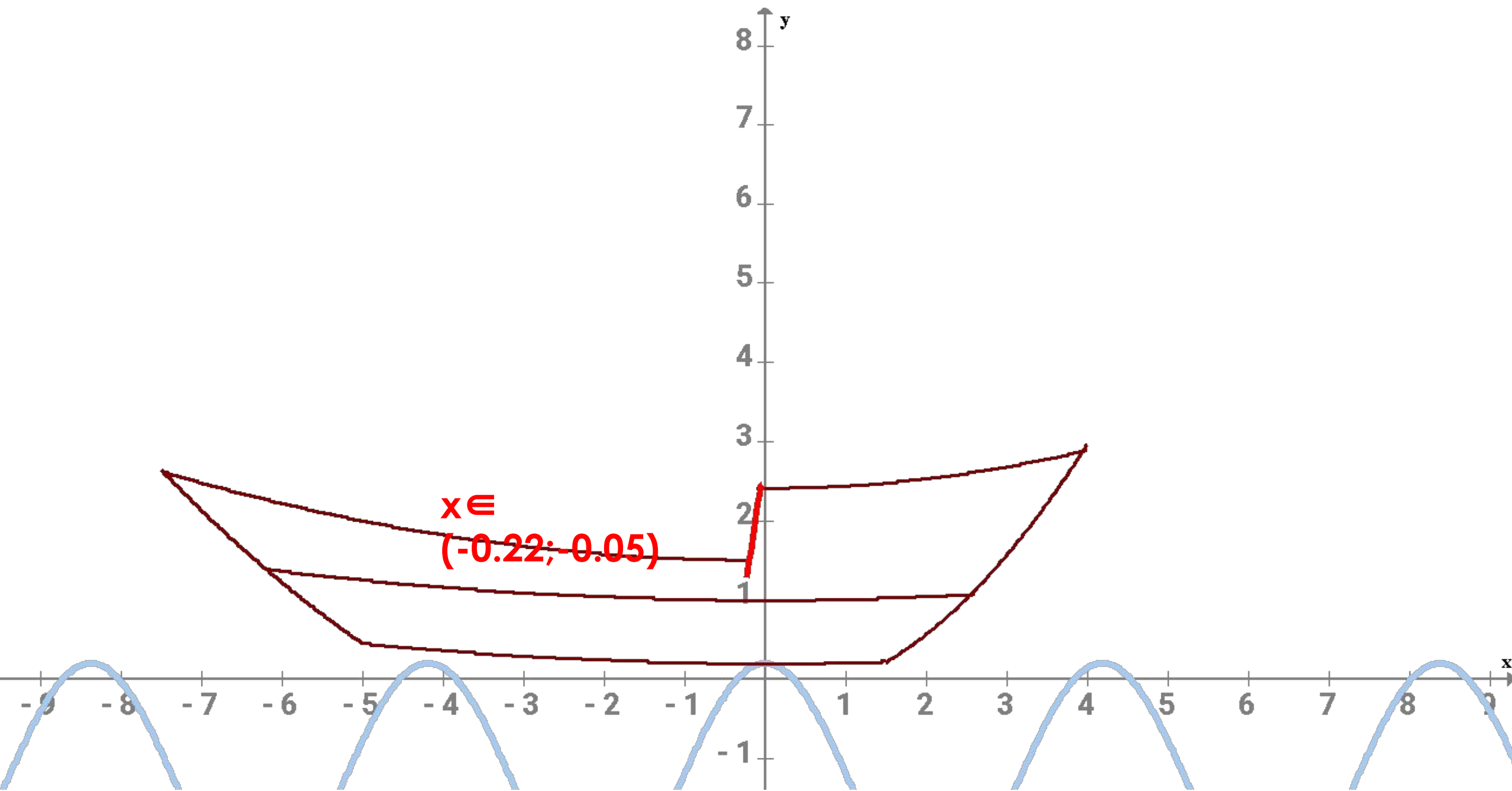

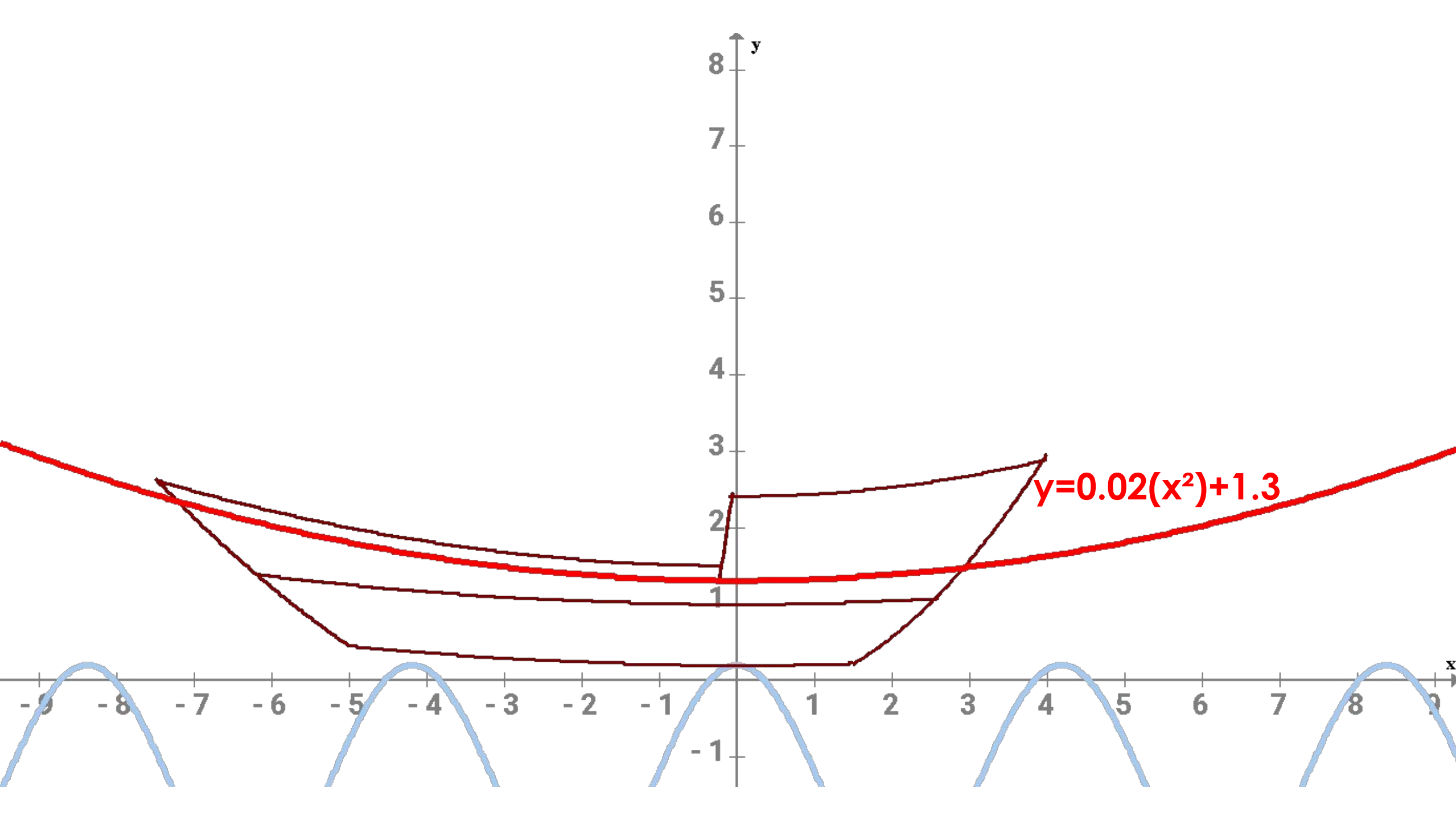

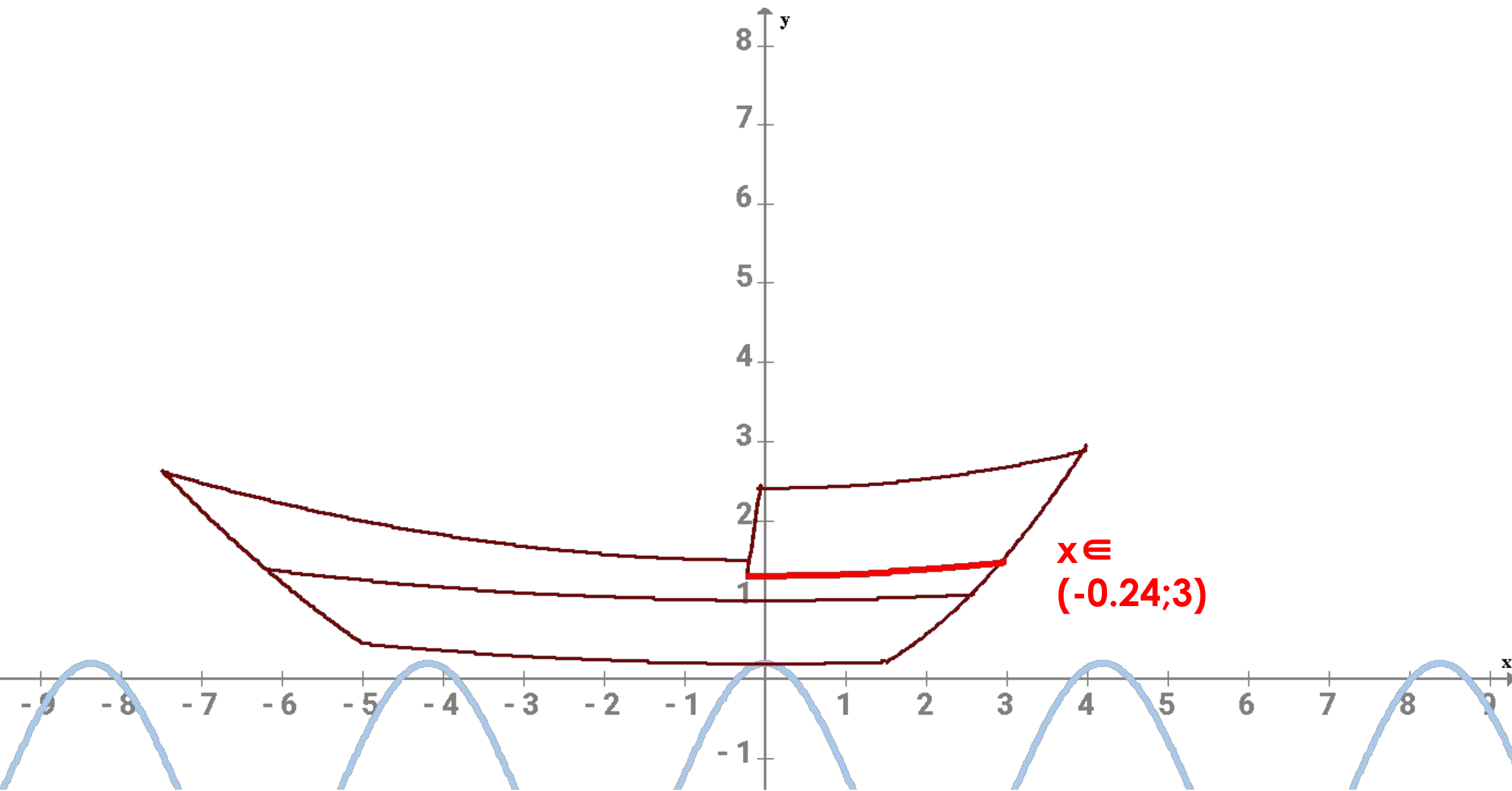

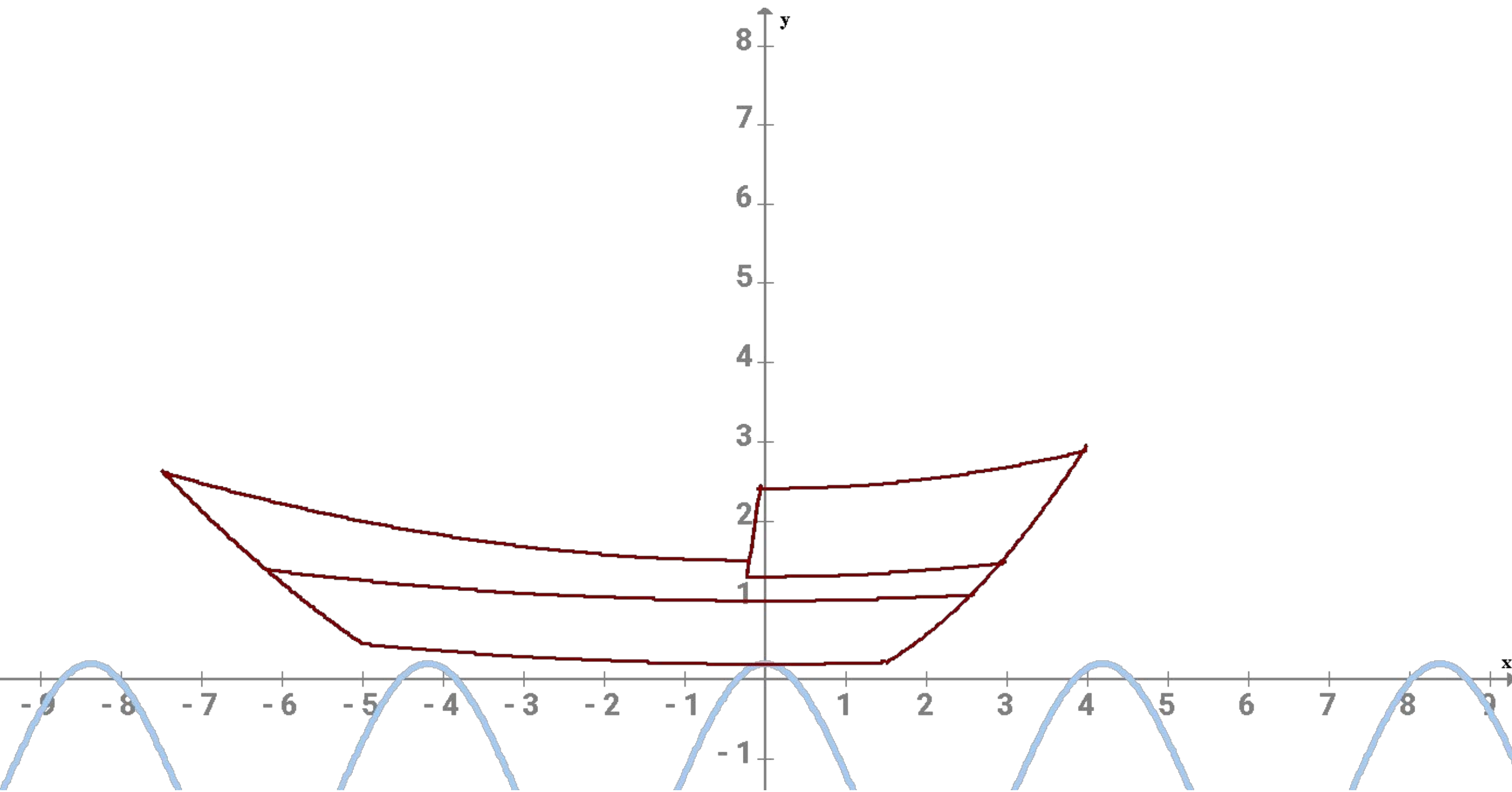

III этап

- «Мачты»

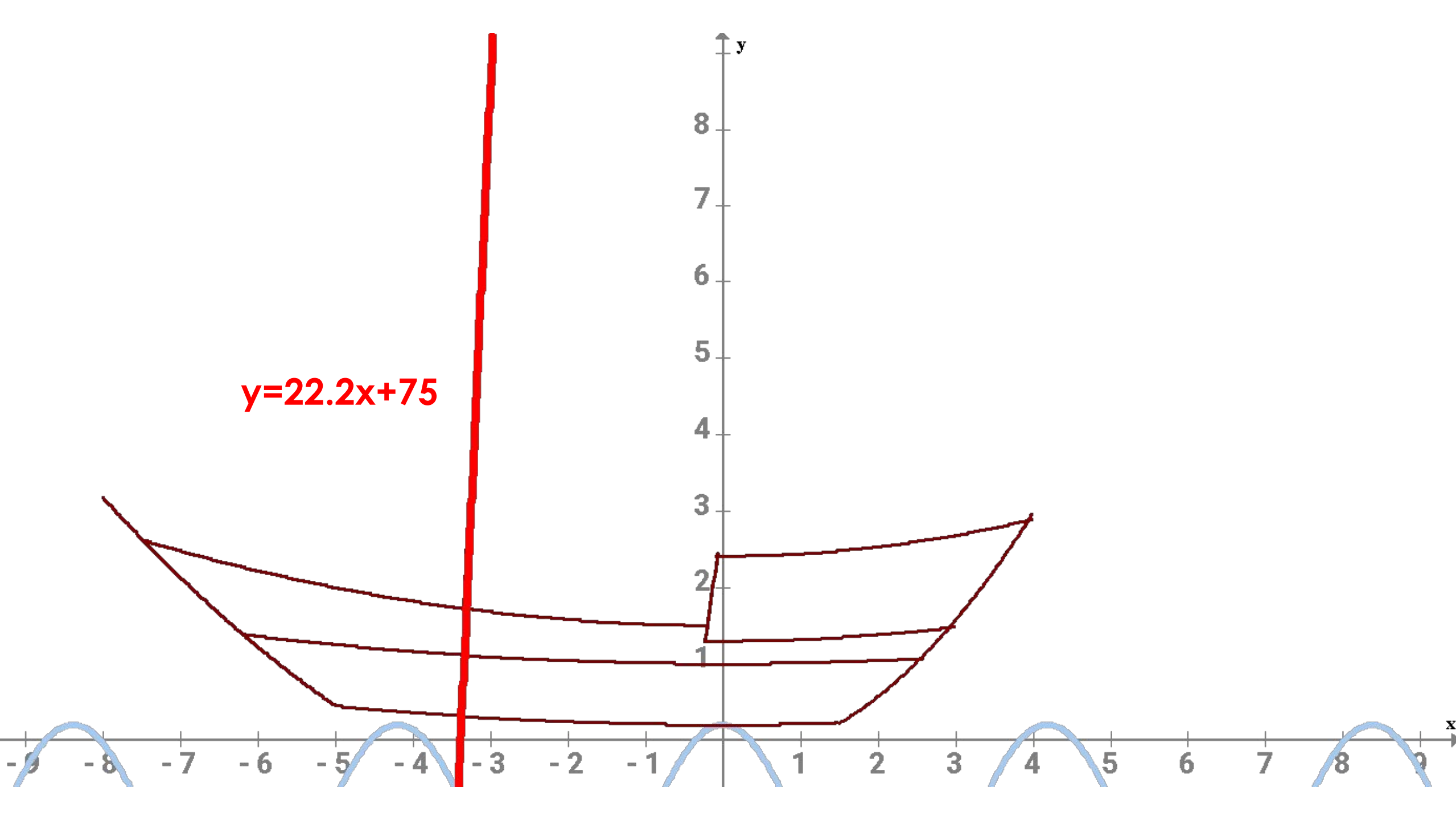

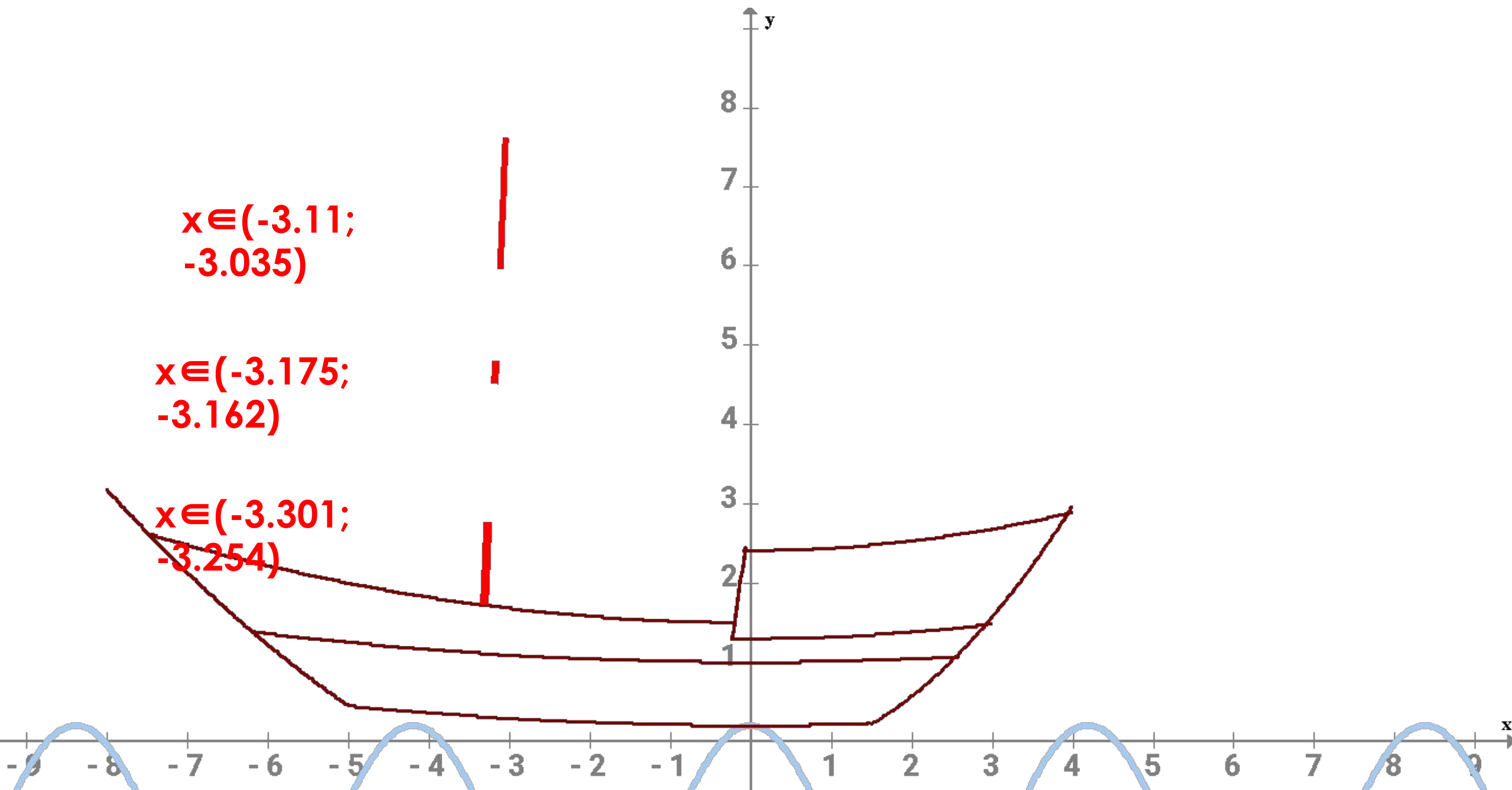

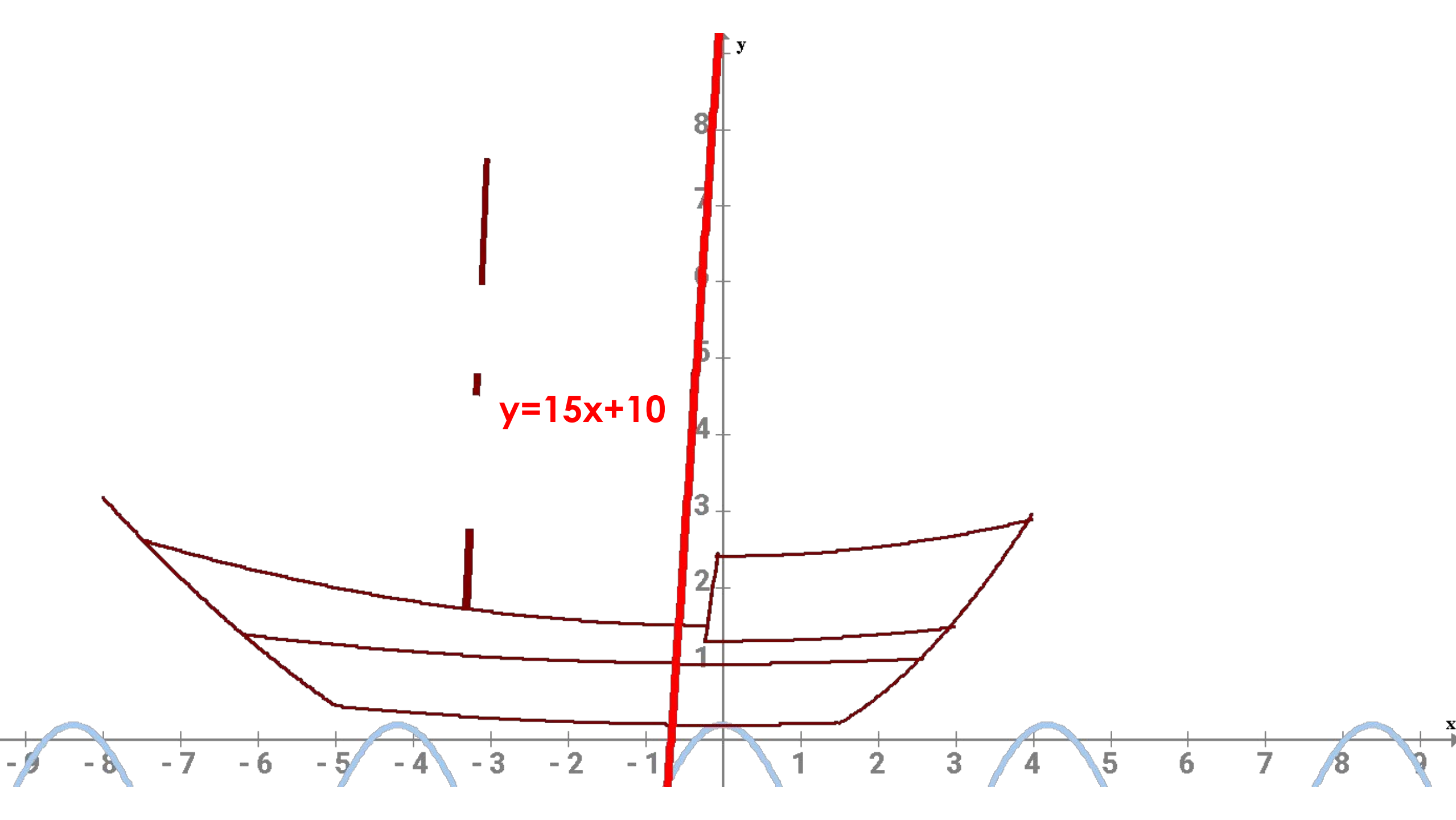

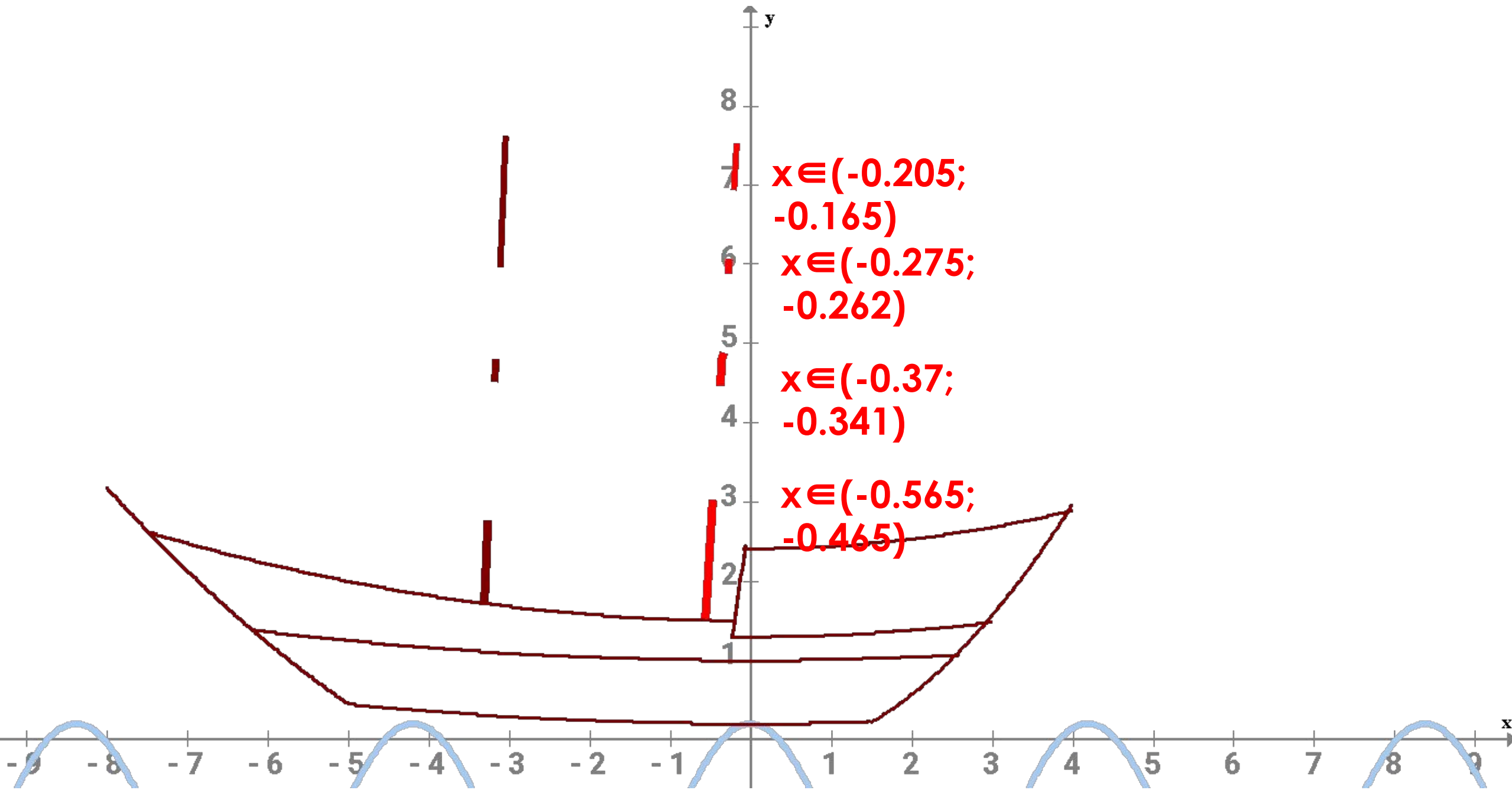

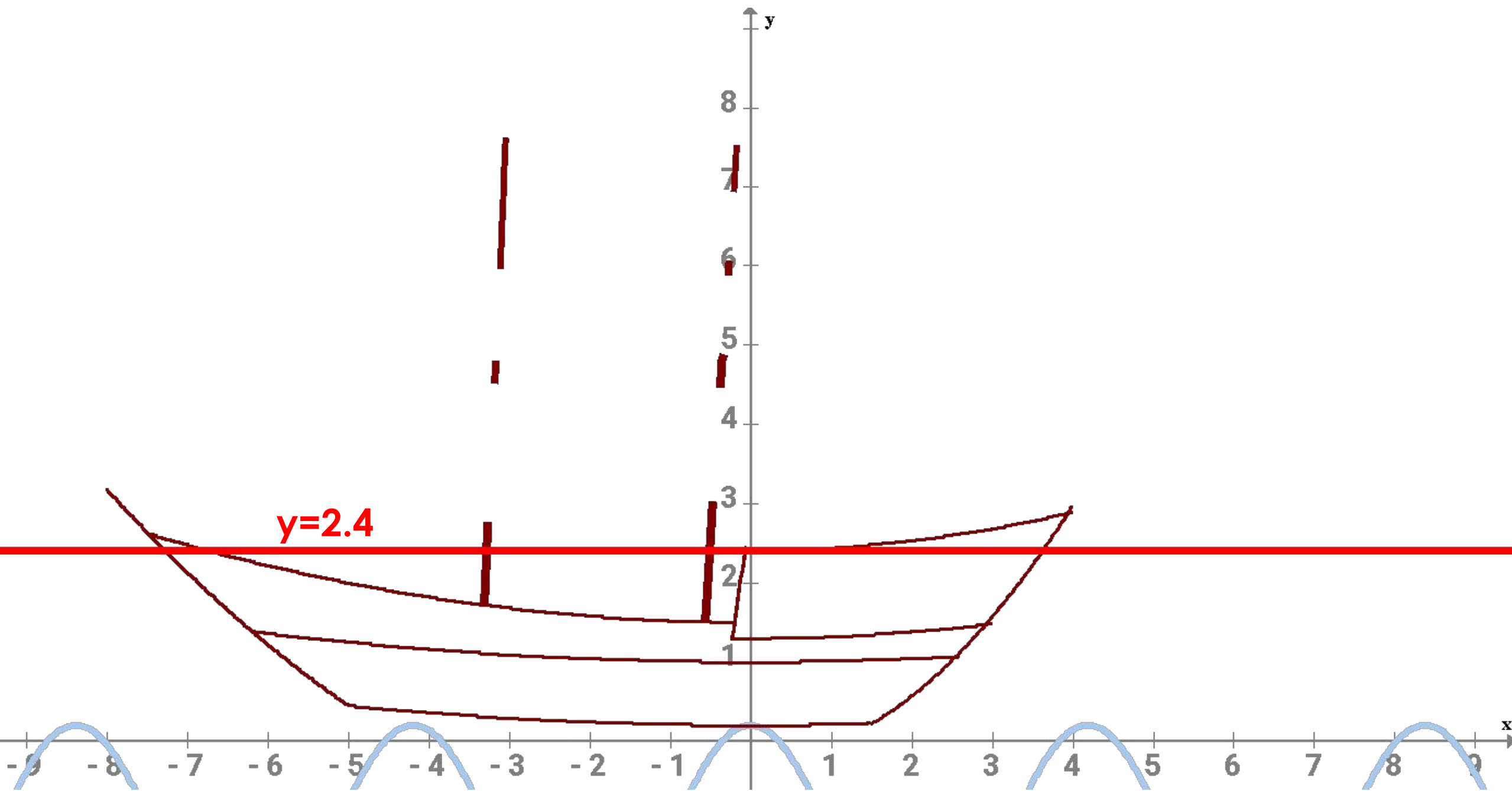

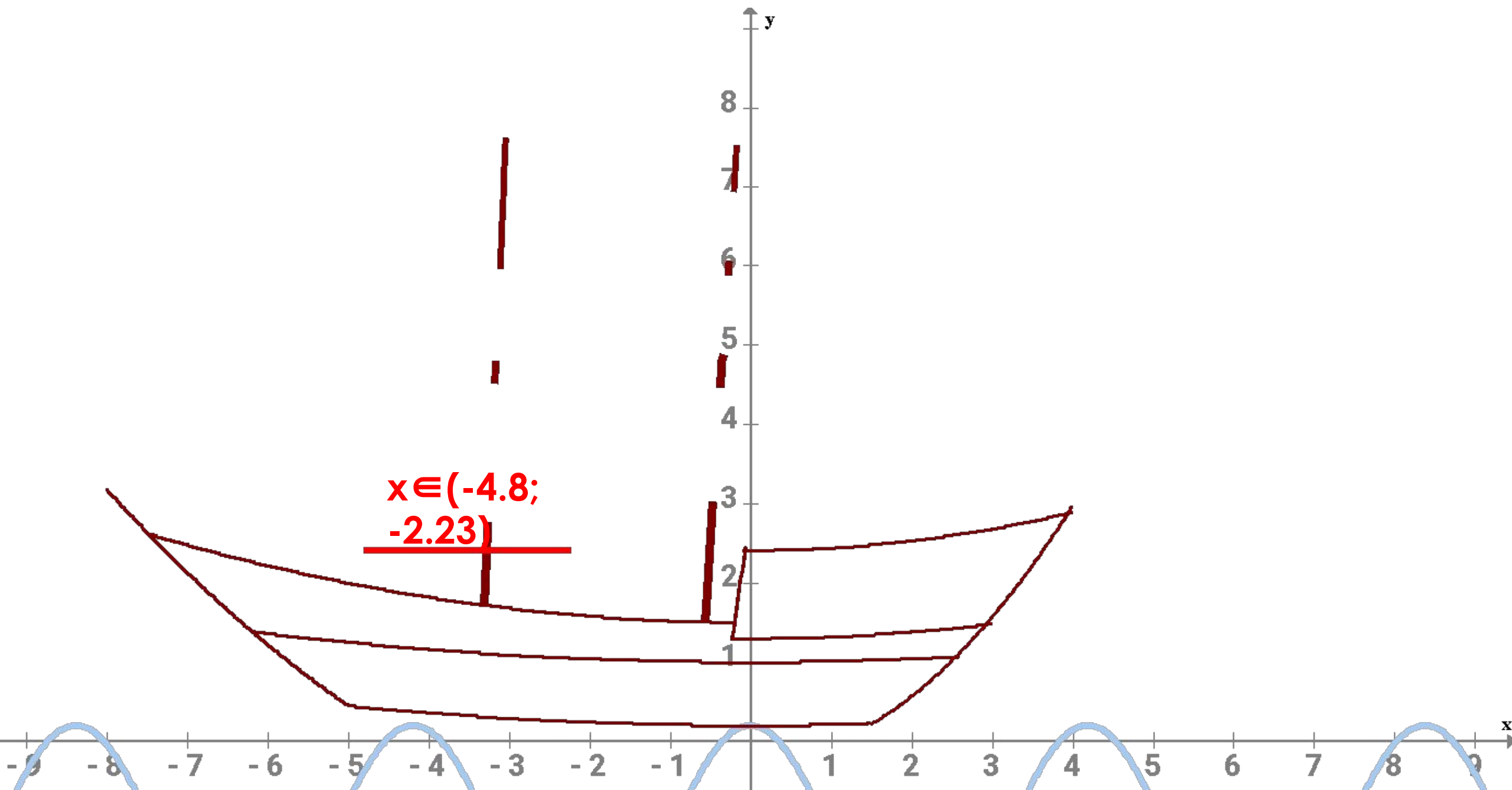

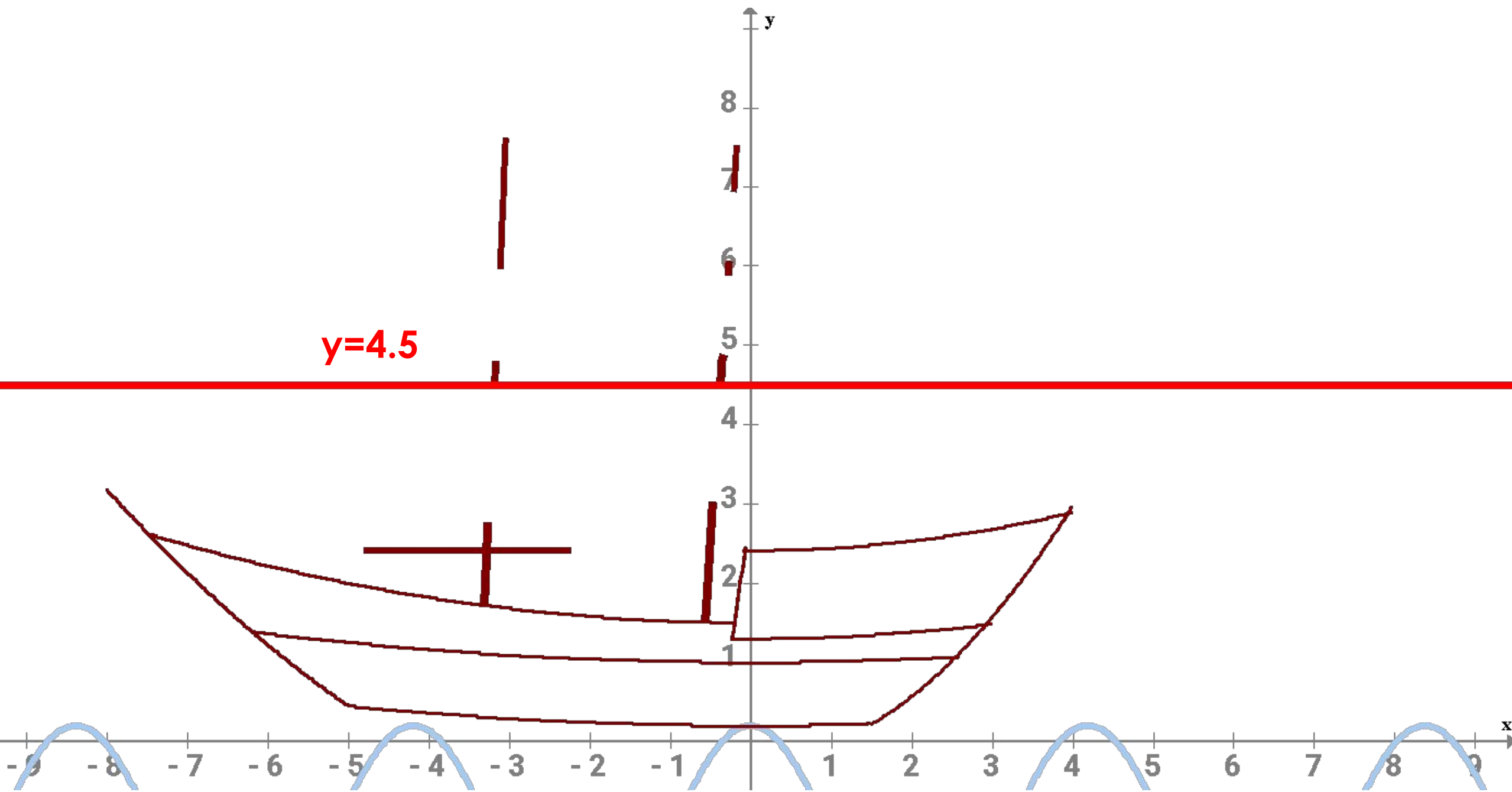

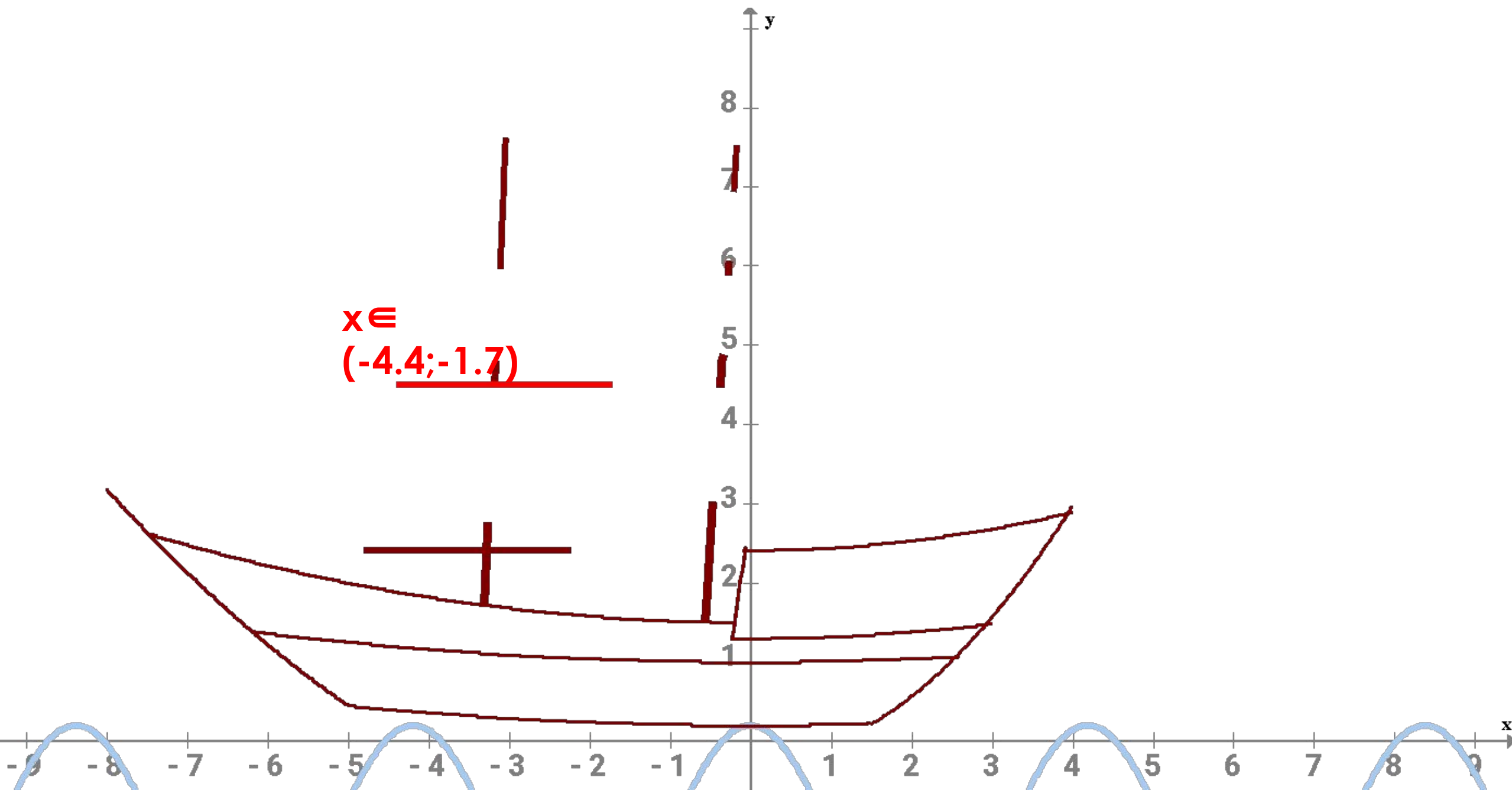

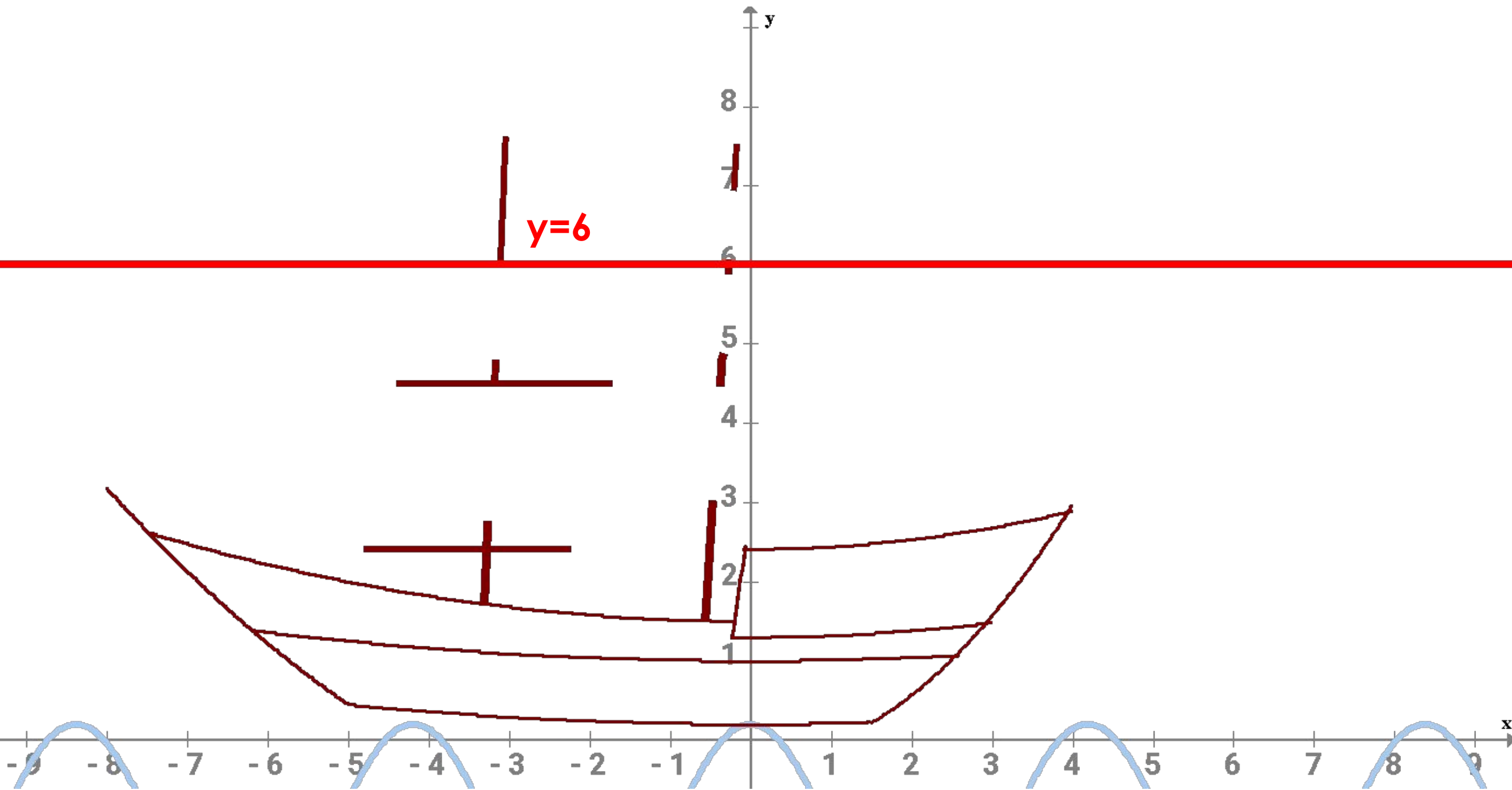

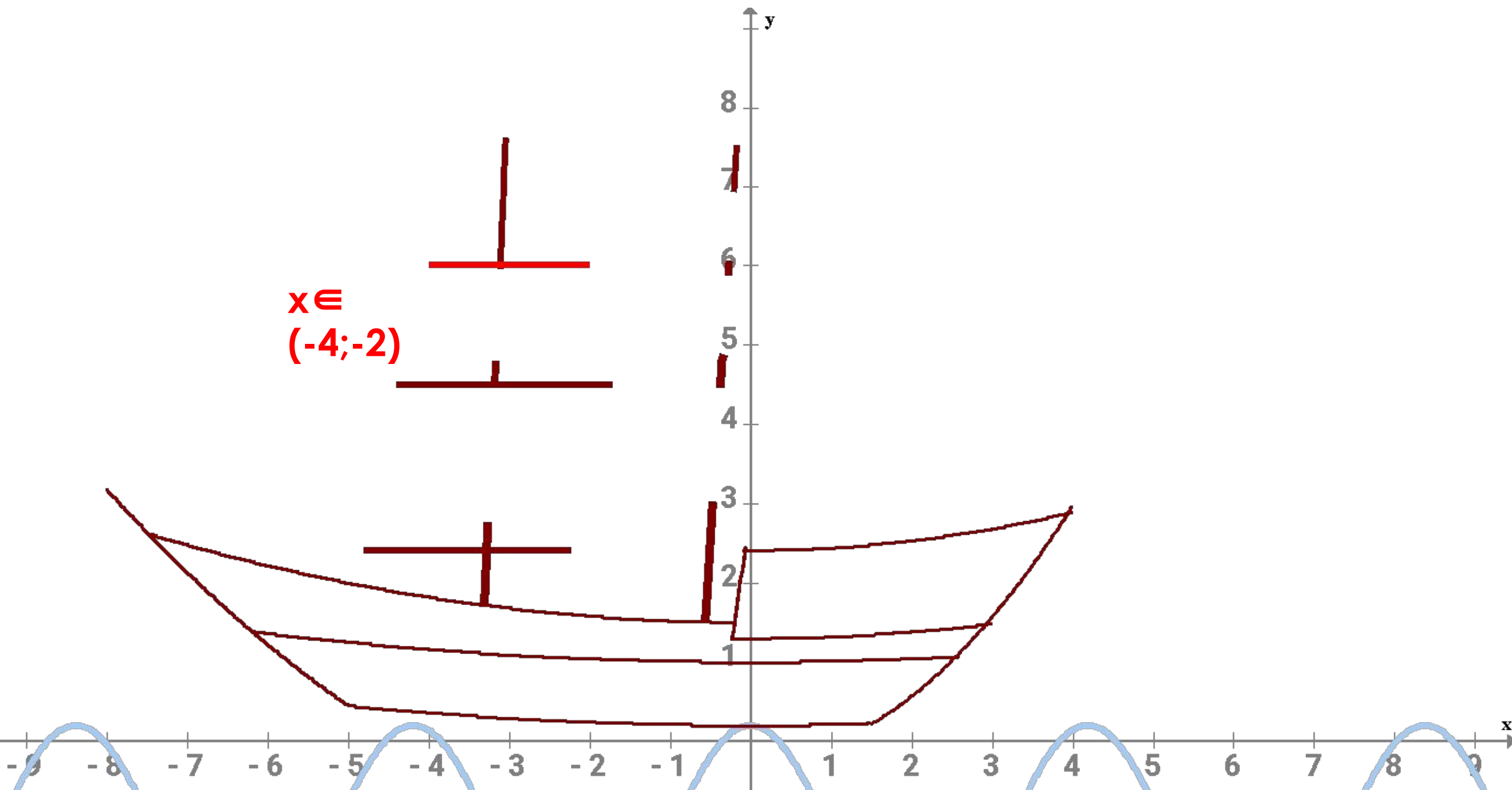

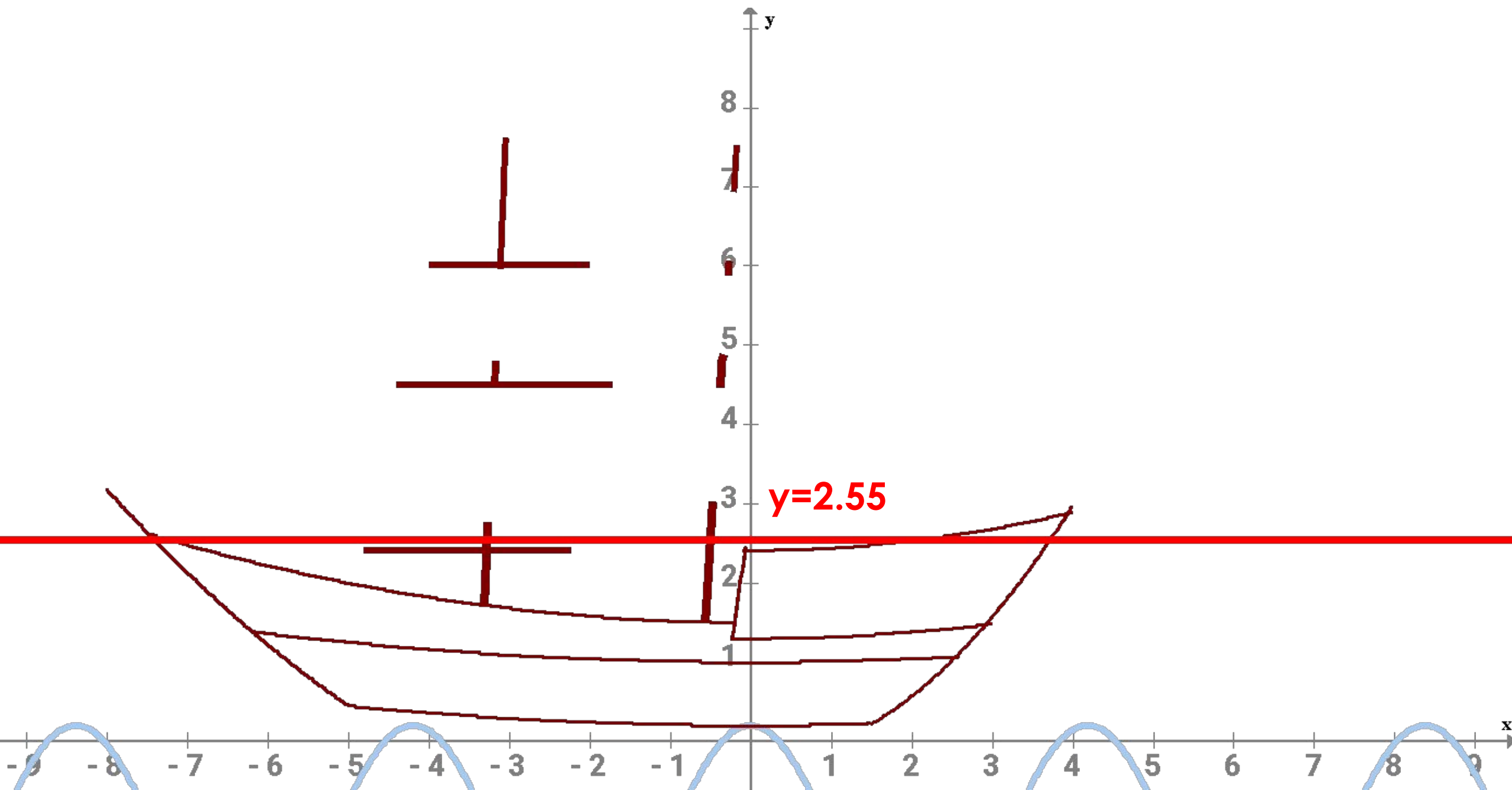

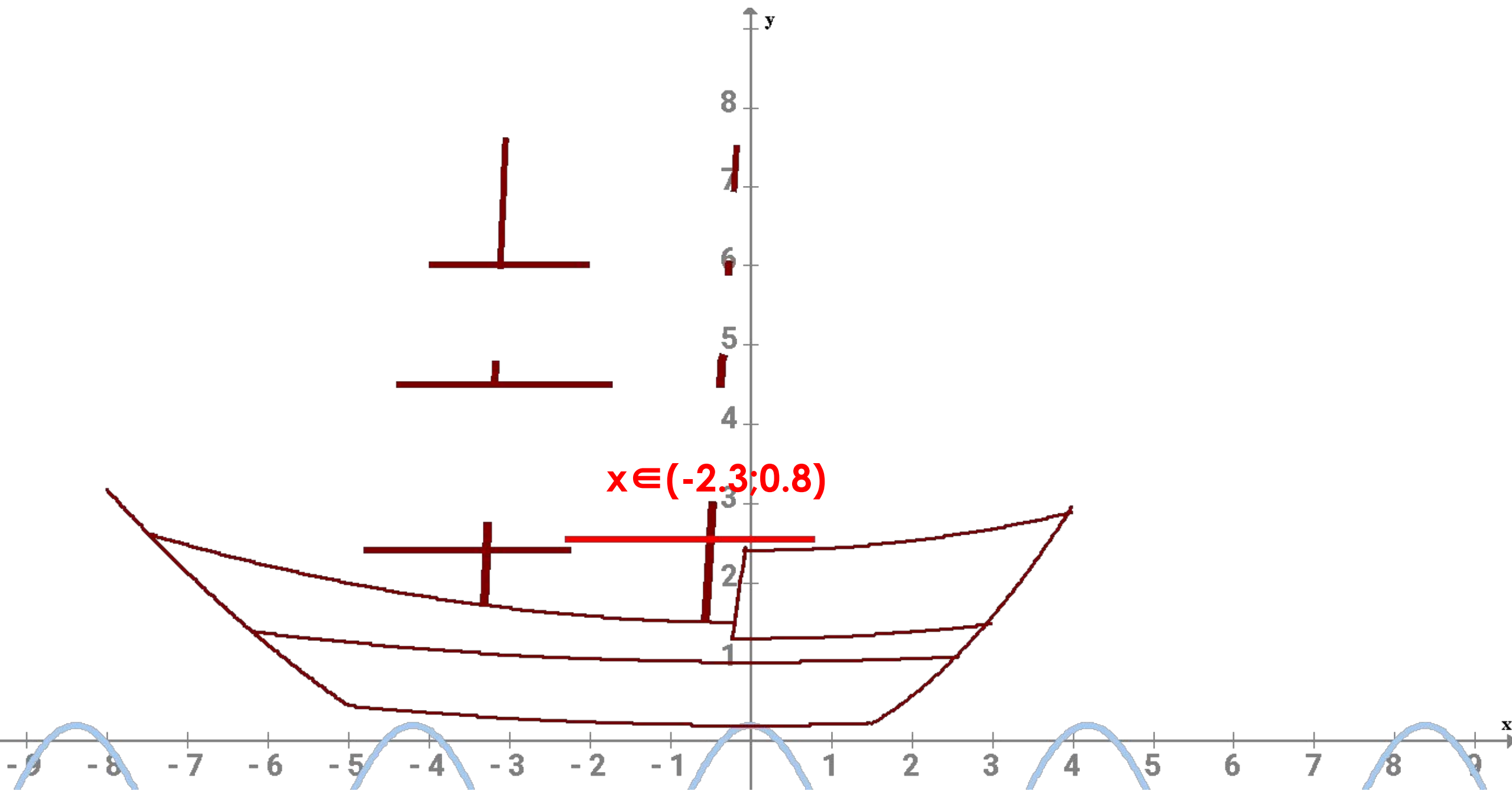

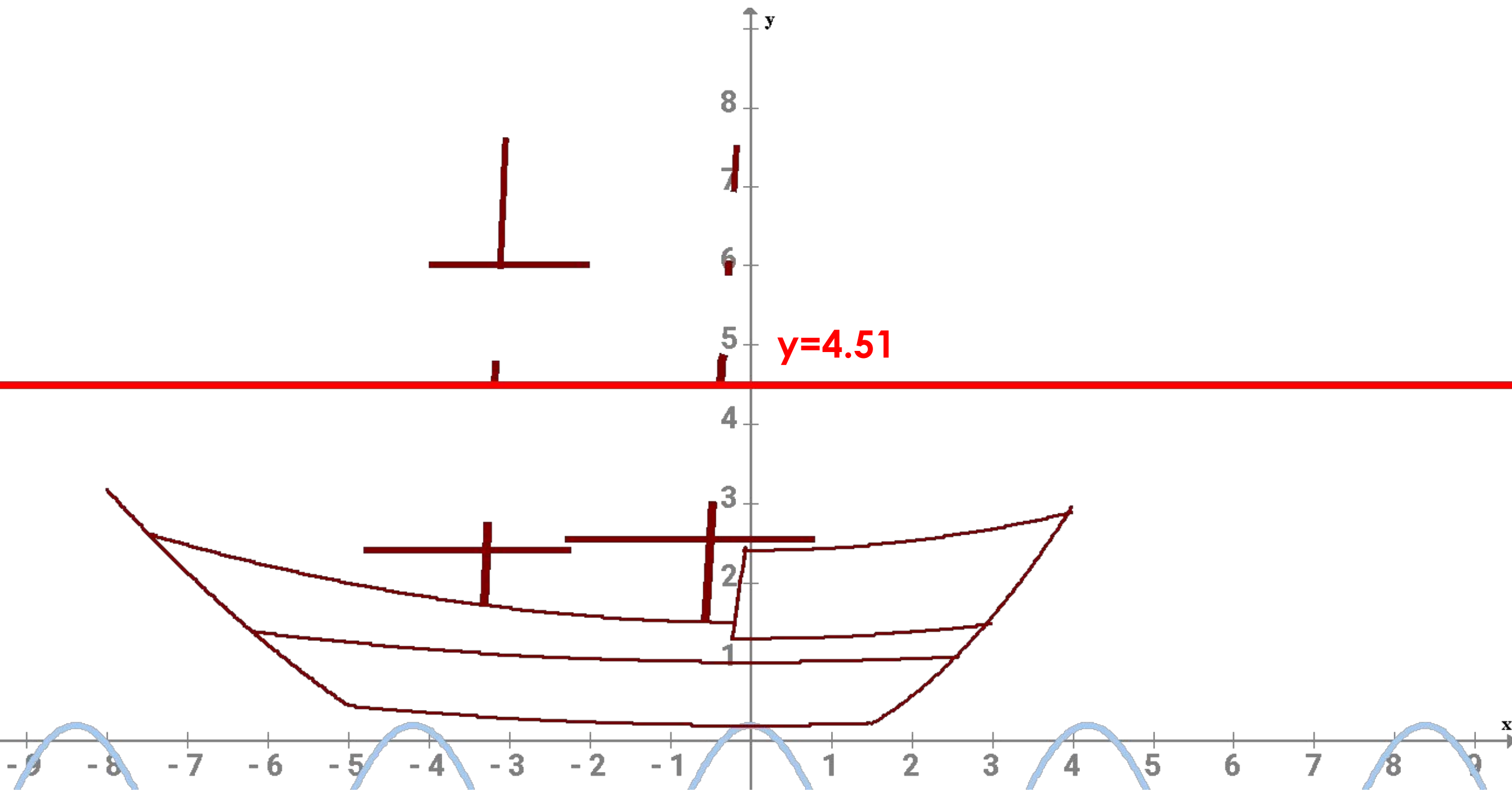

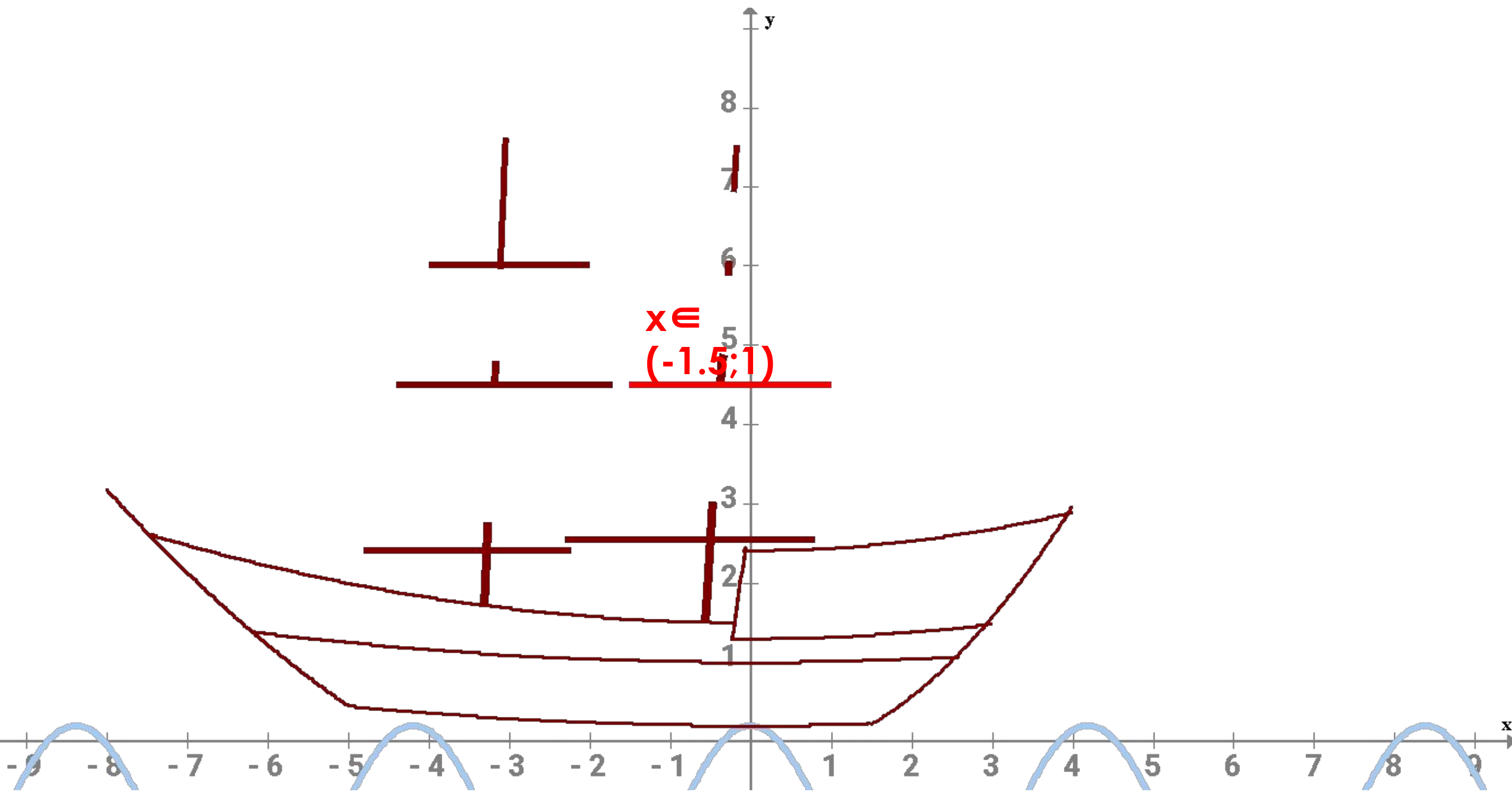

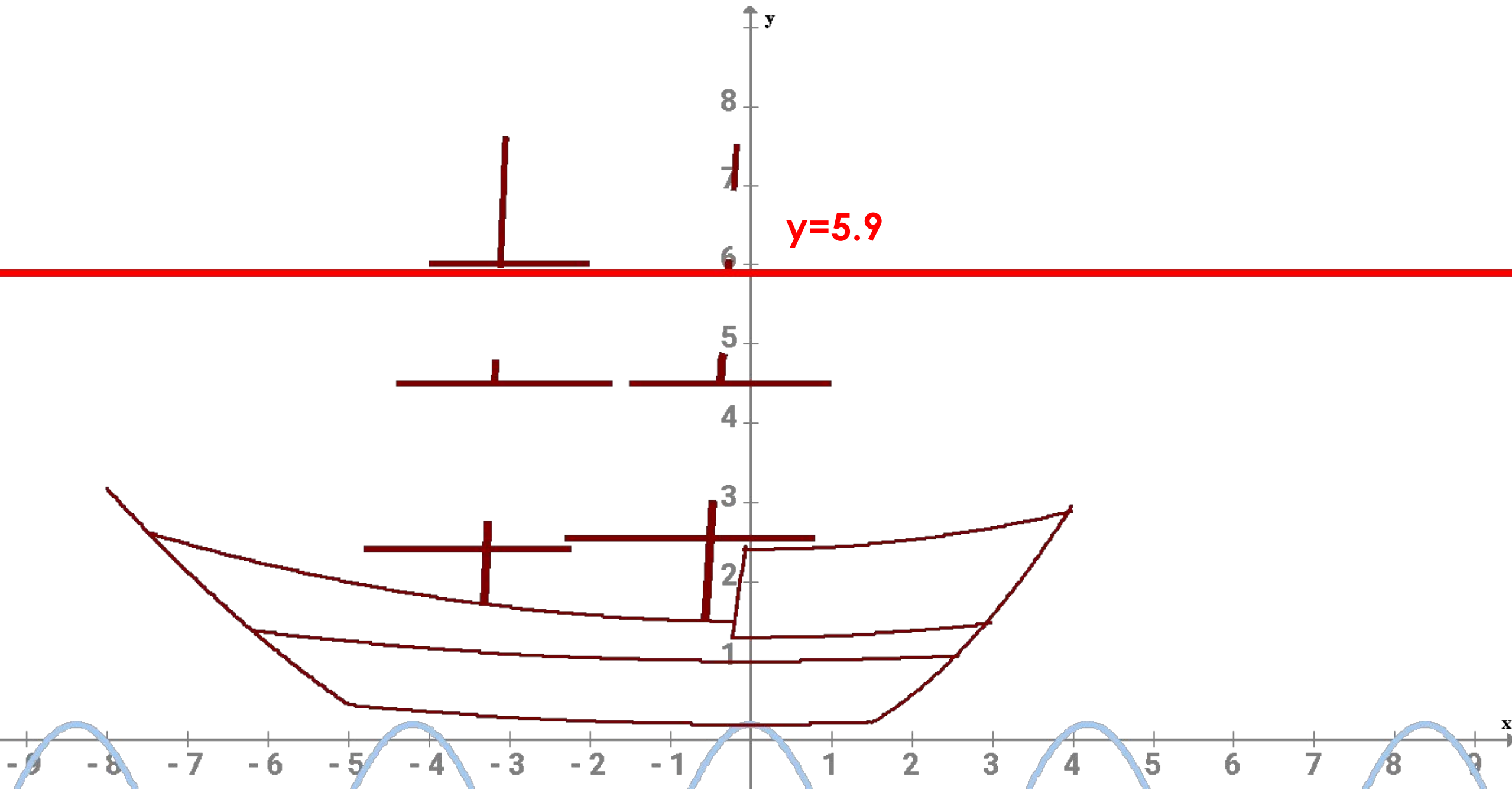

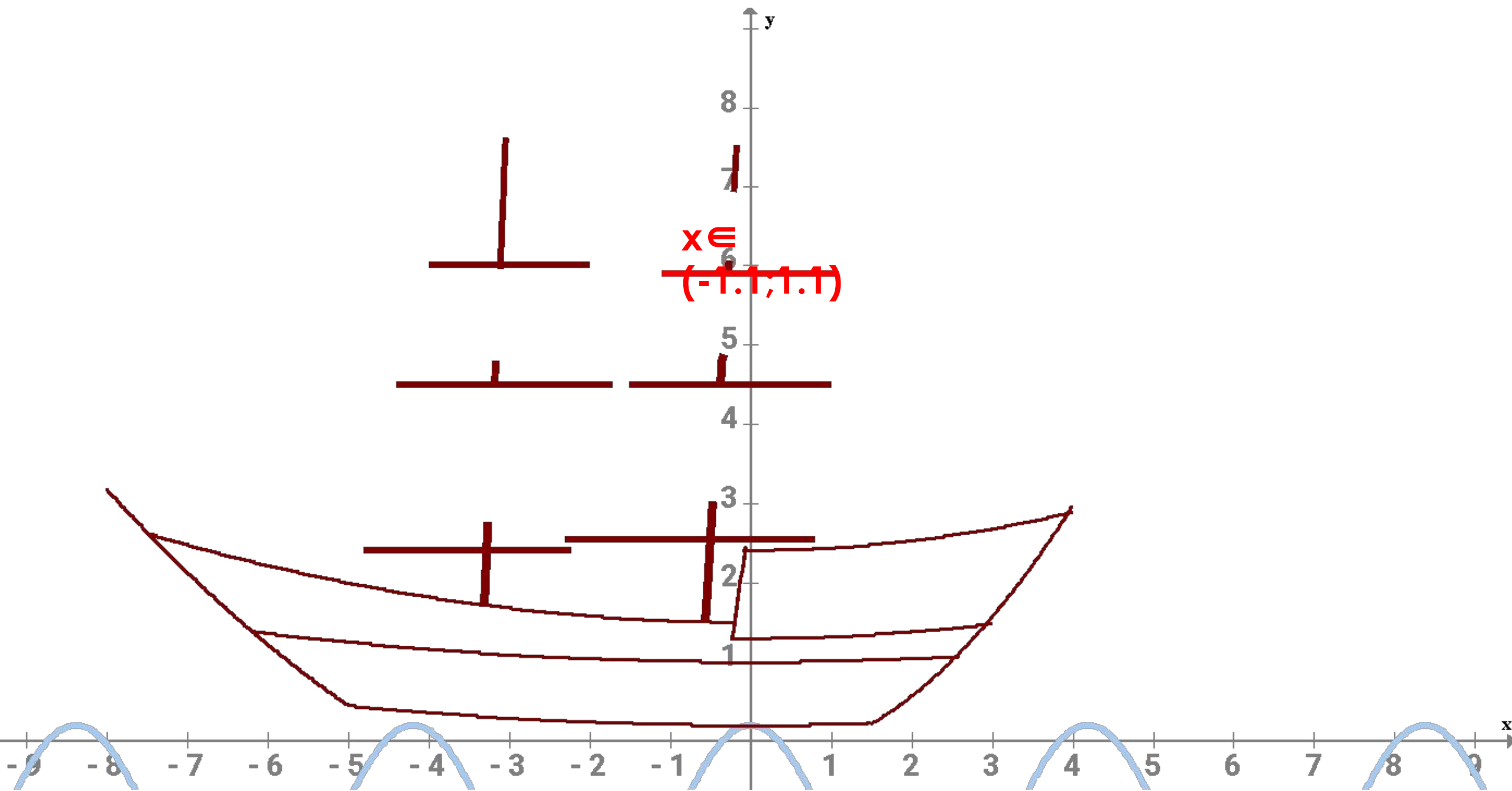

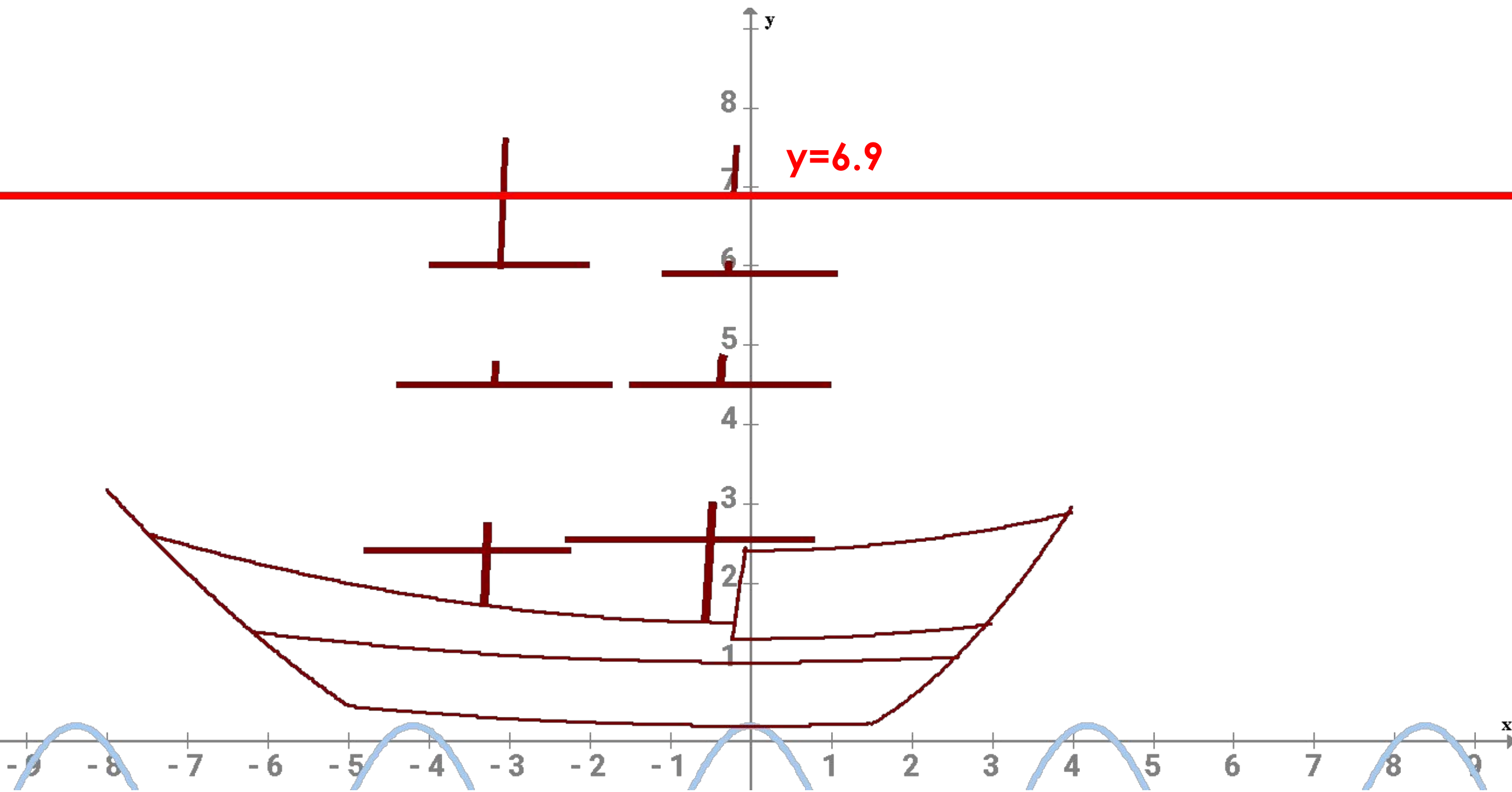

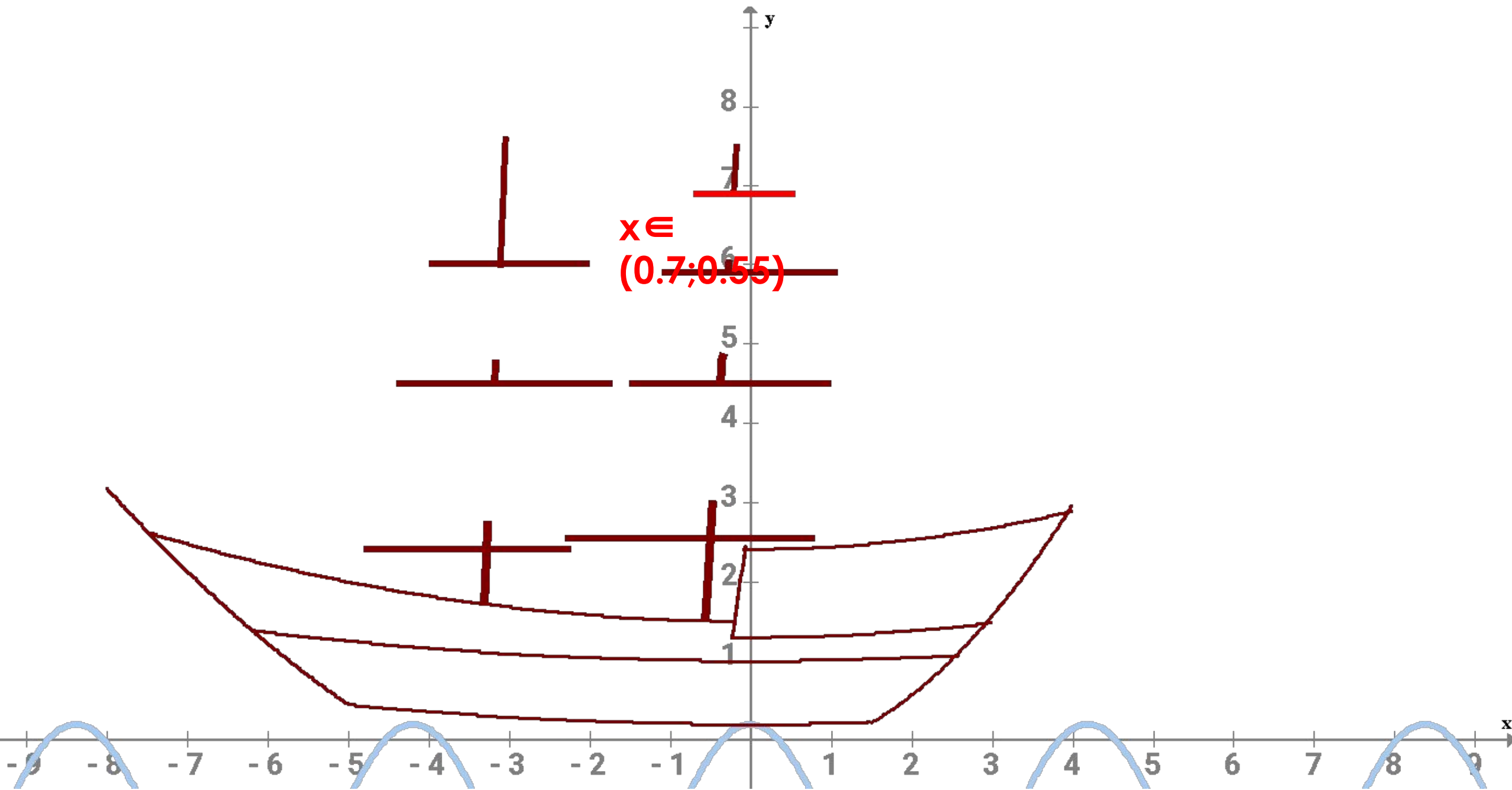

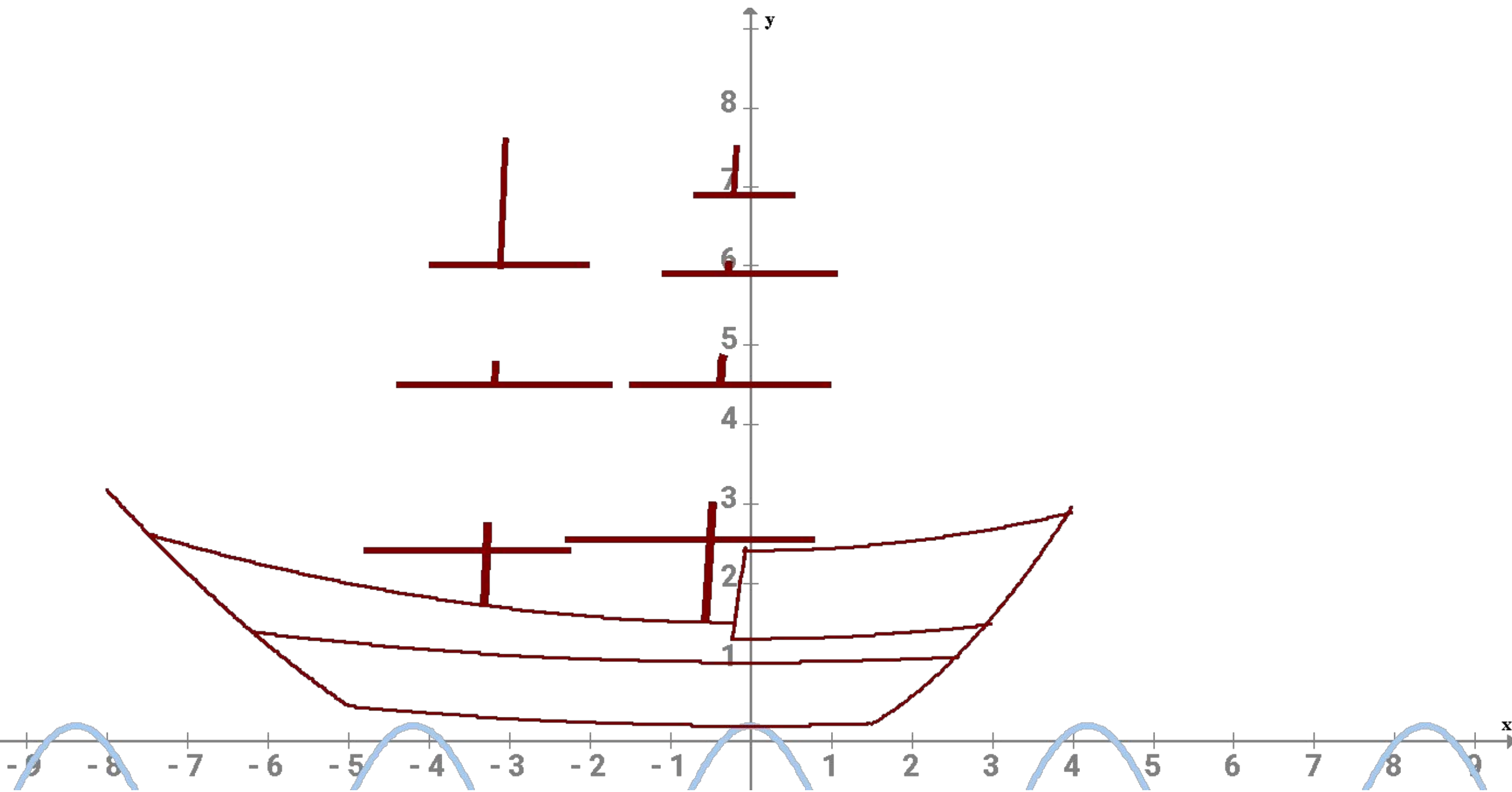

IV этап

- «Паруса»

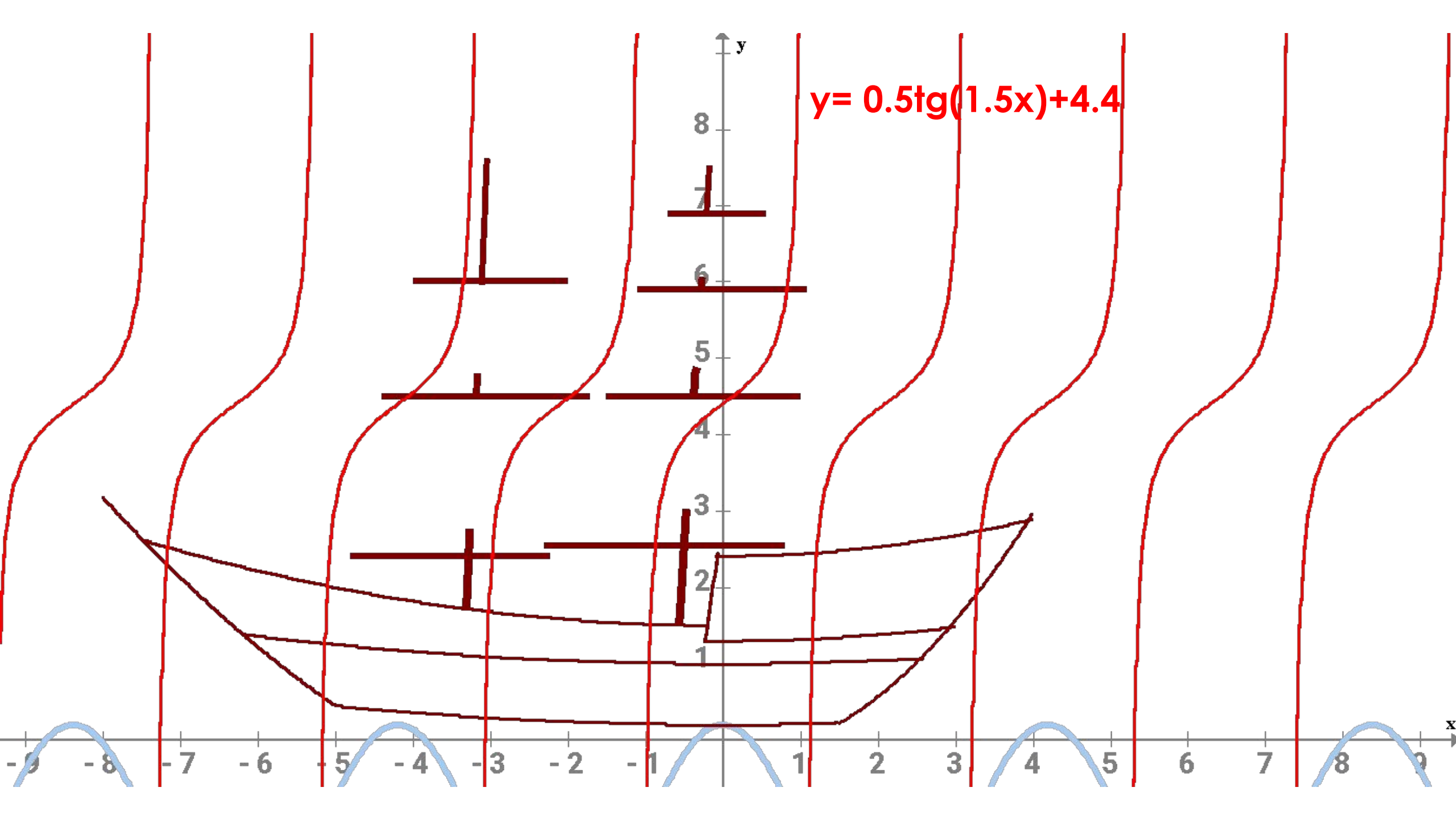

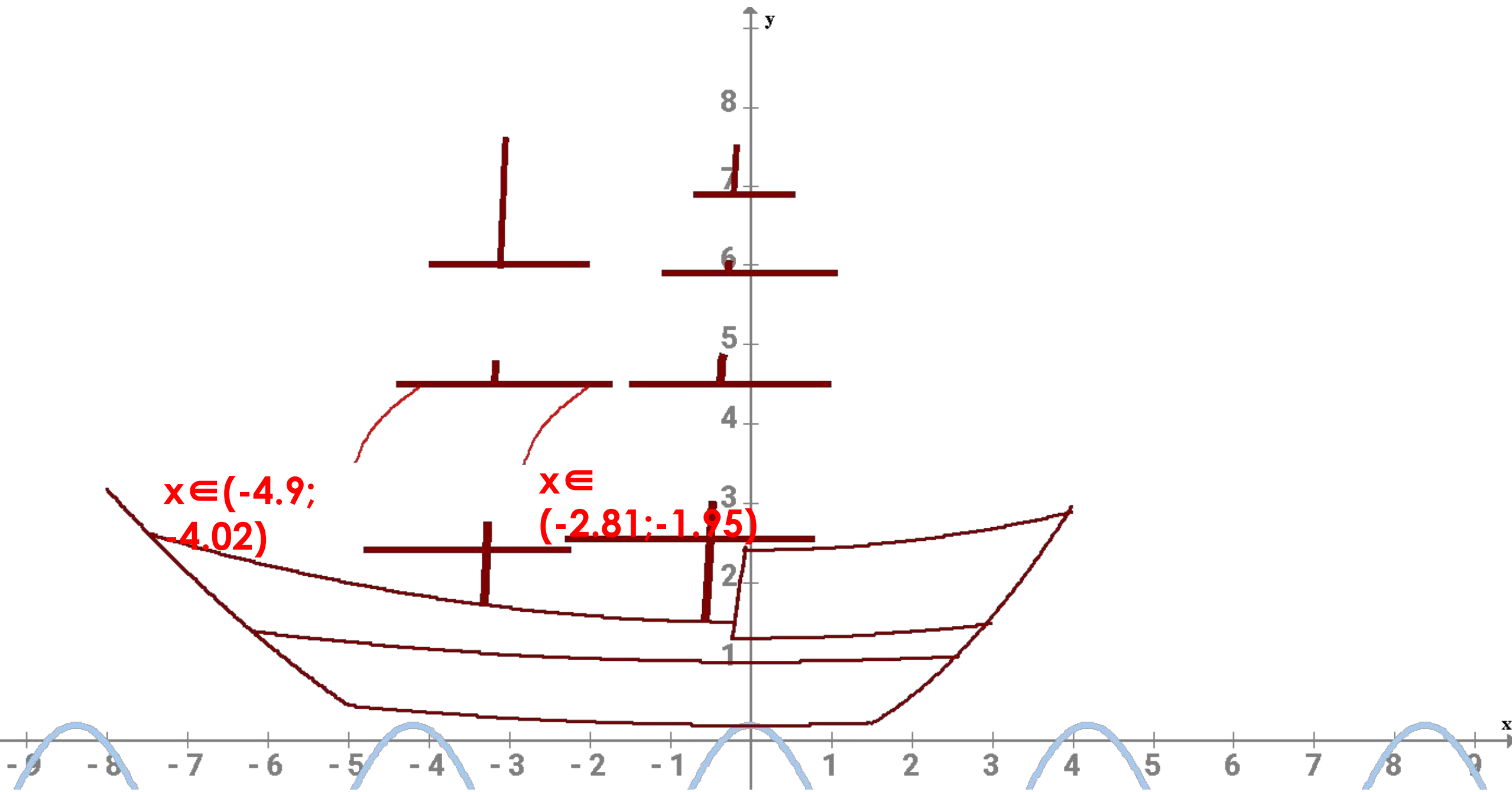

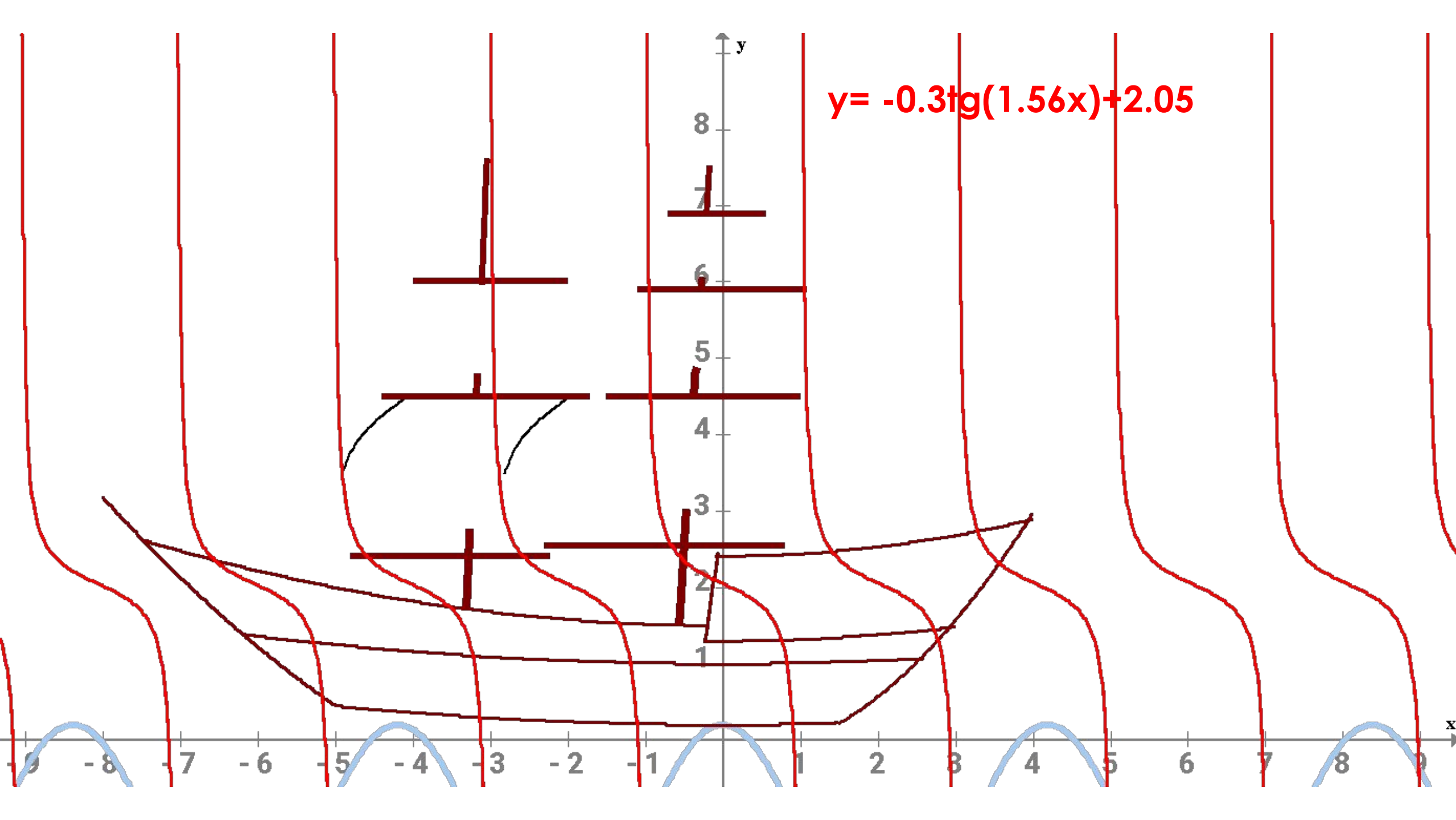



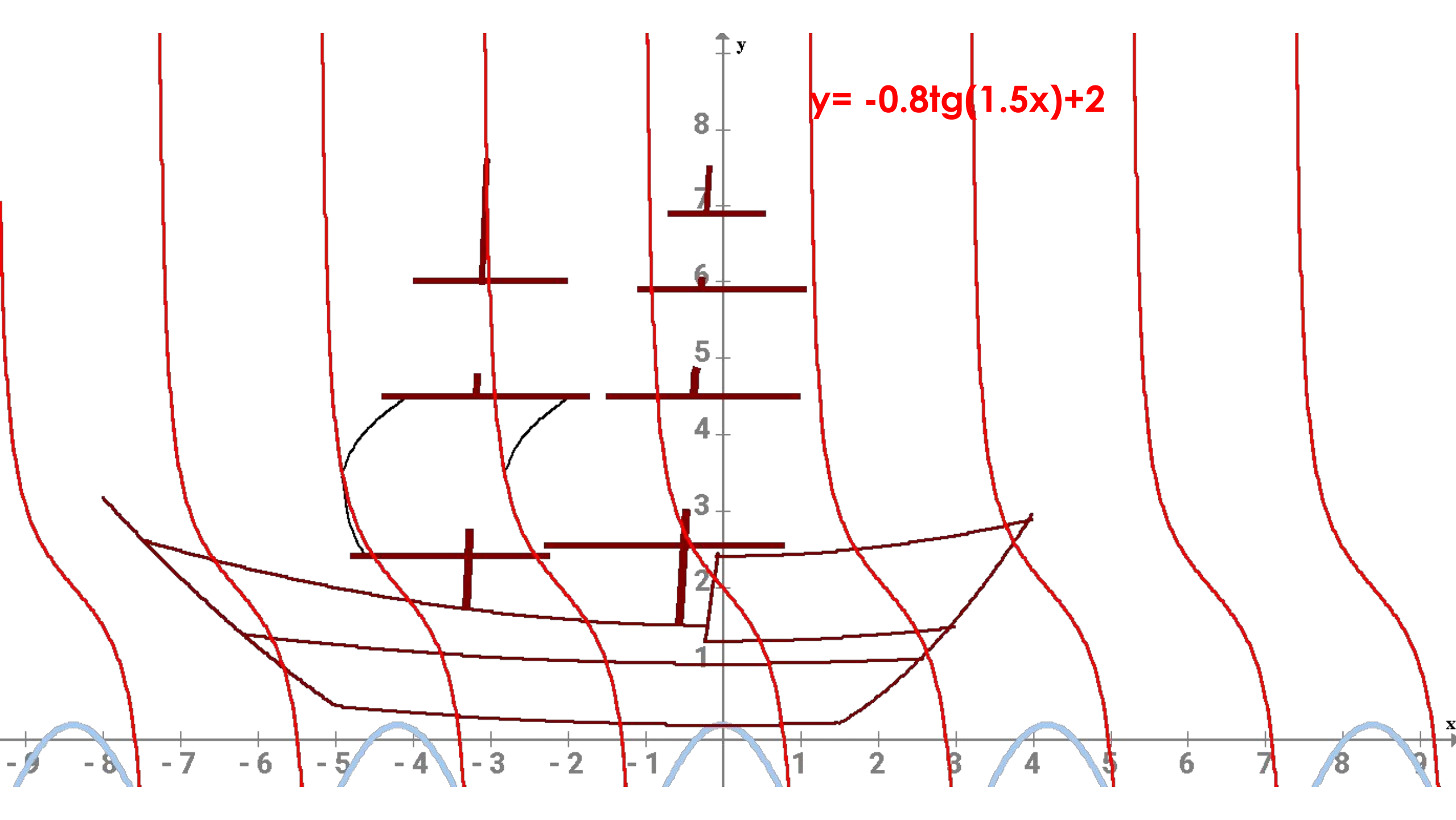

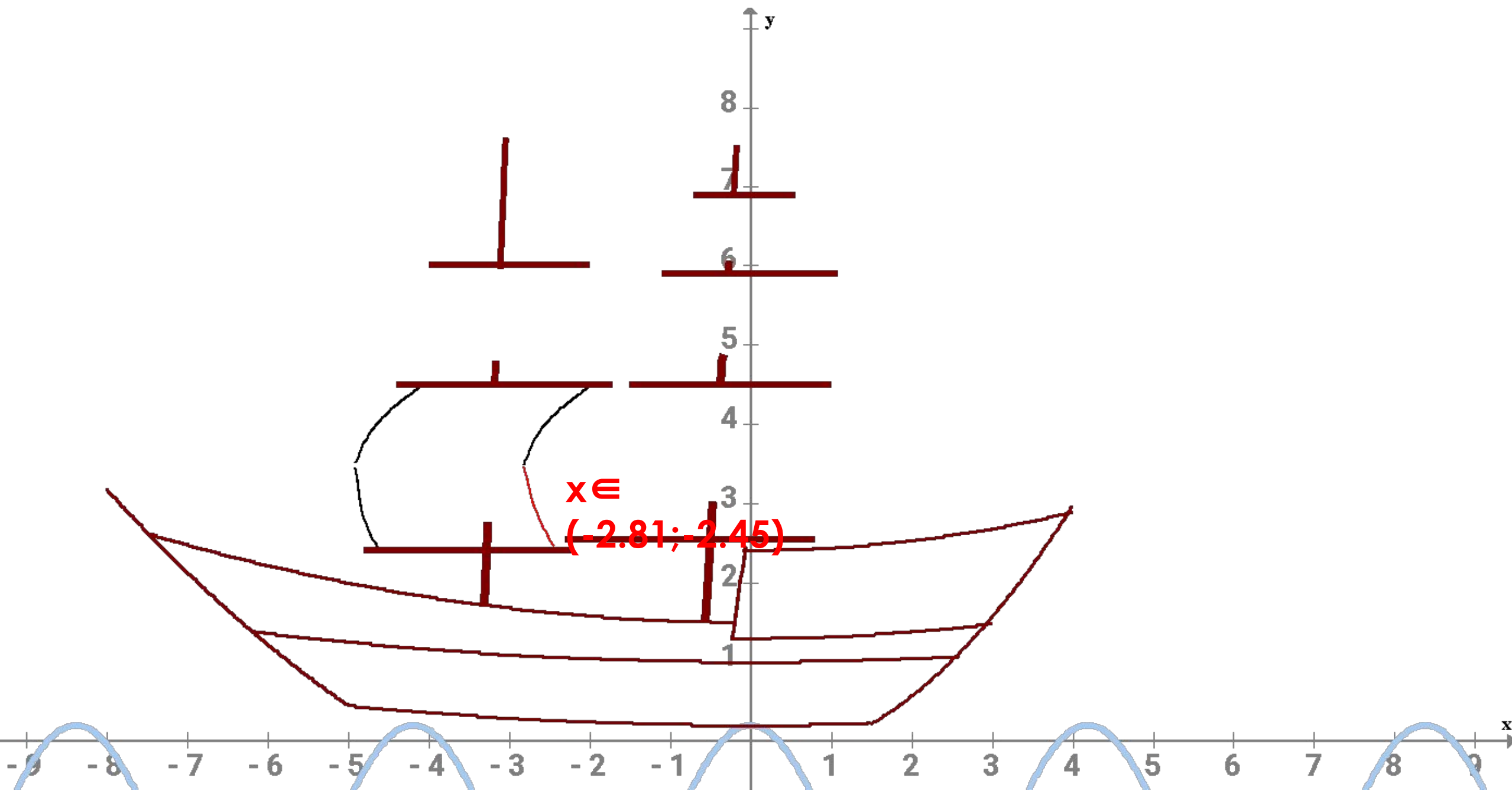

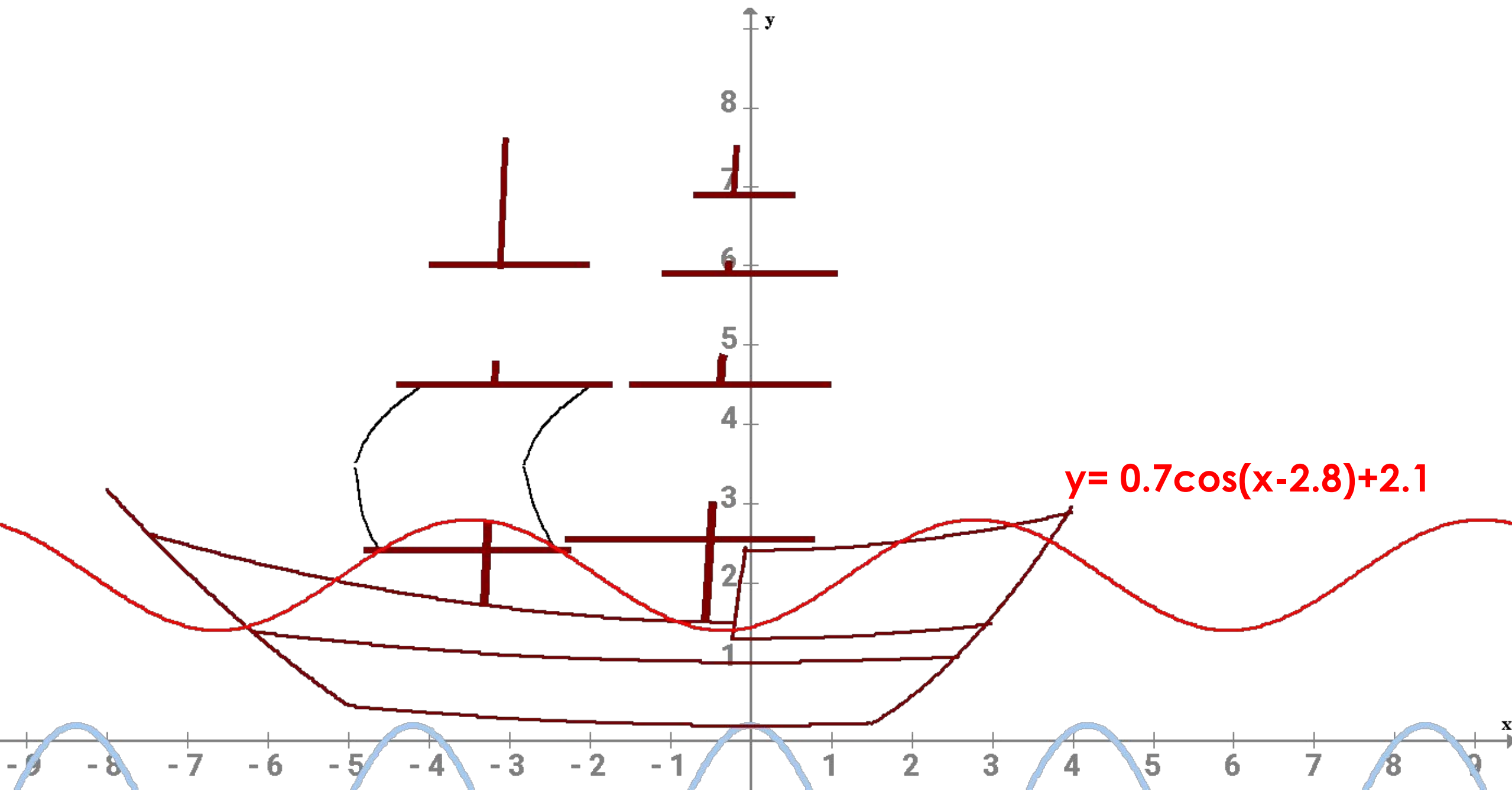

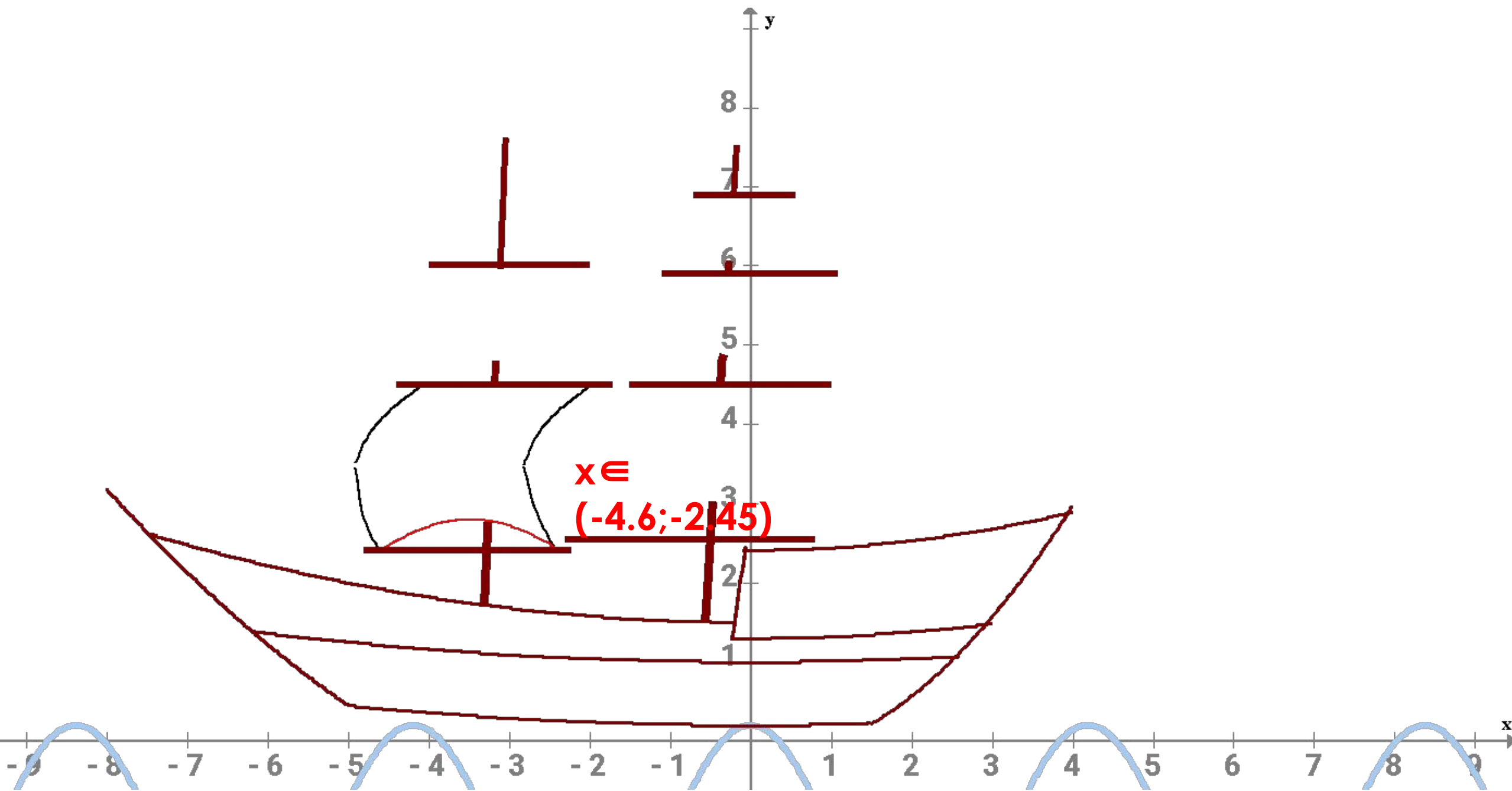

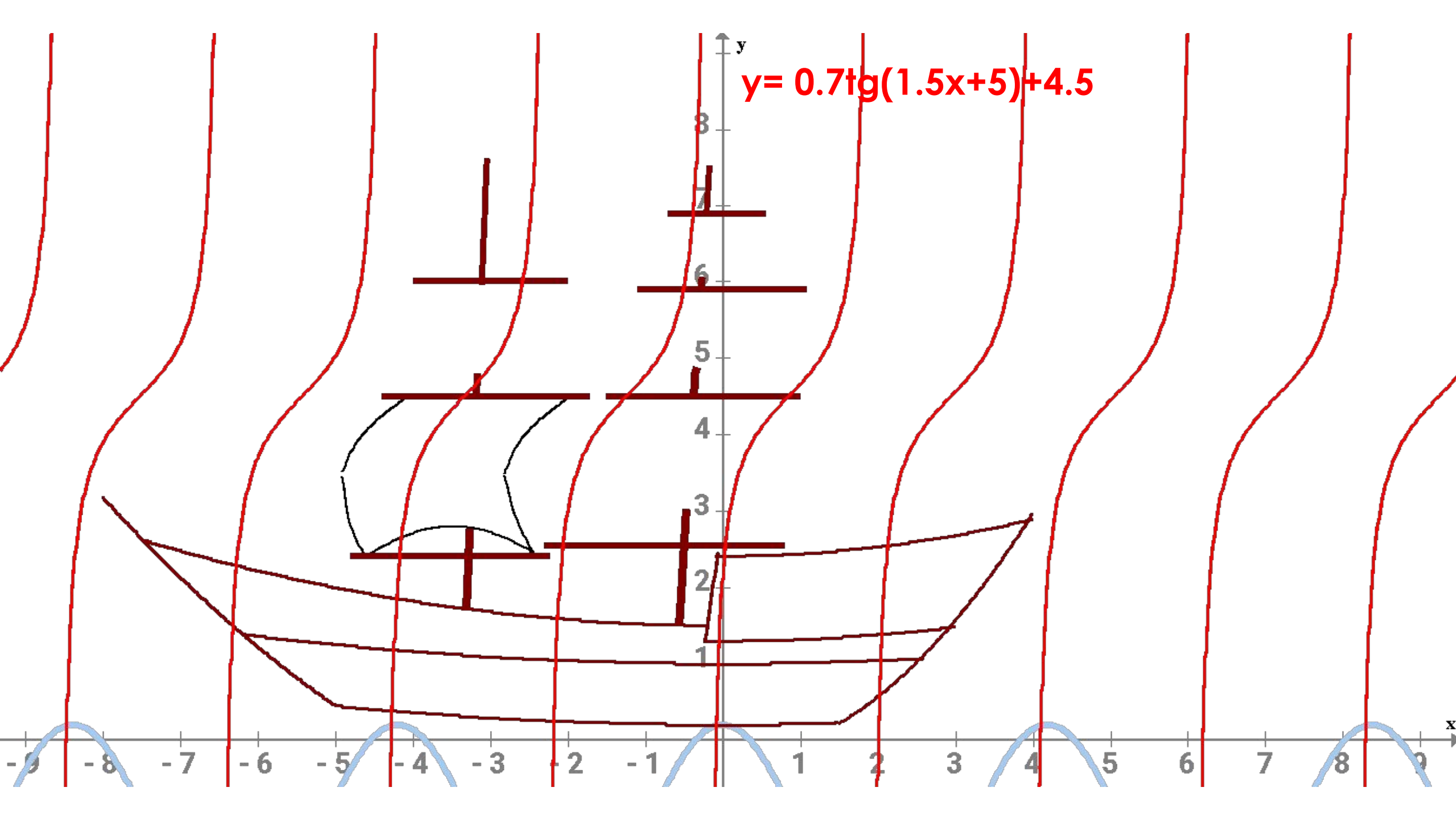

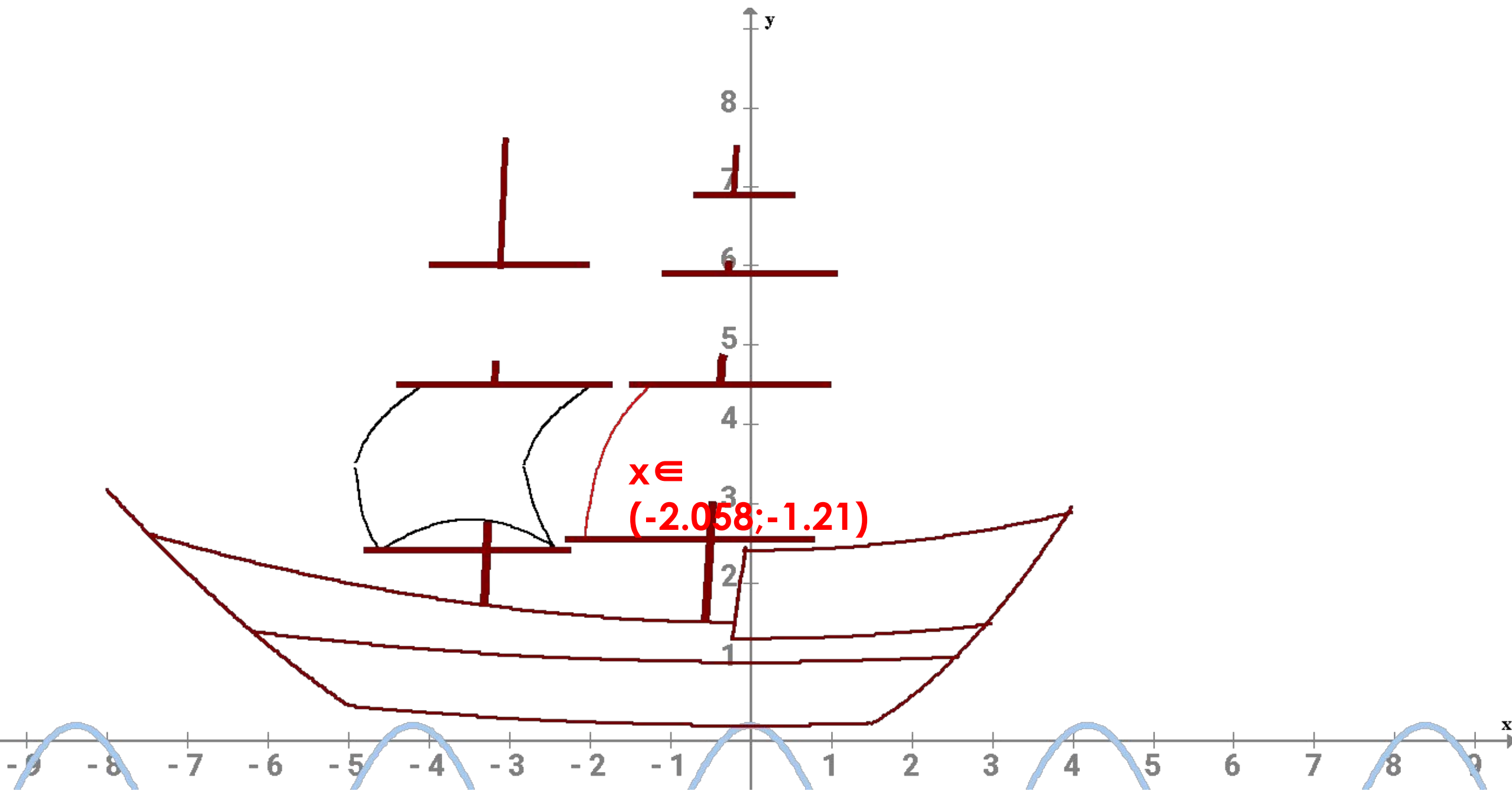

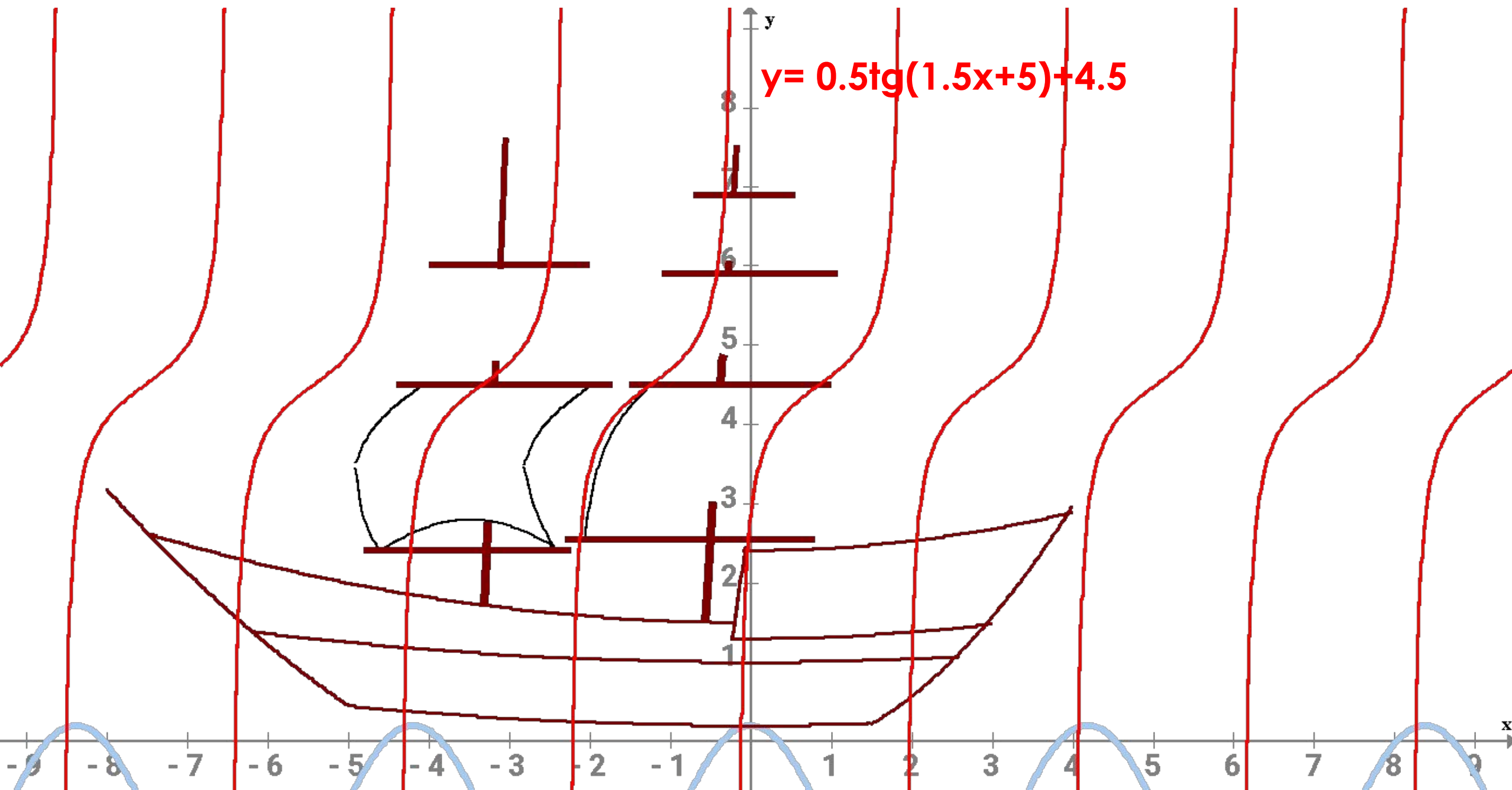

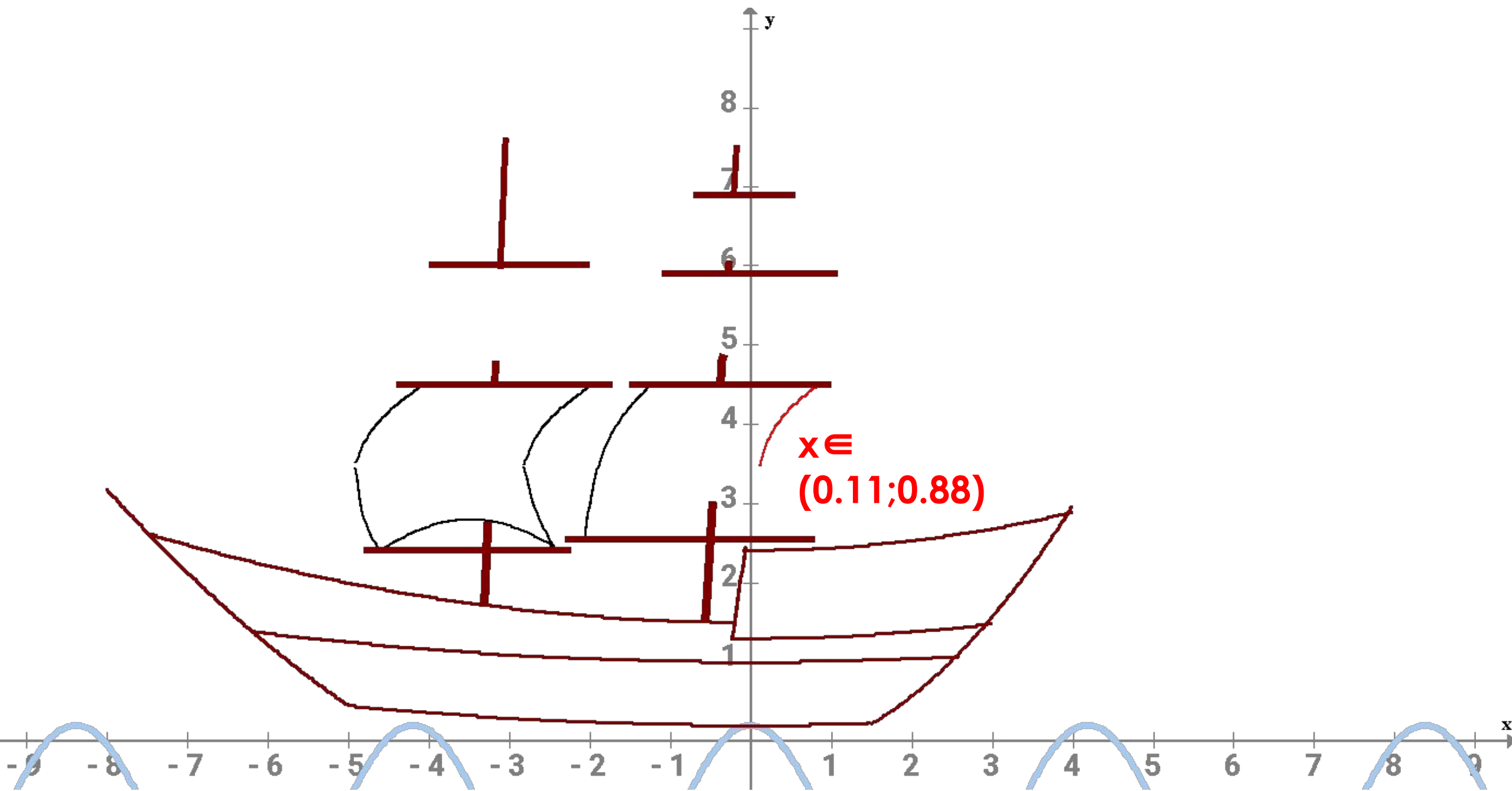

$y = -0.3 \operatorname{tg}(x + 4.8) + 2.16$

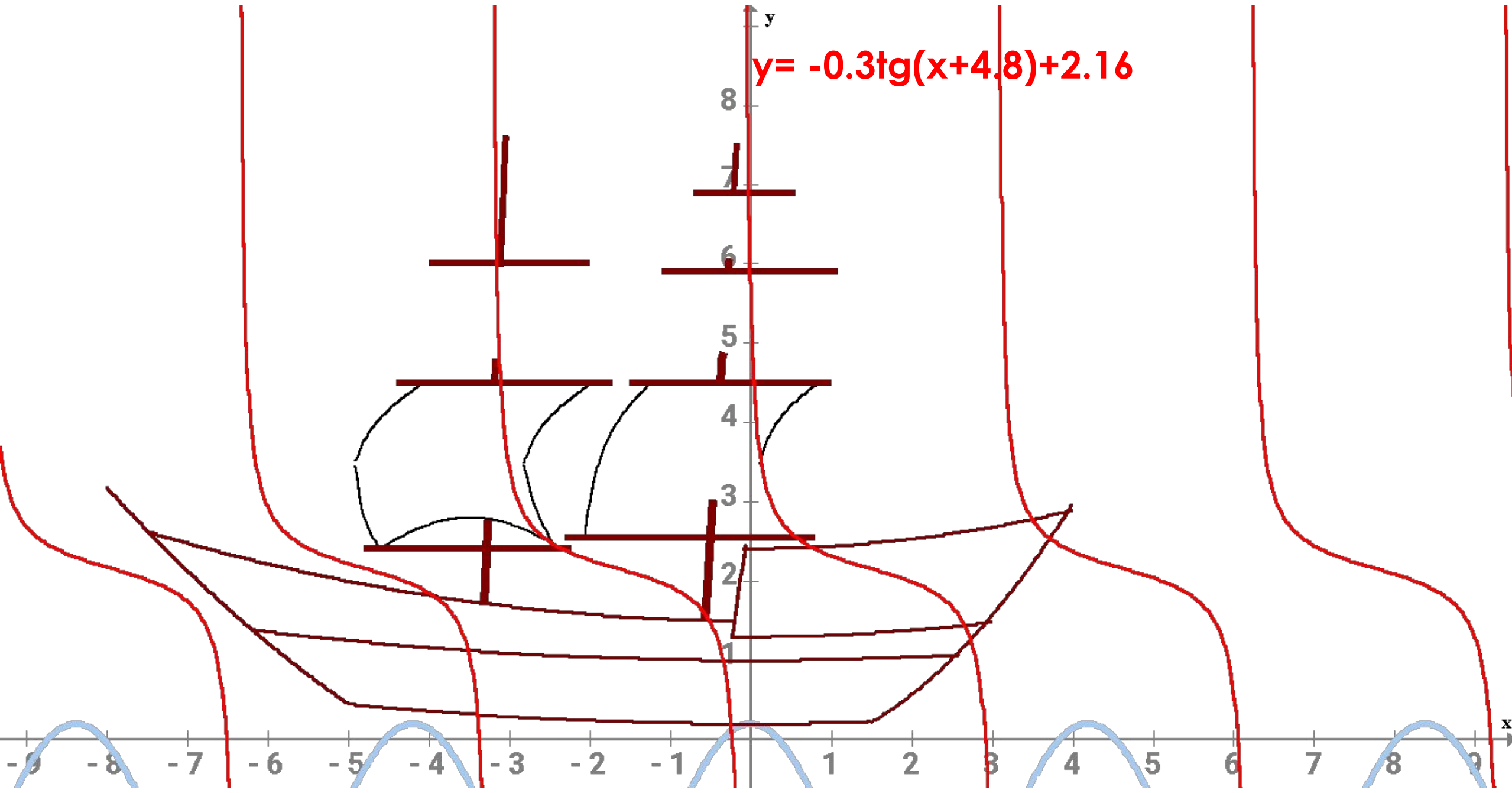

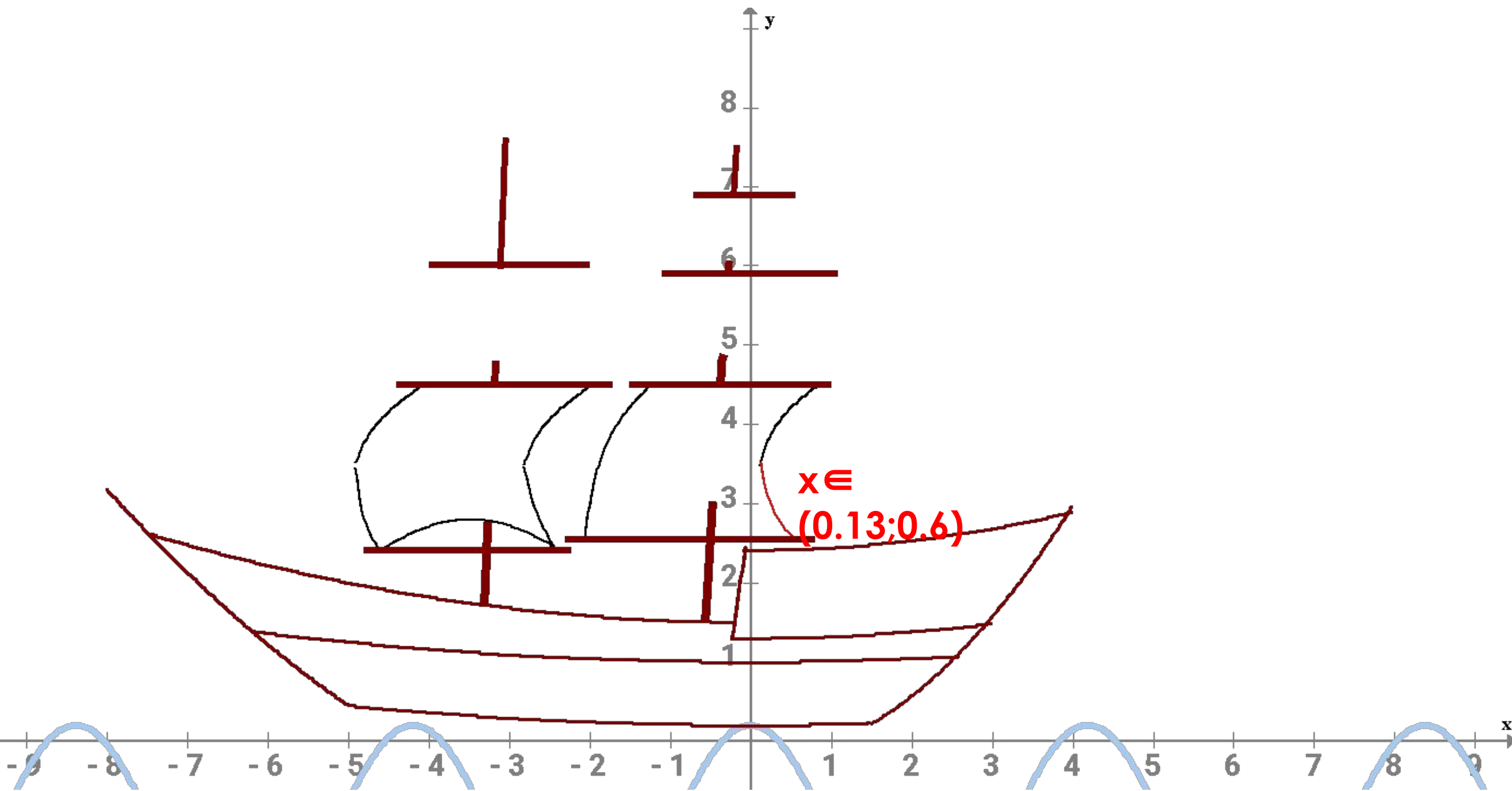

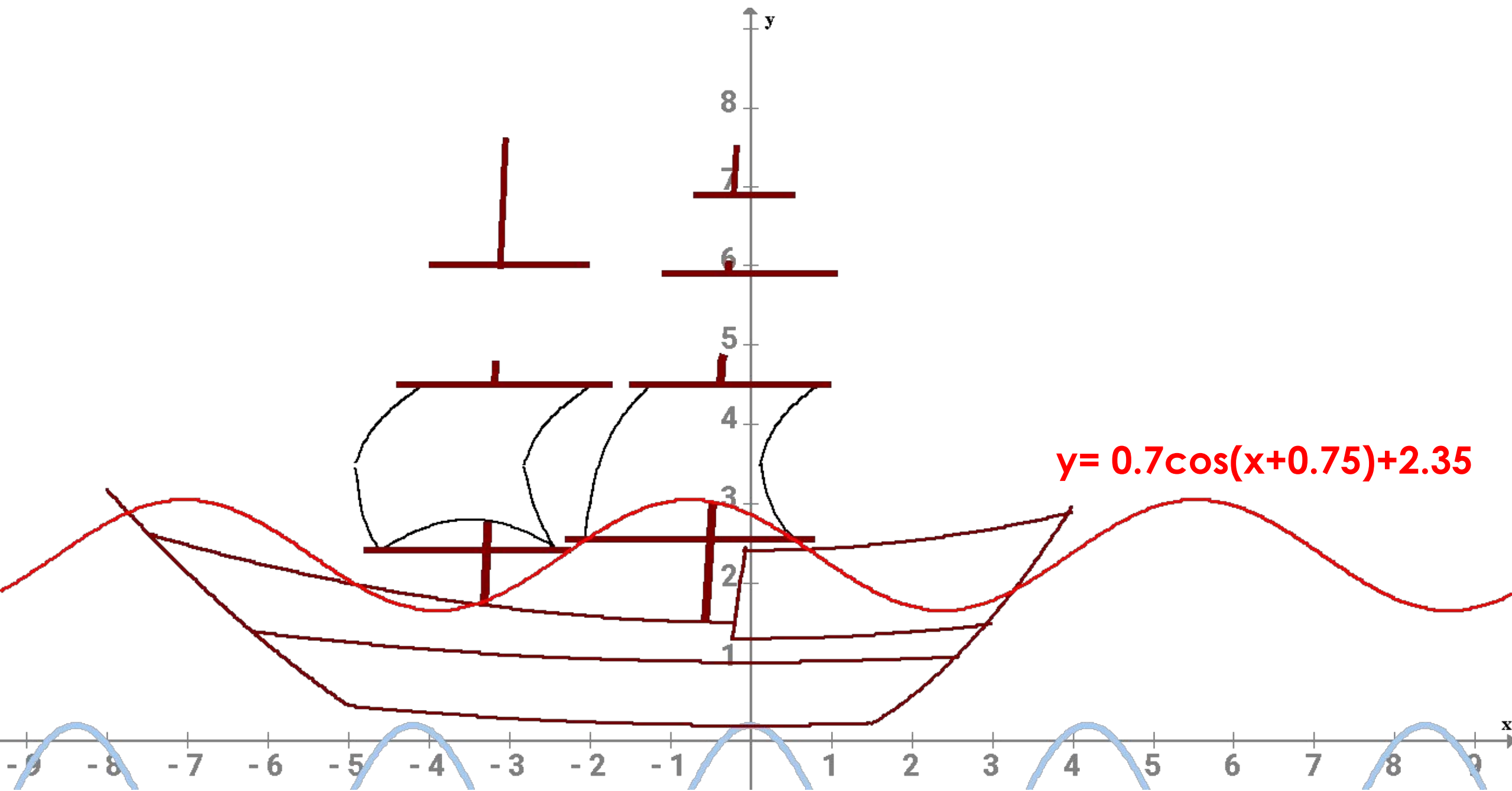

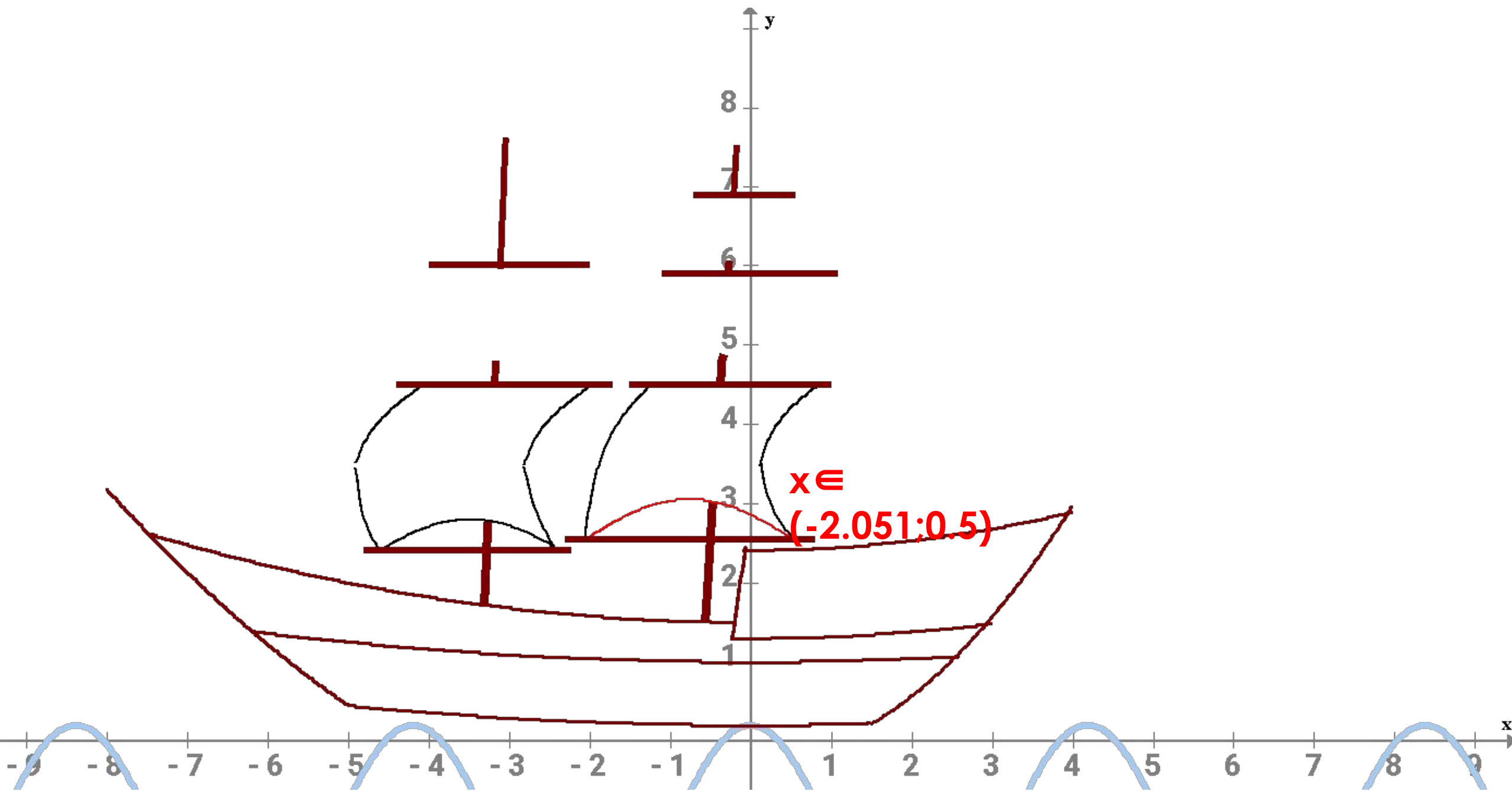

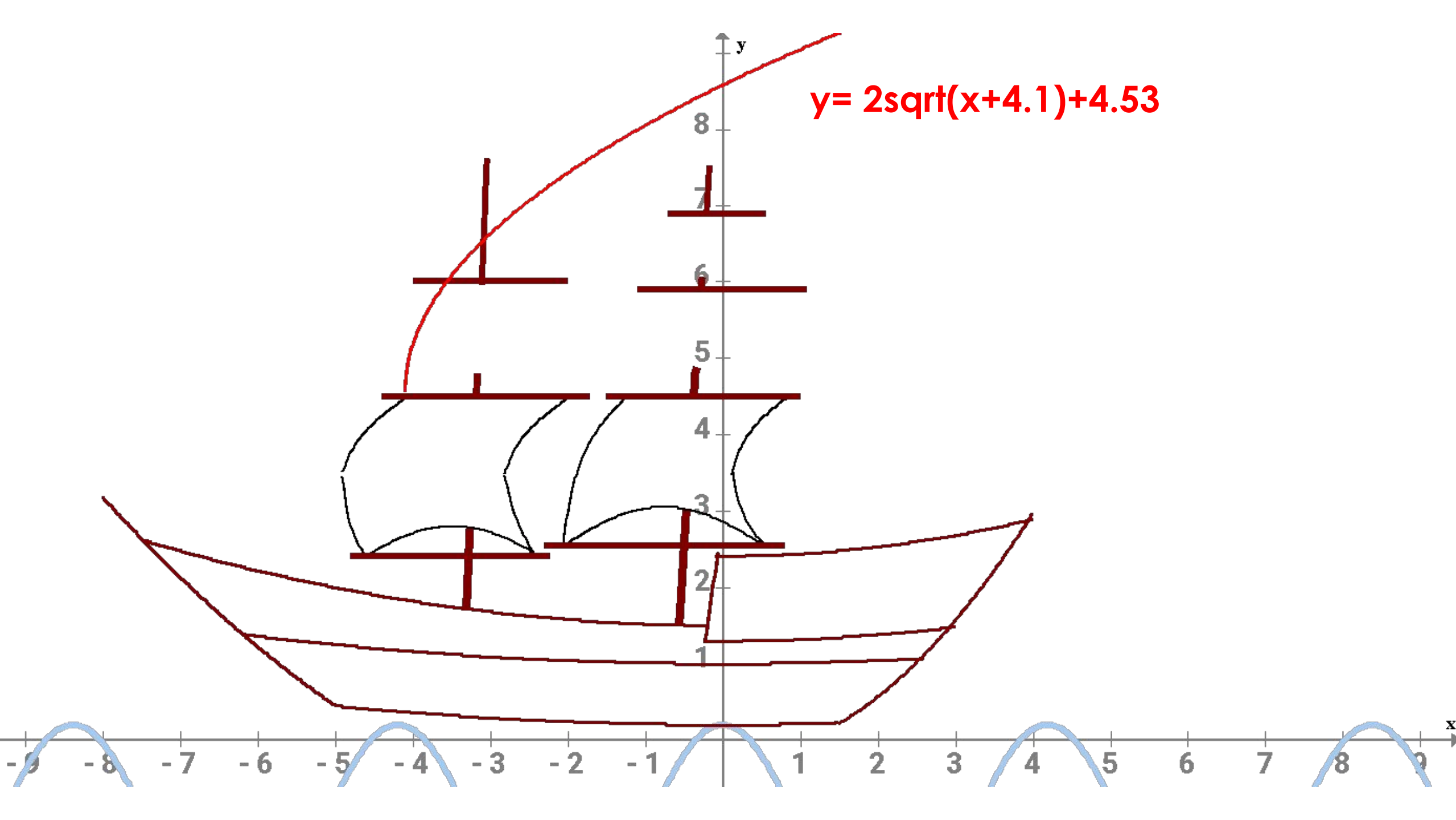

$$y = 2\sqrt{x+4.1} + 4.53$$

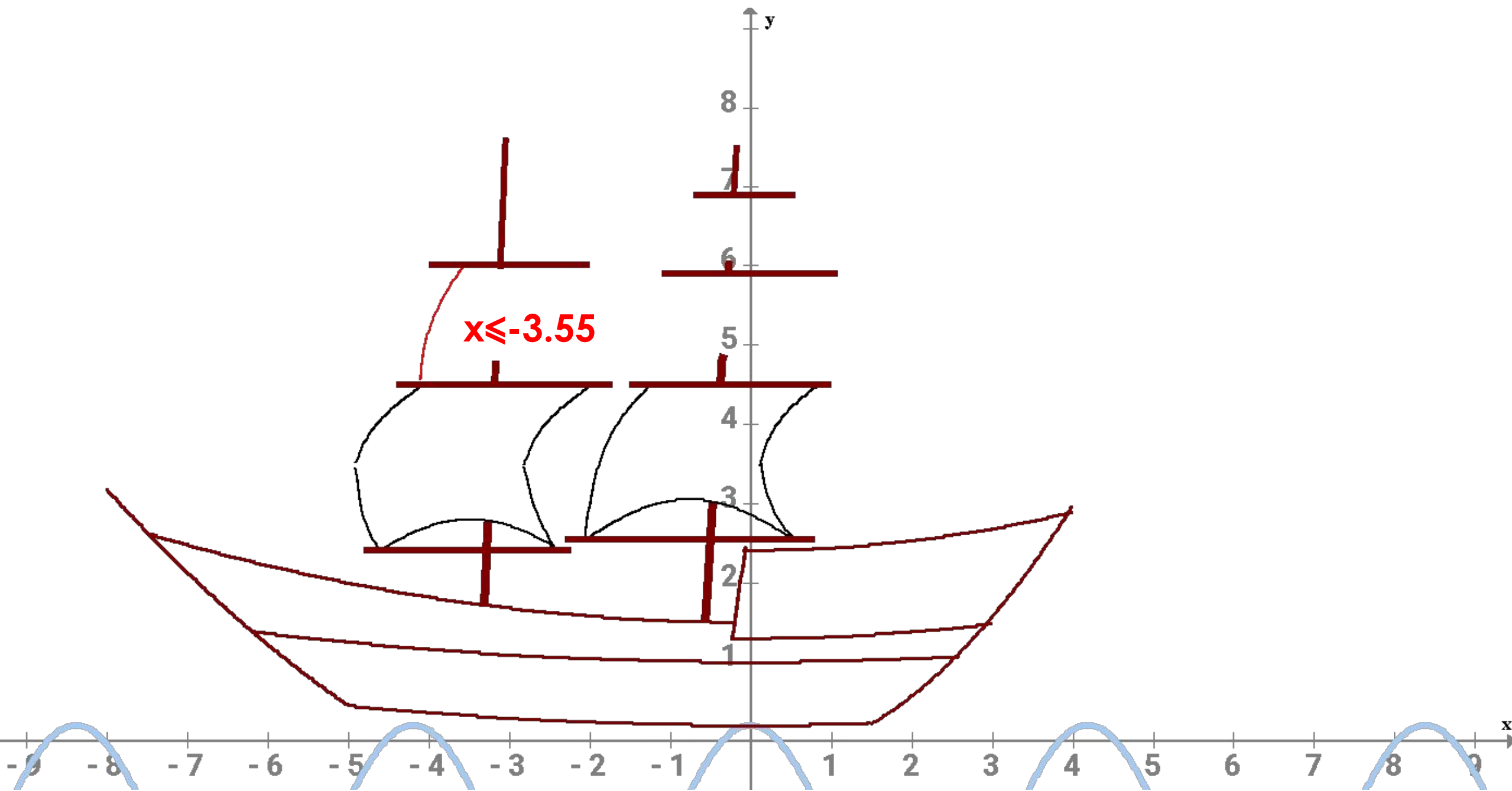

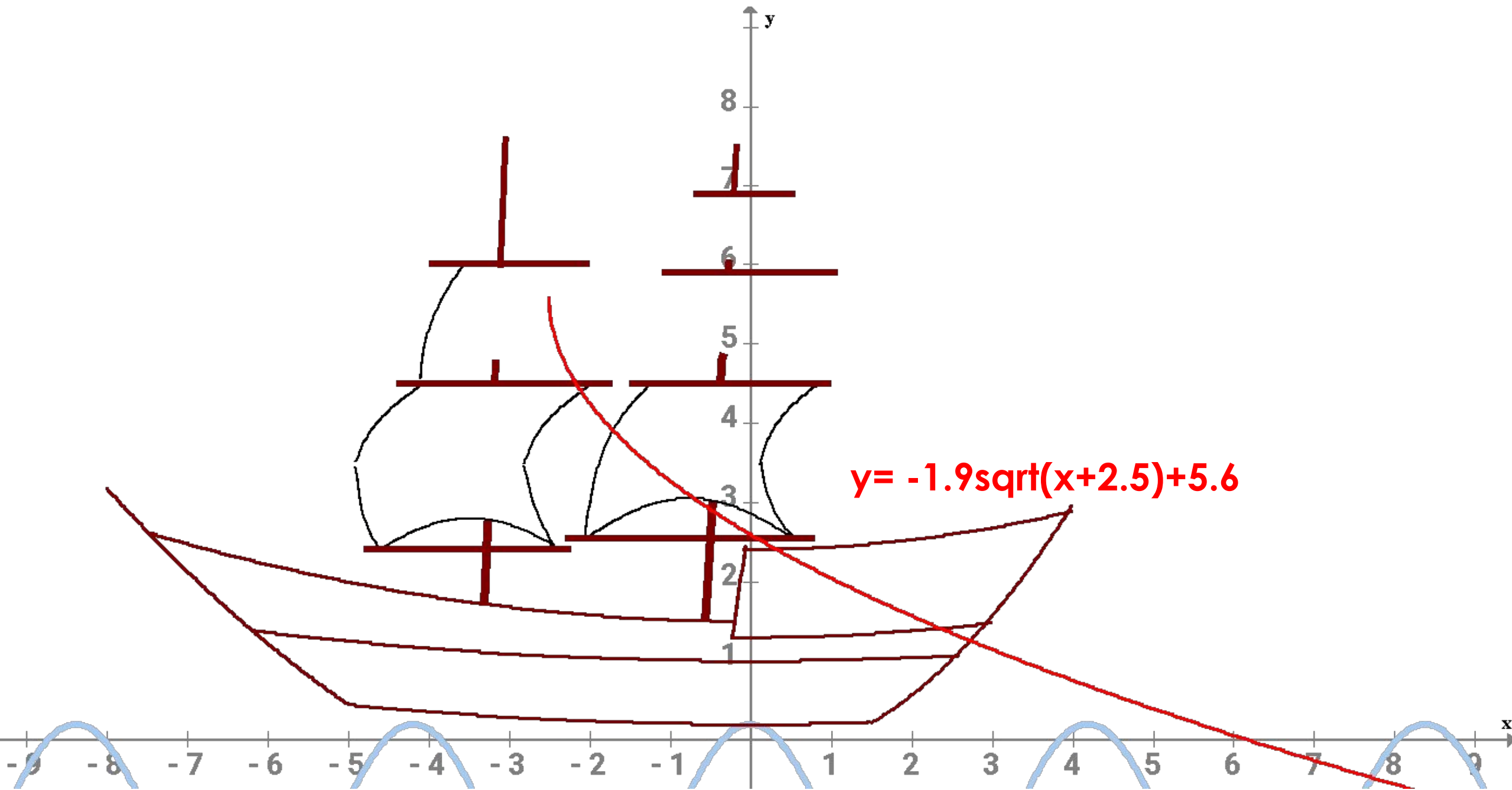

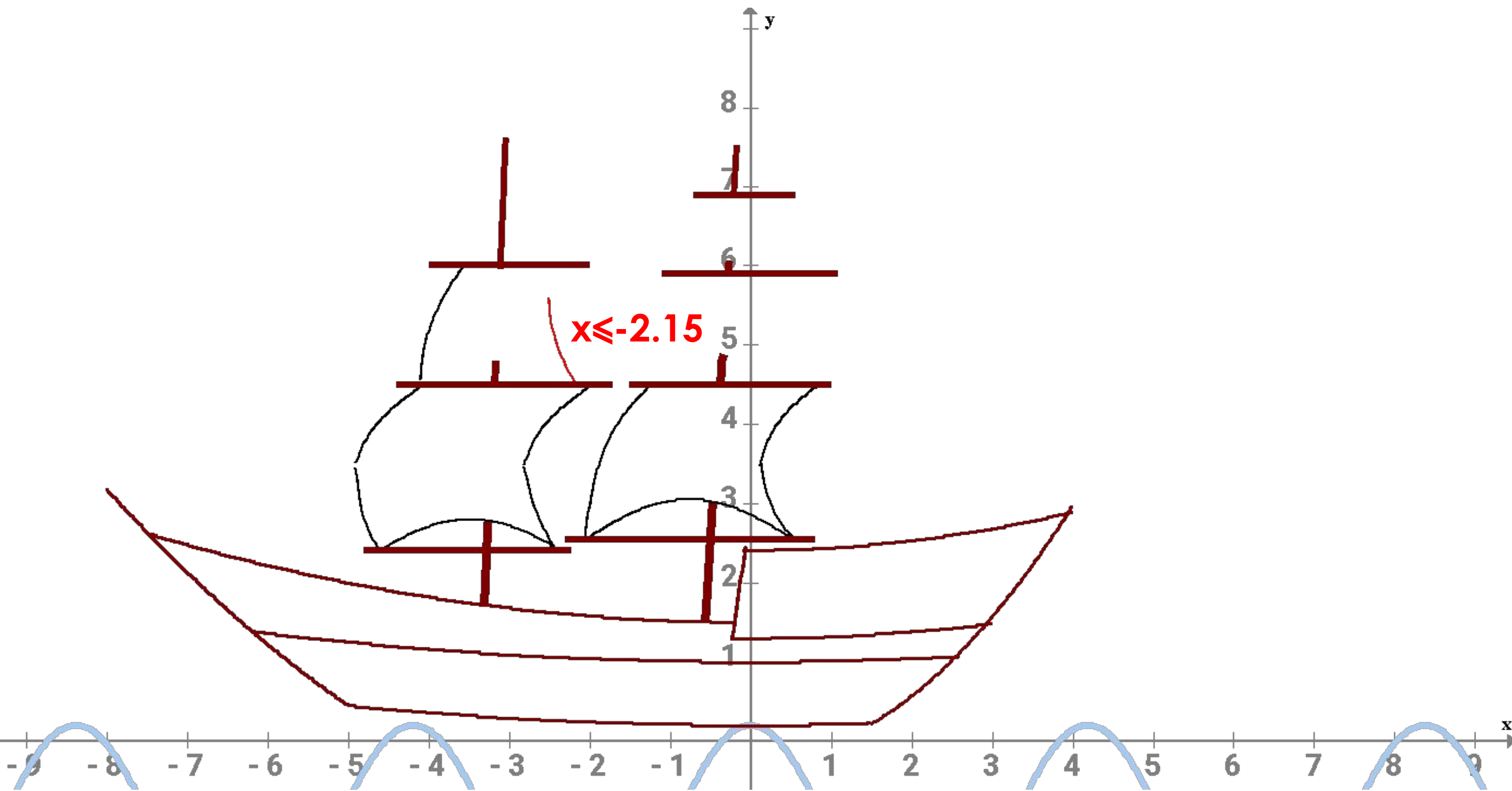

$$y = \sqrt{x+2.5} + 5.6$$

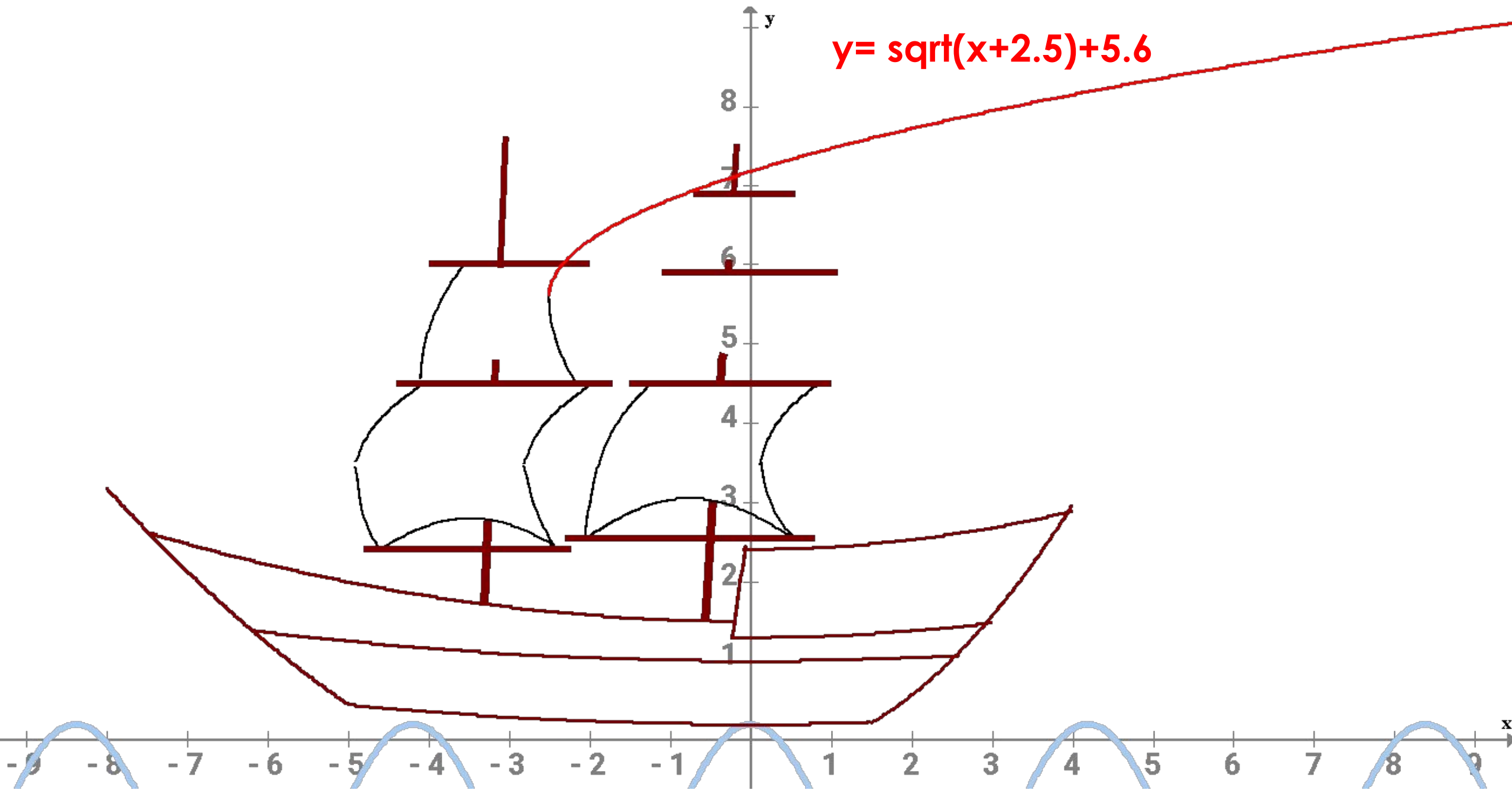

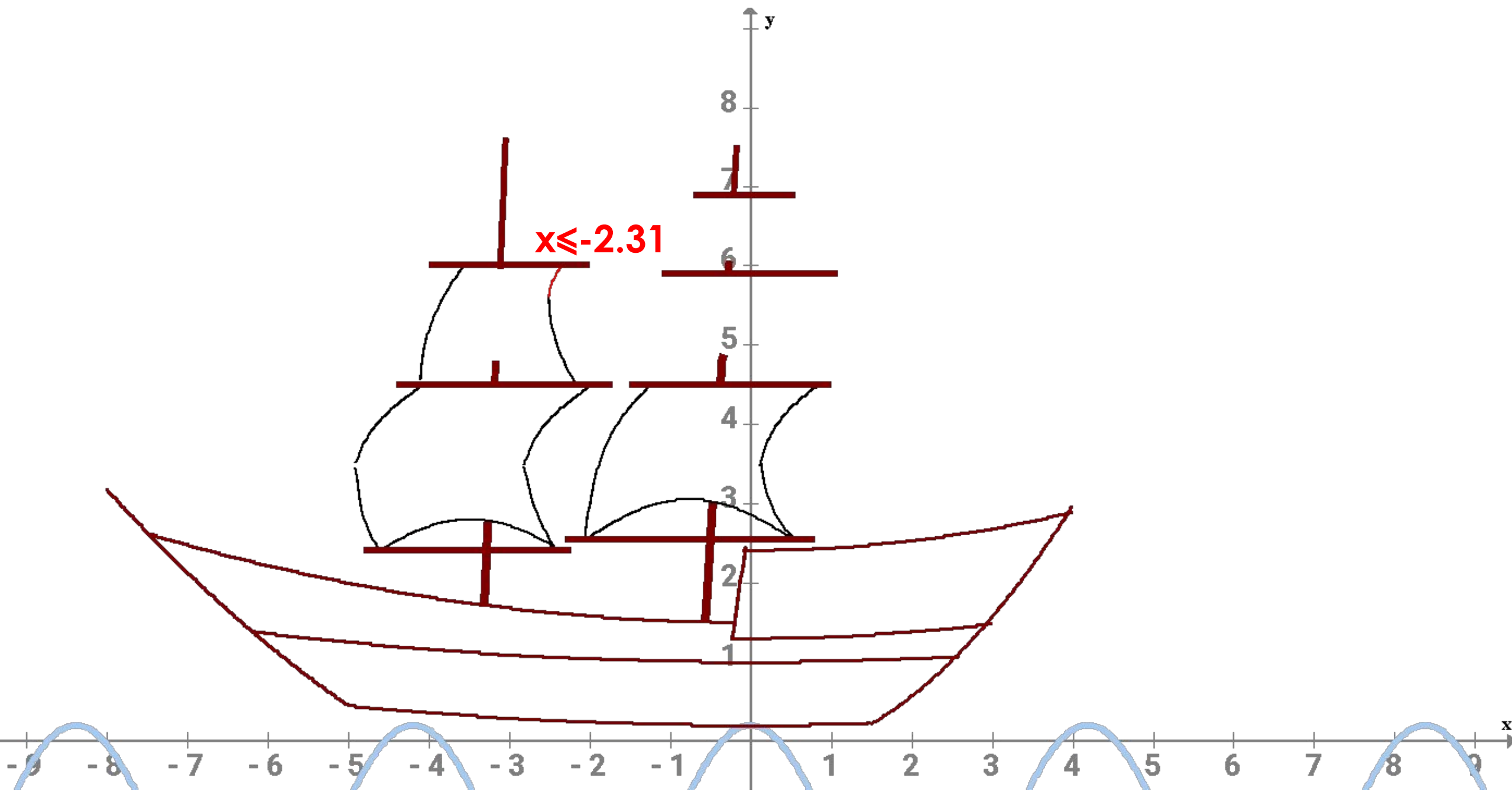

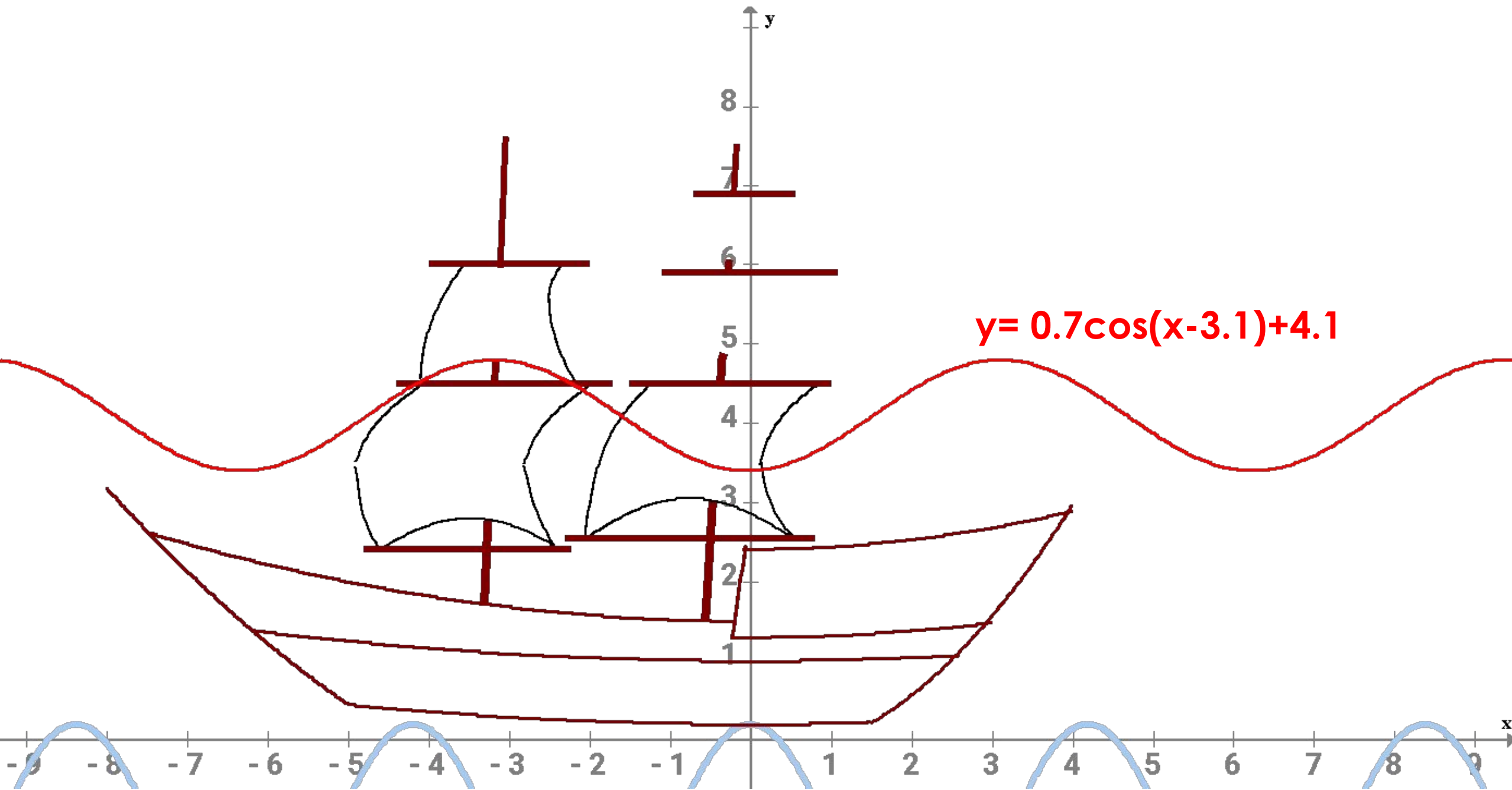

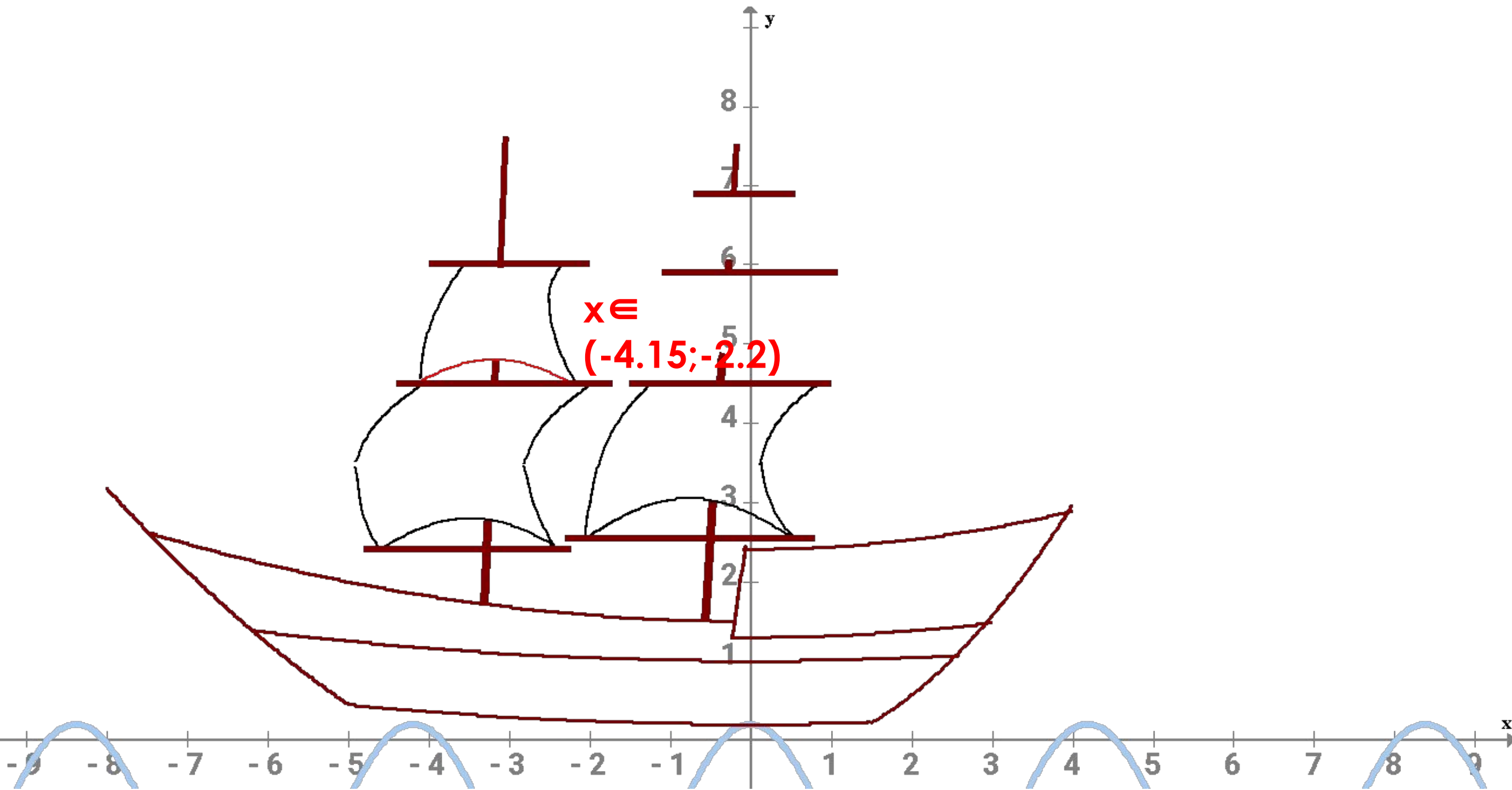

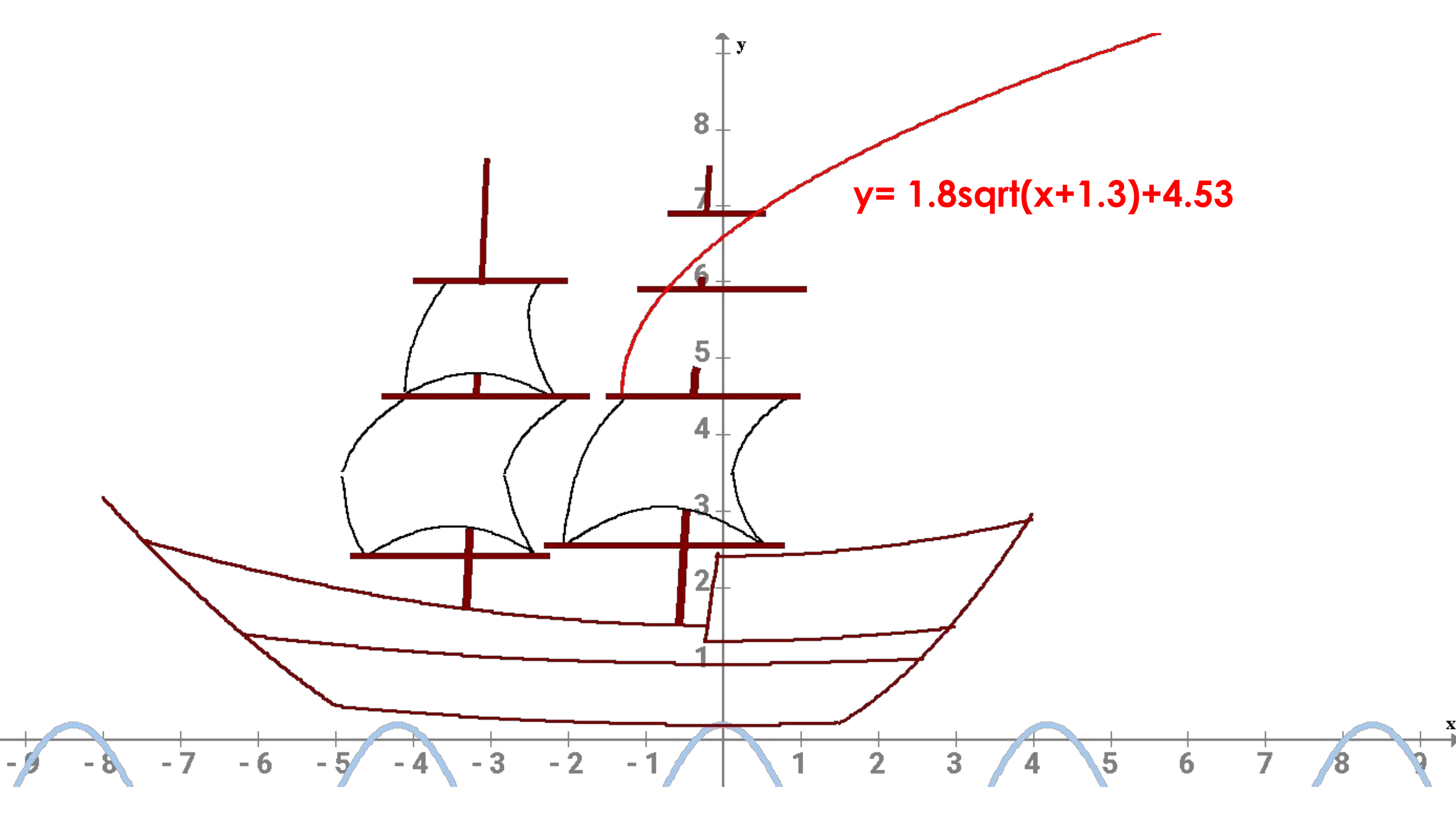

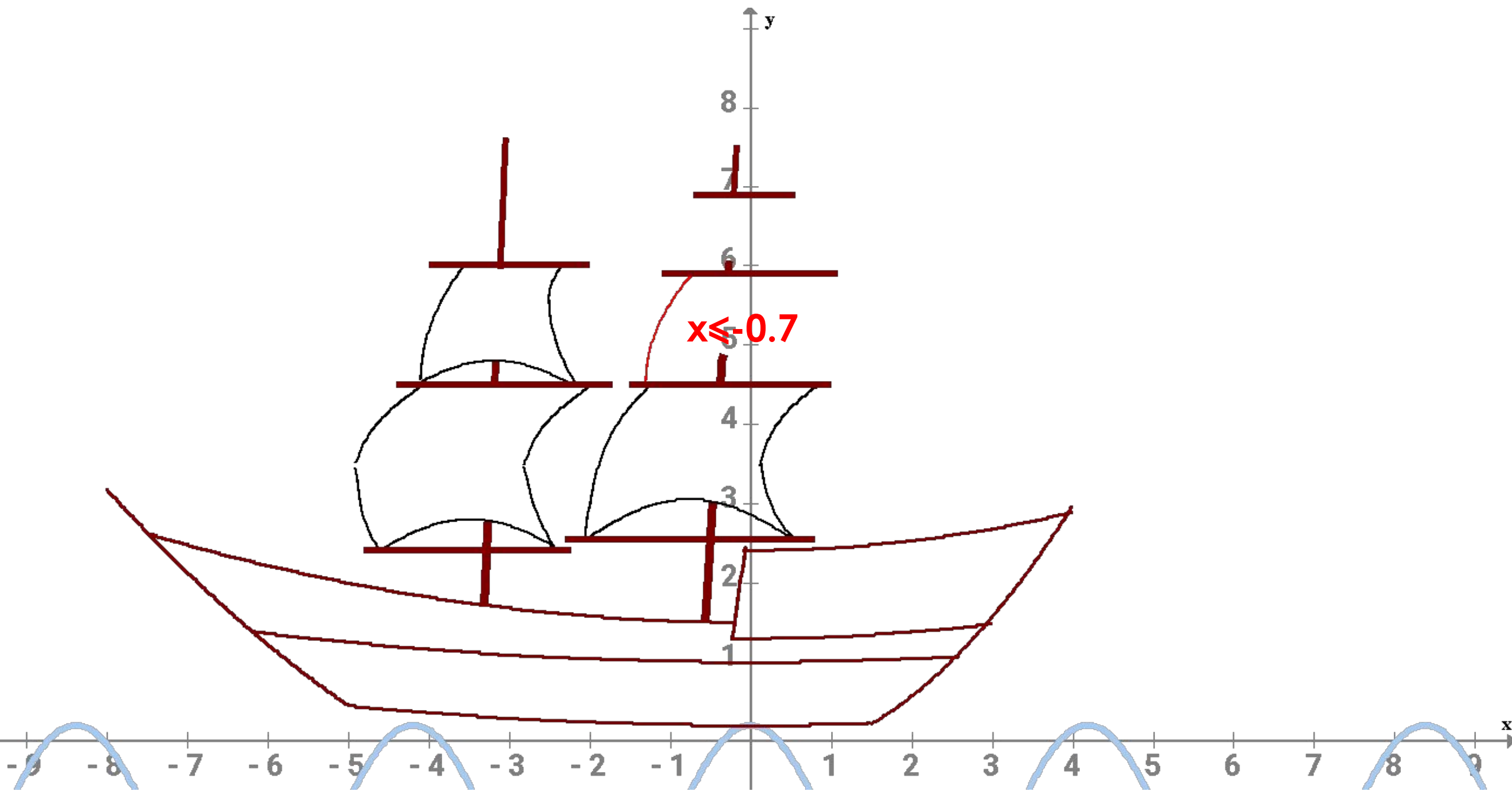

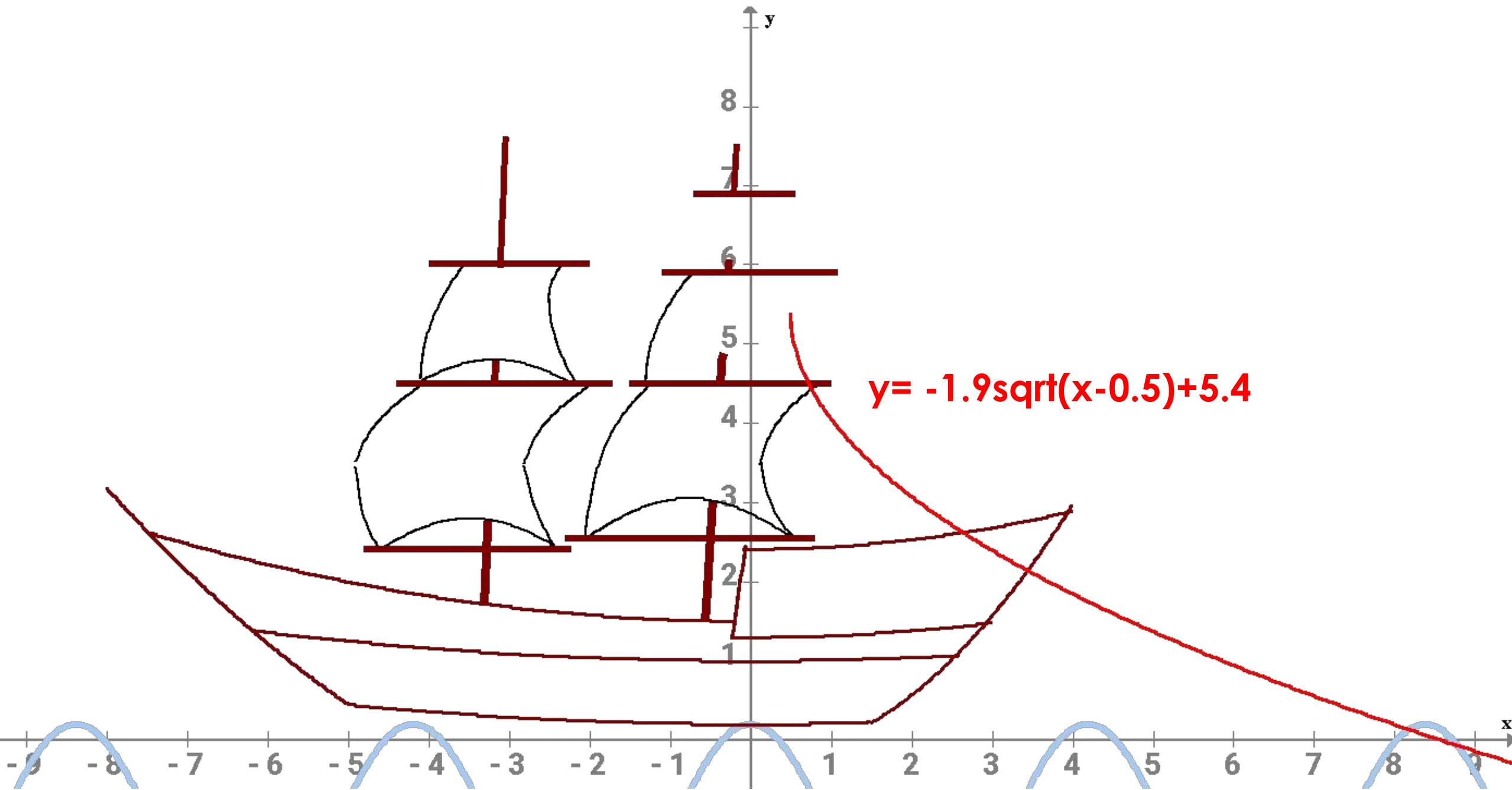

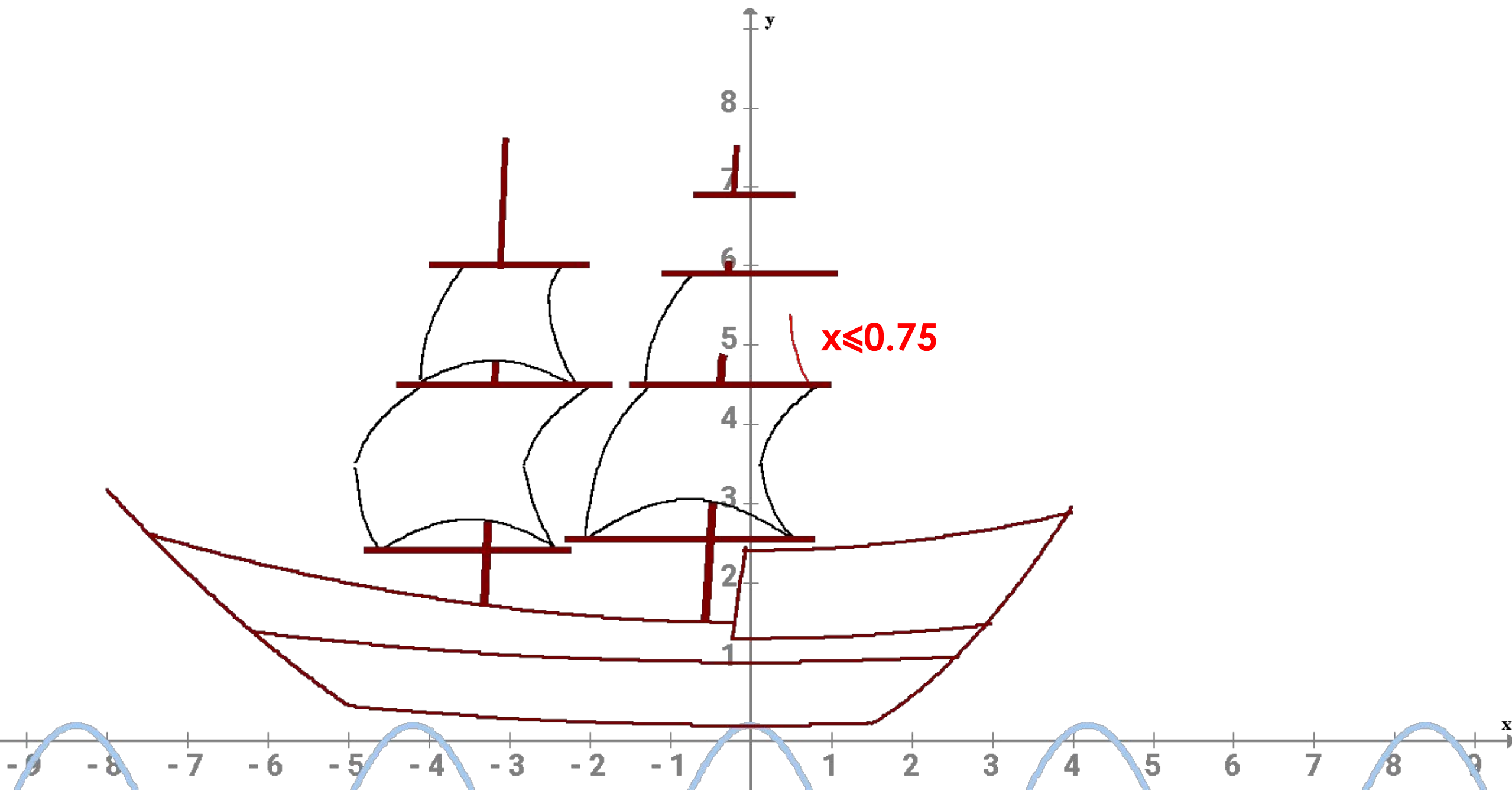

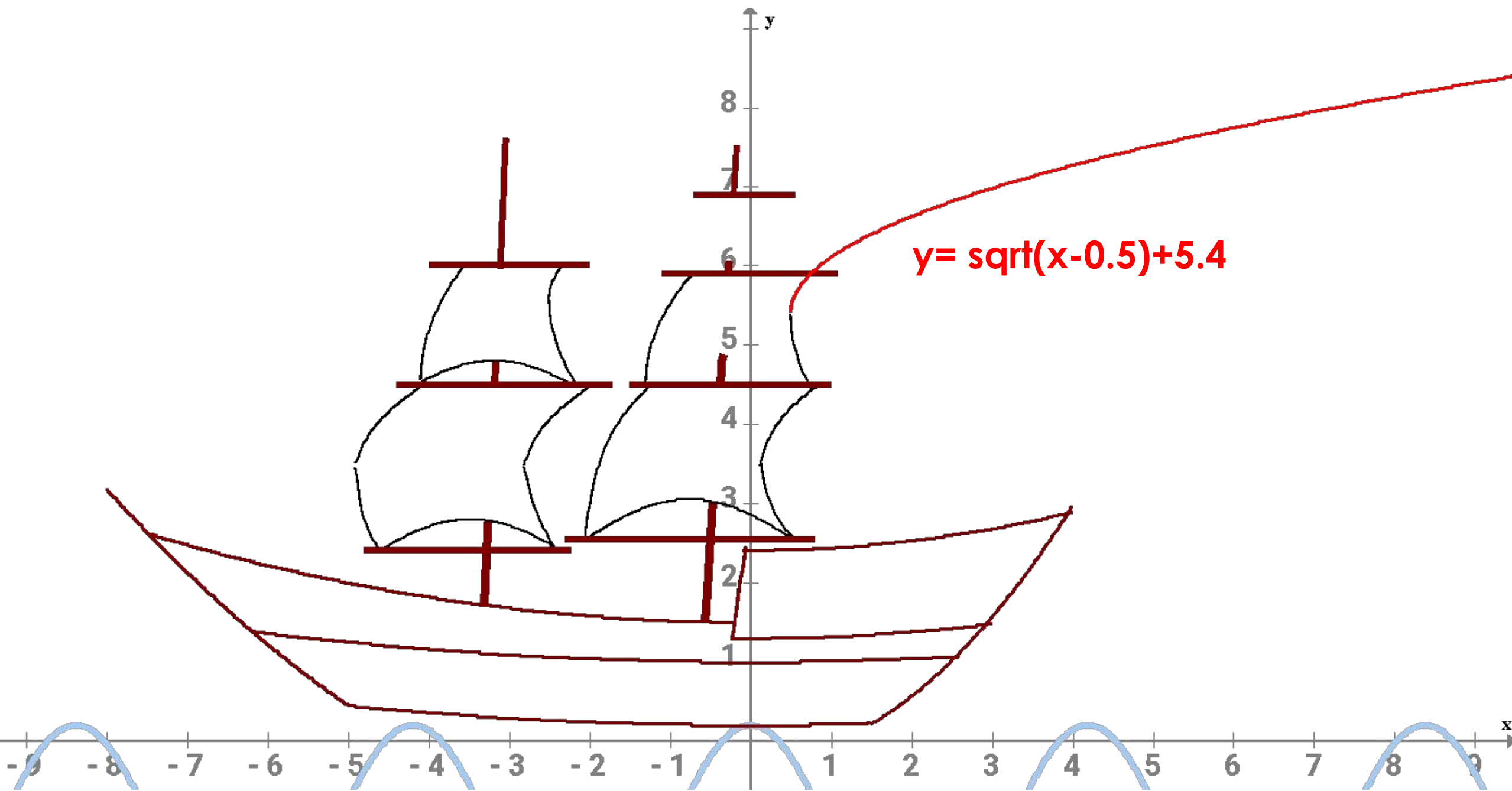

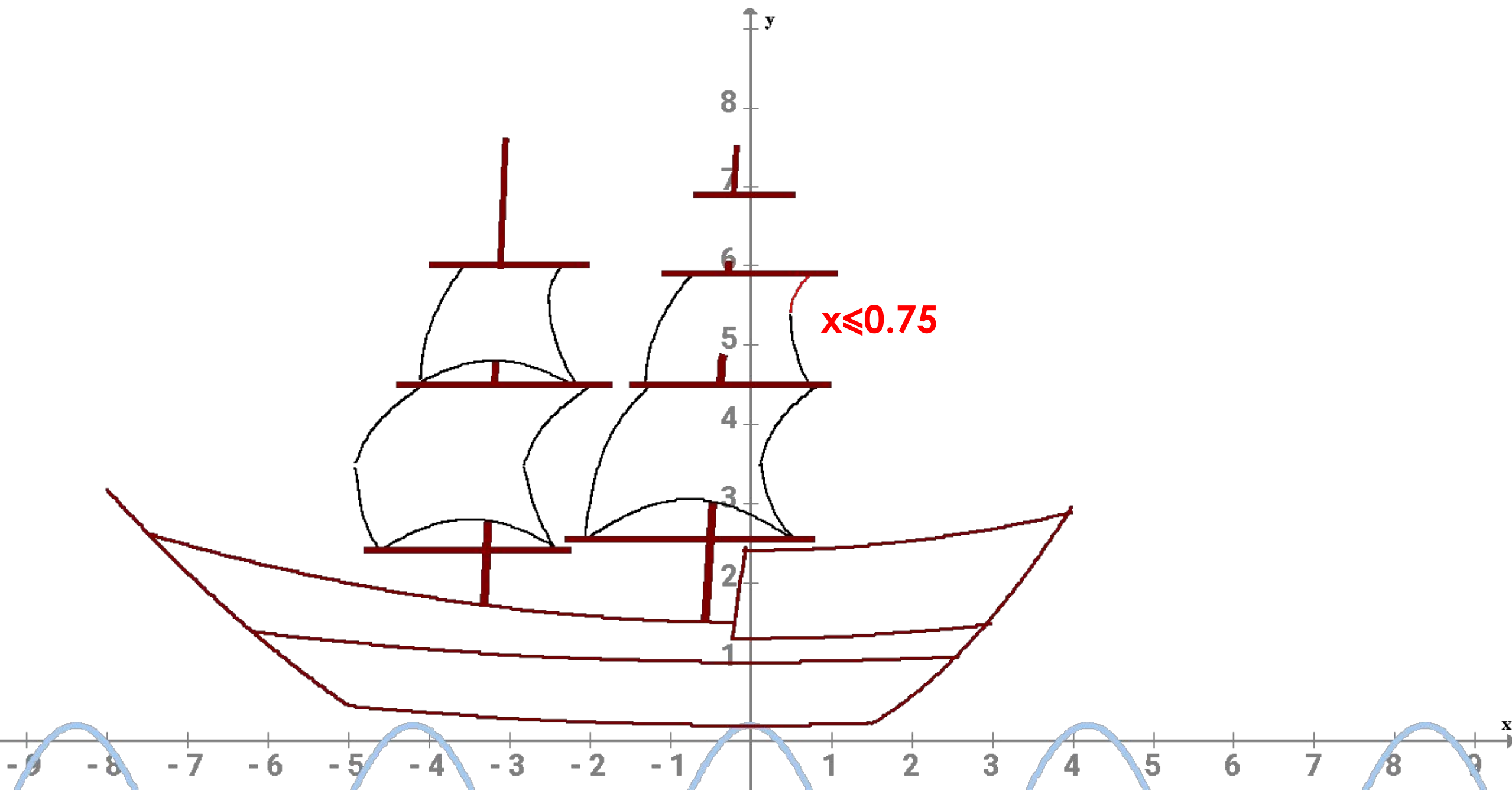

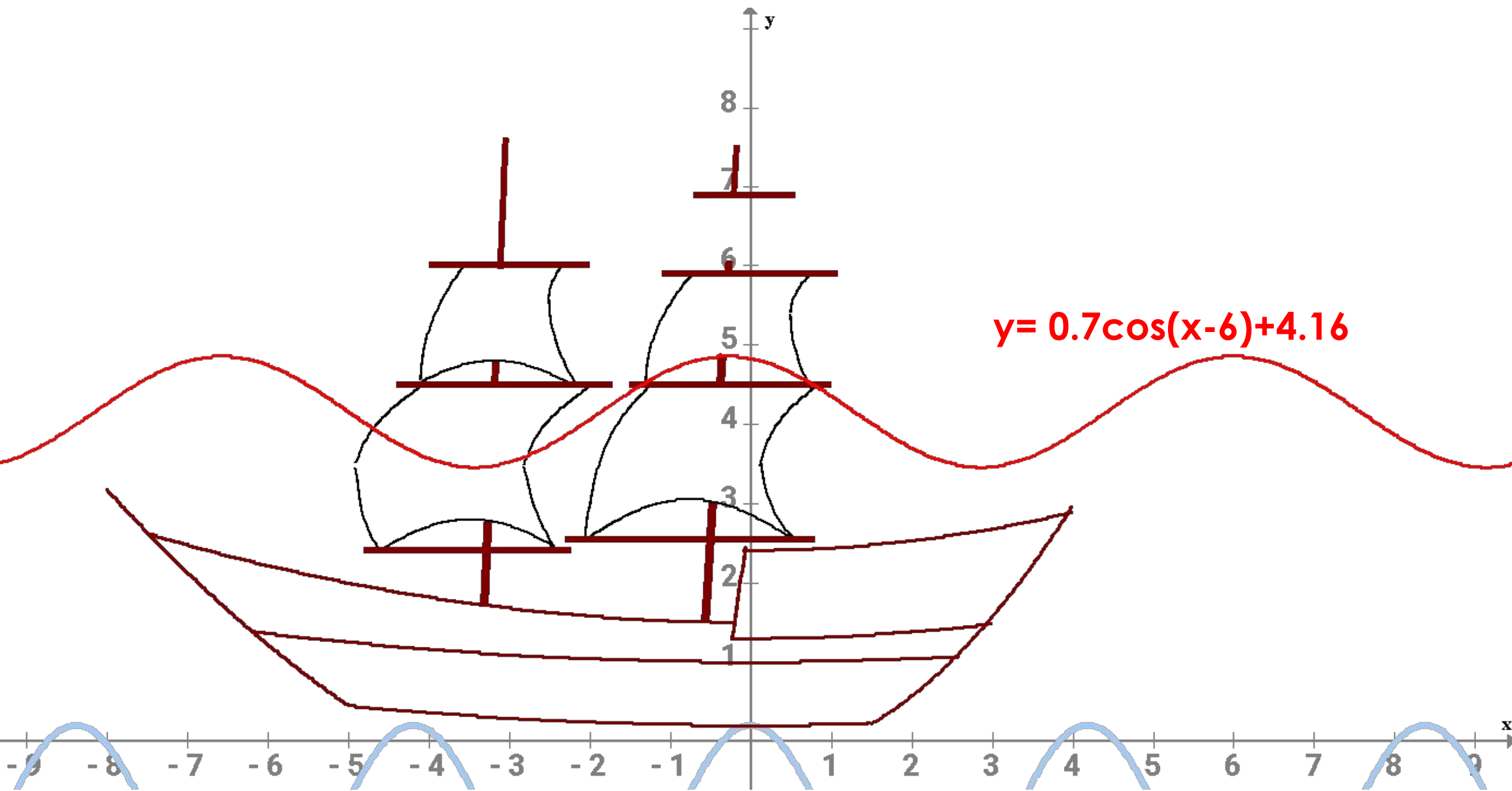

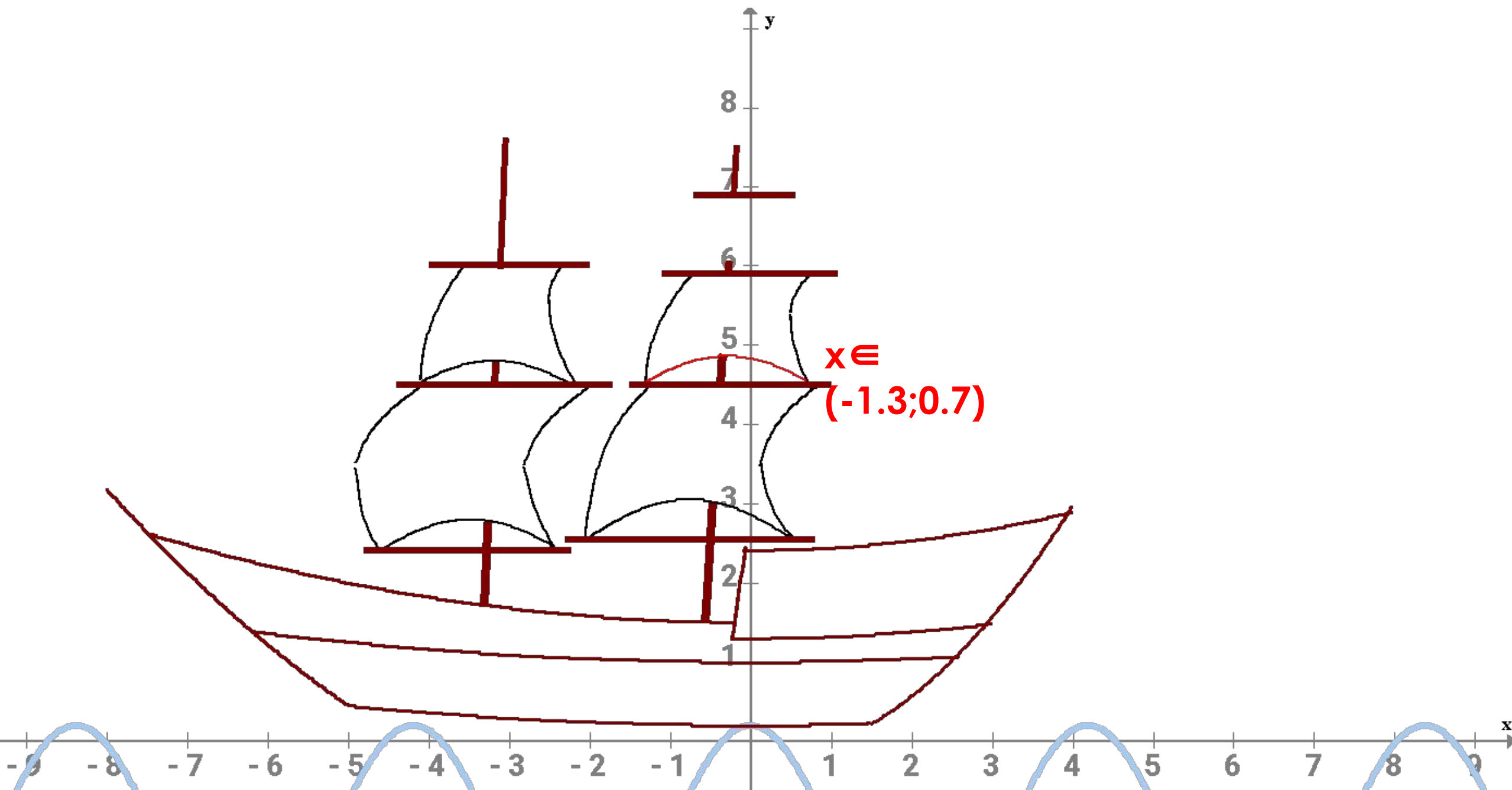

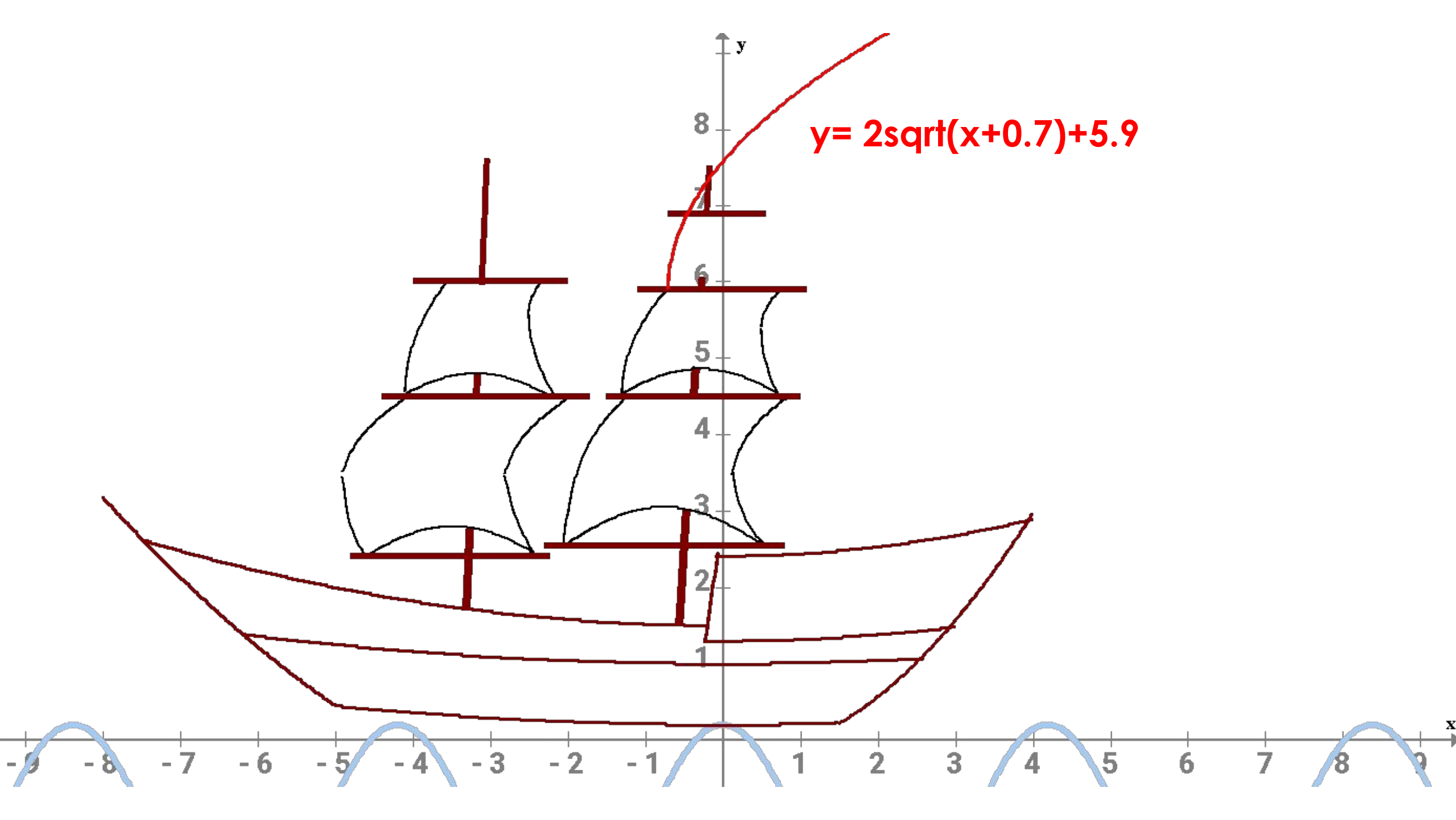

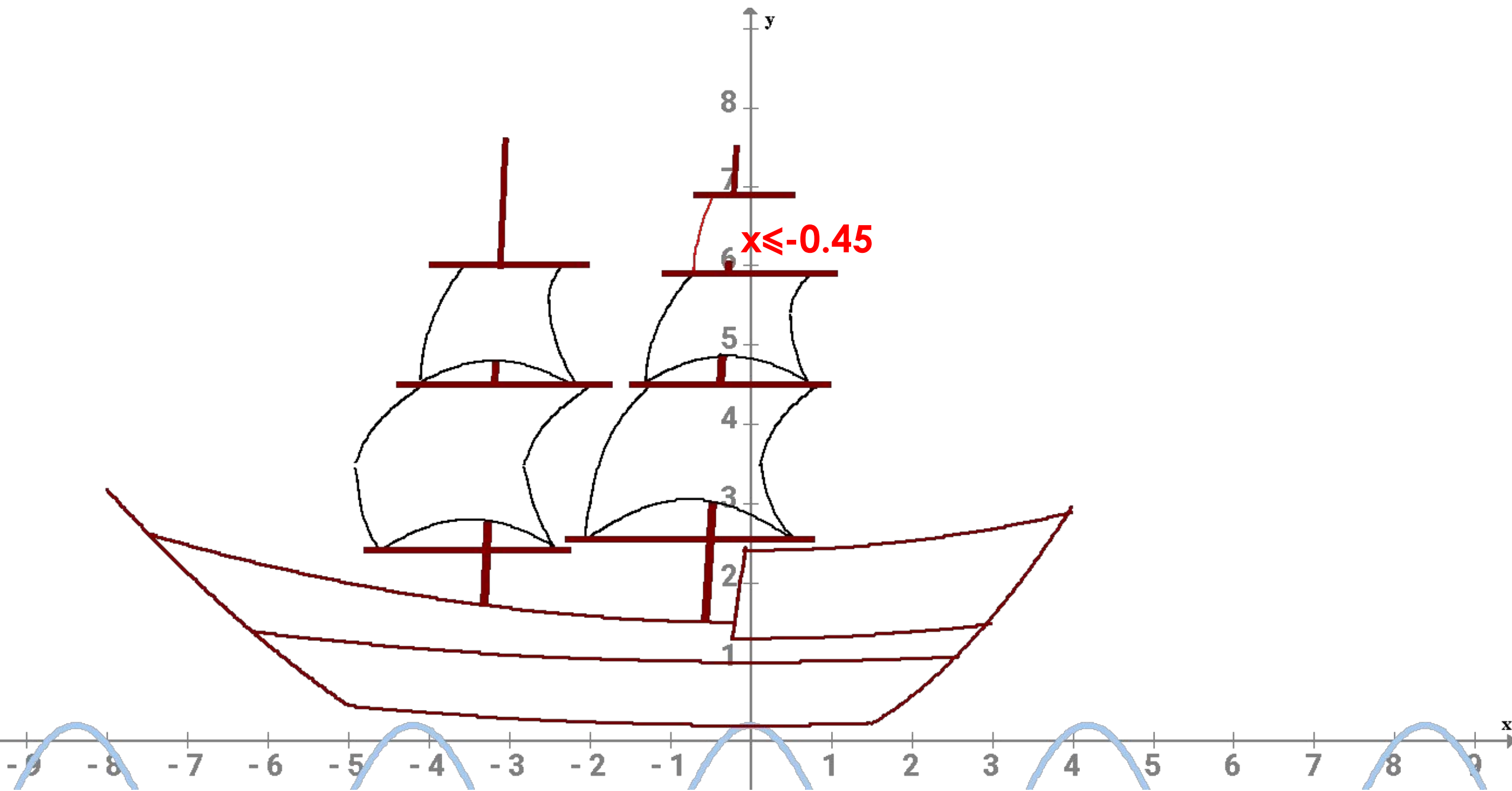

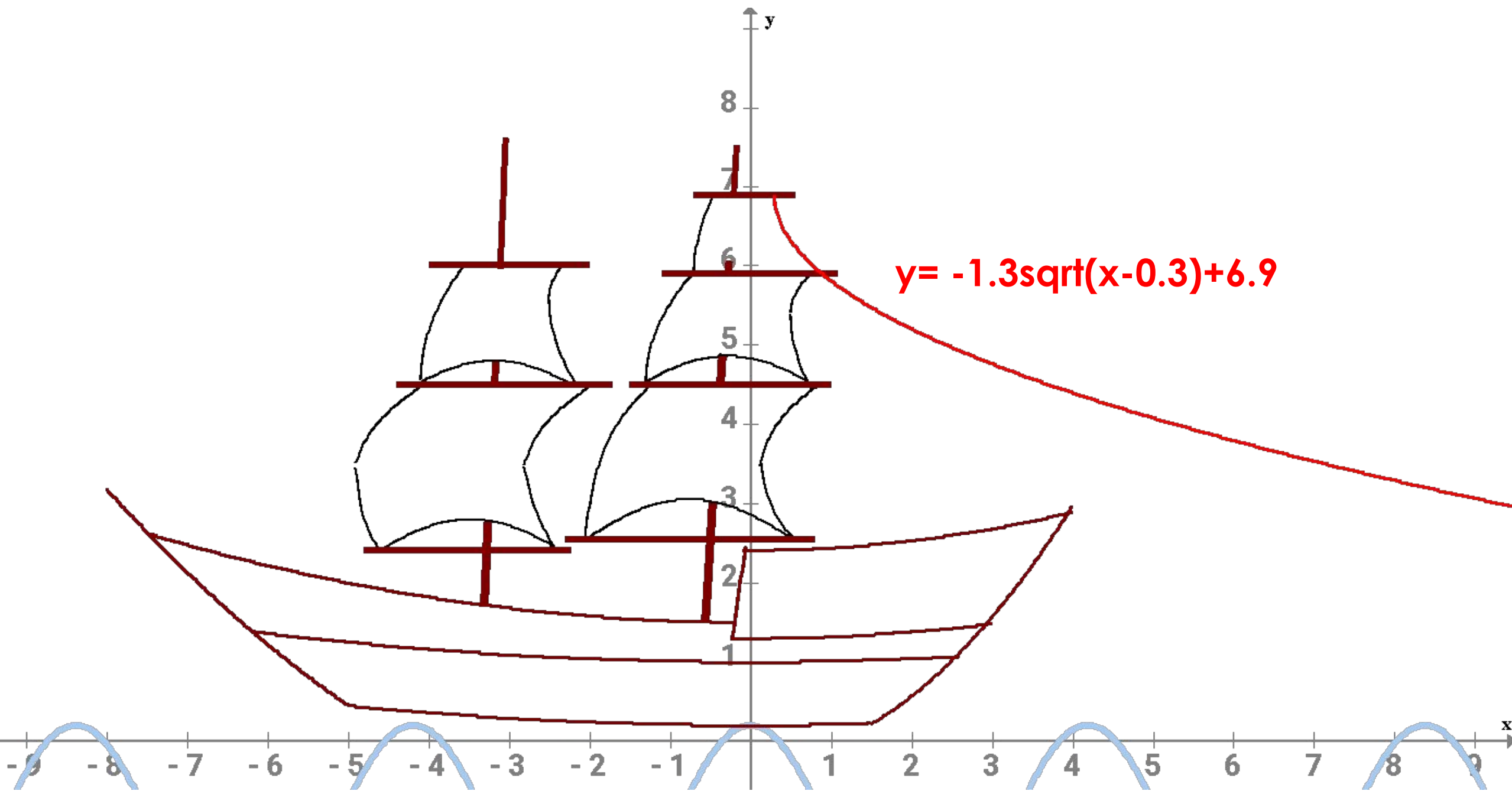

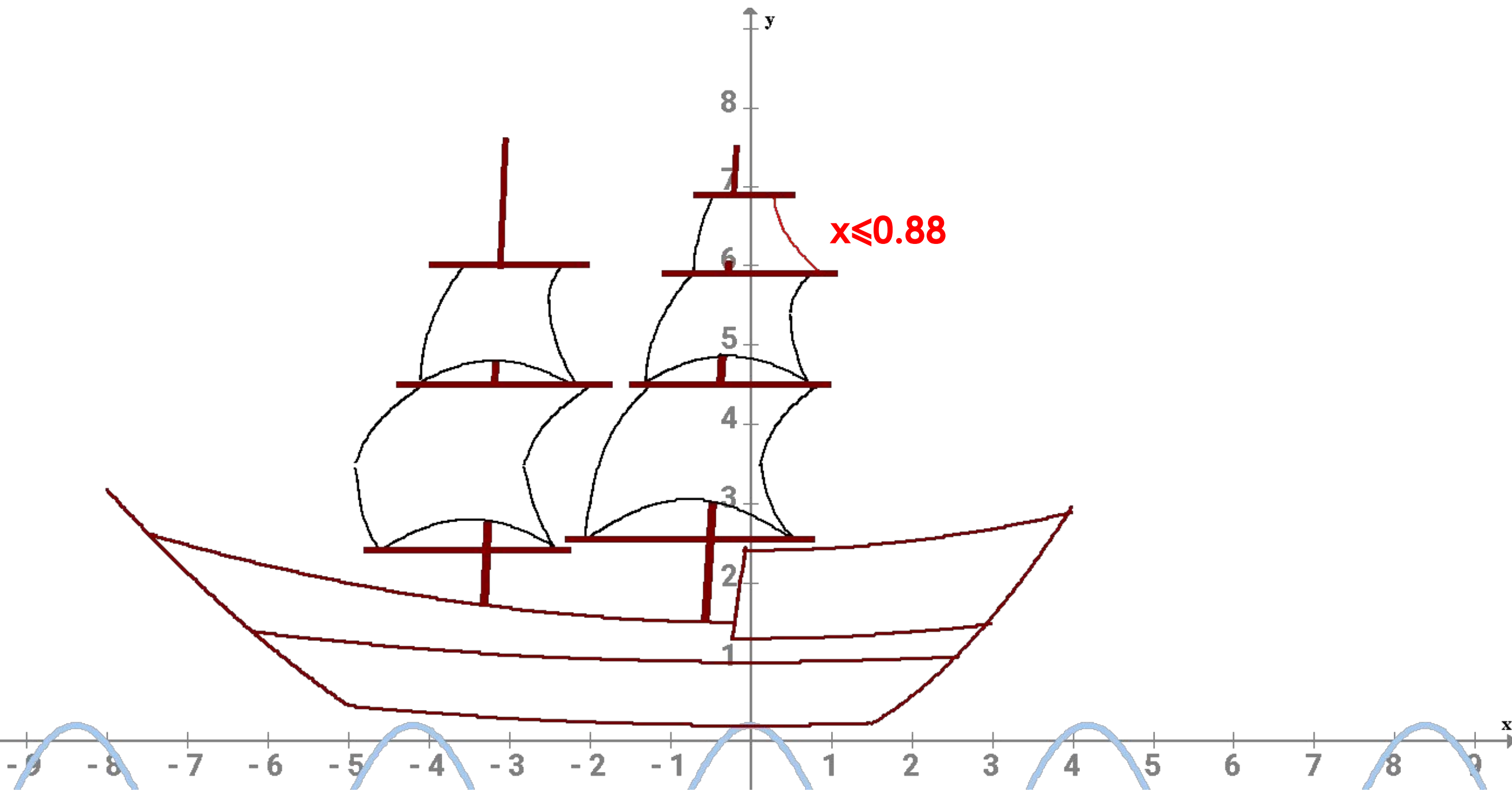

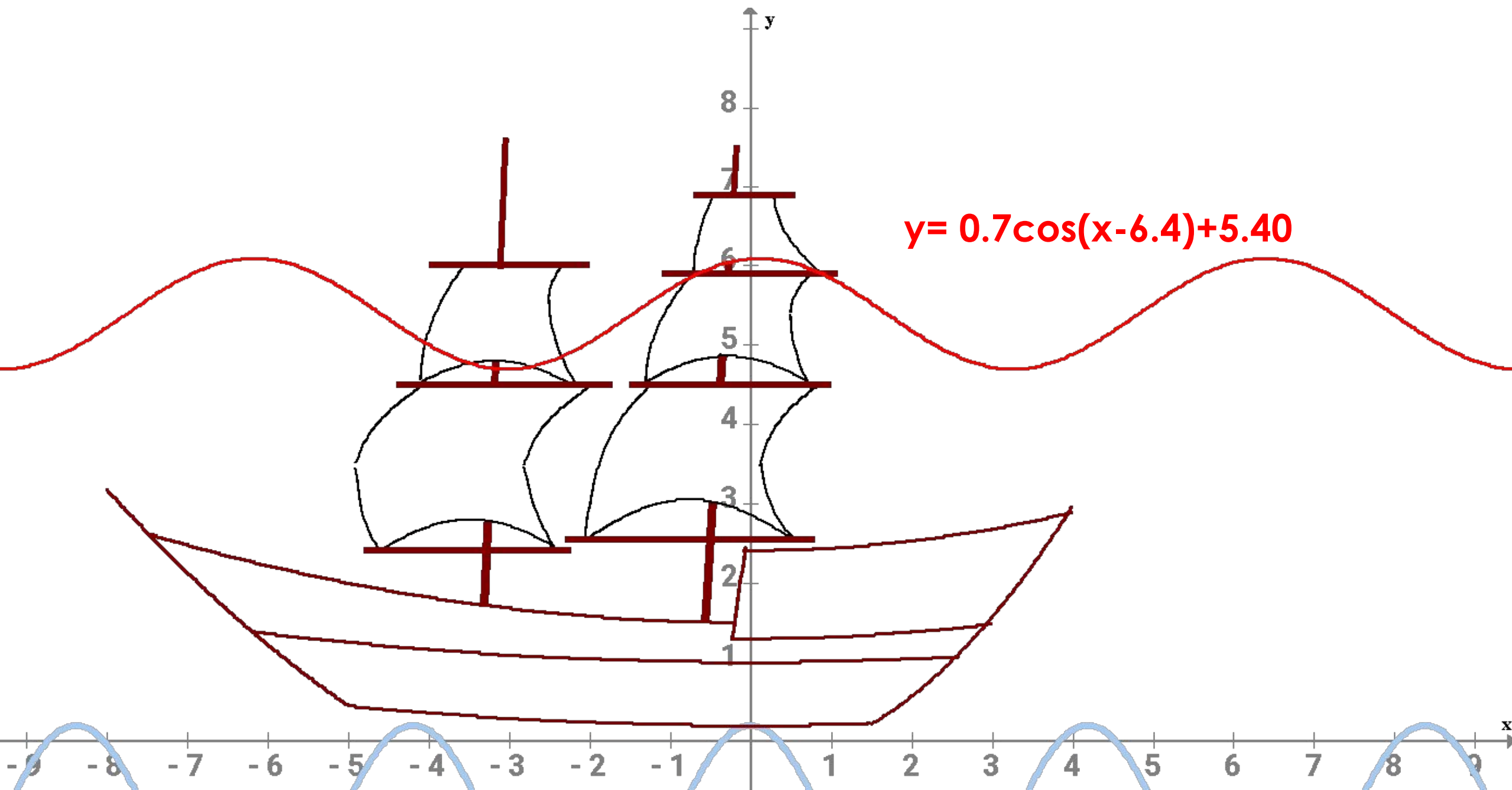

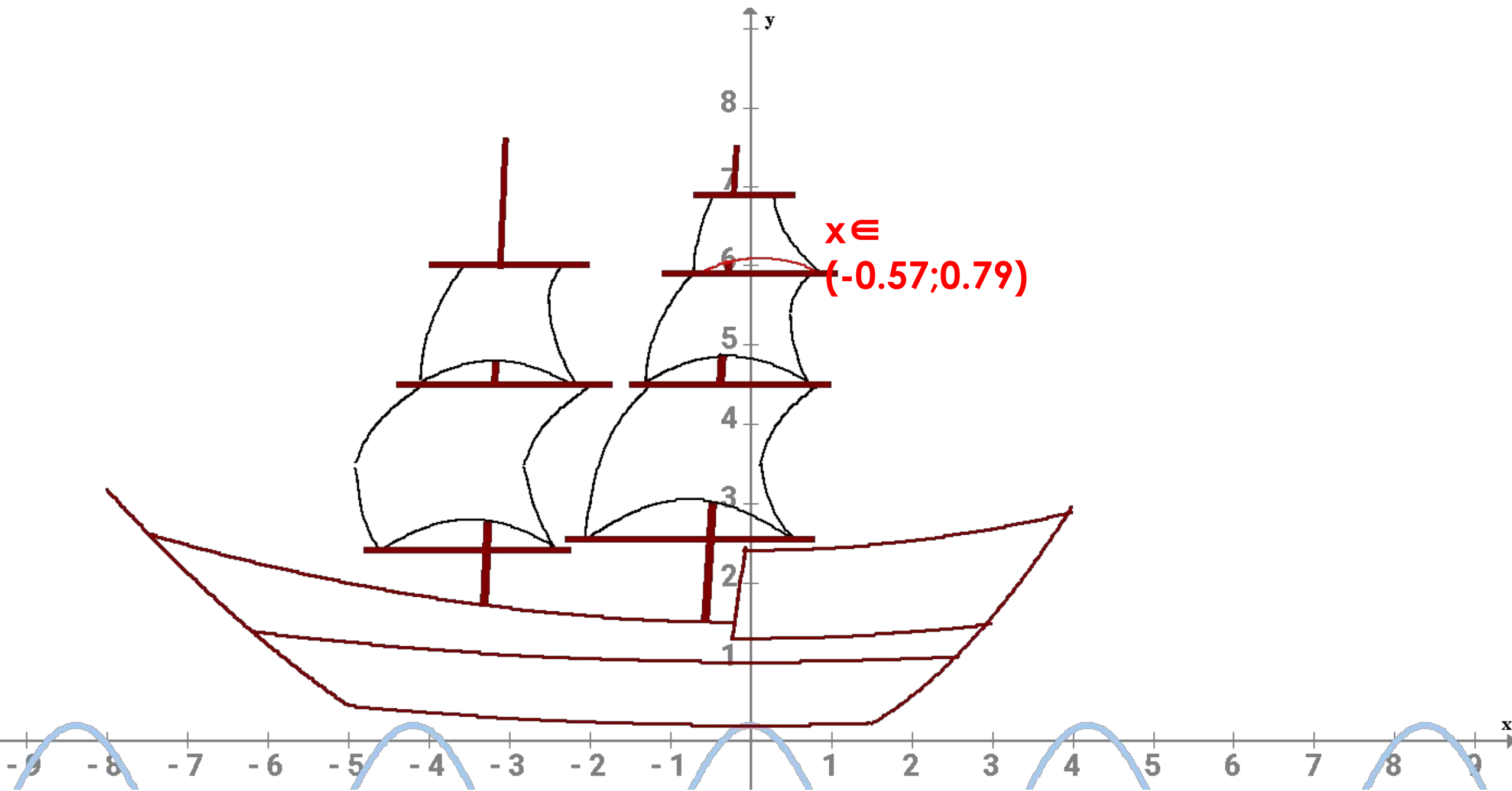

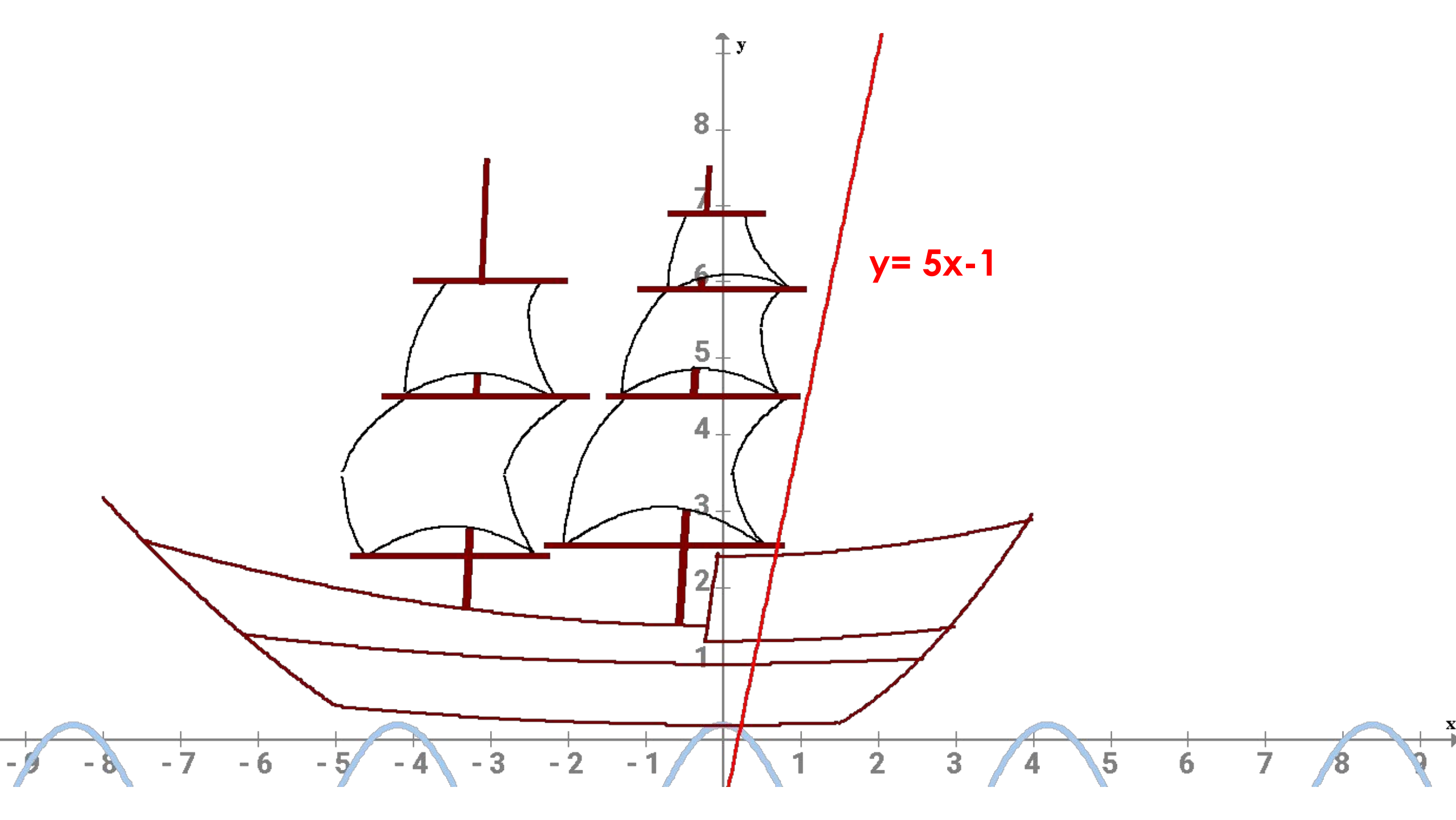

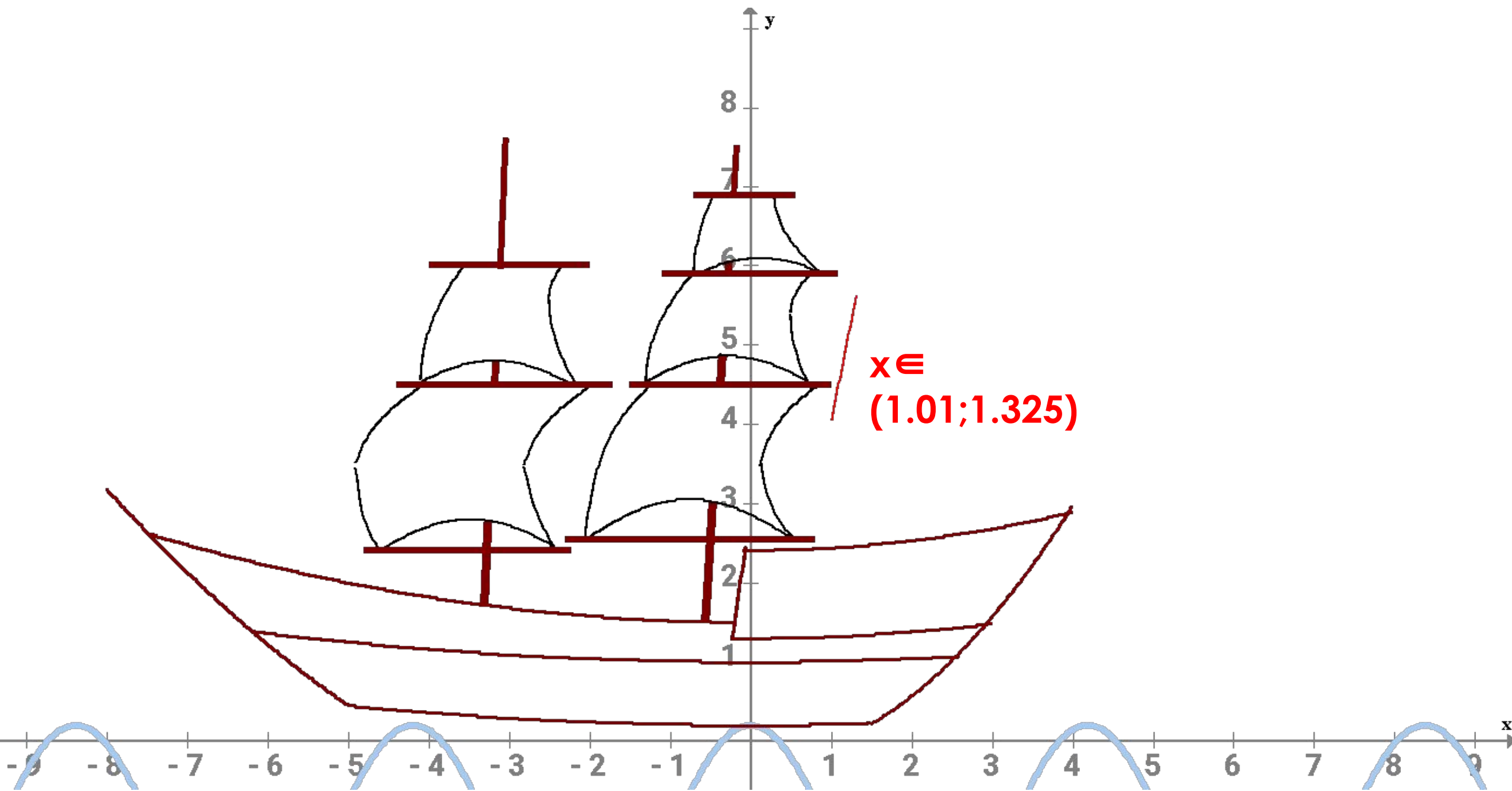

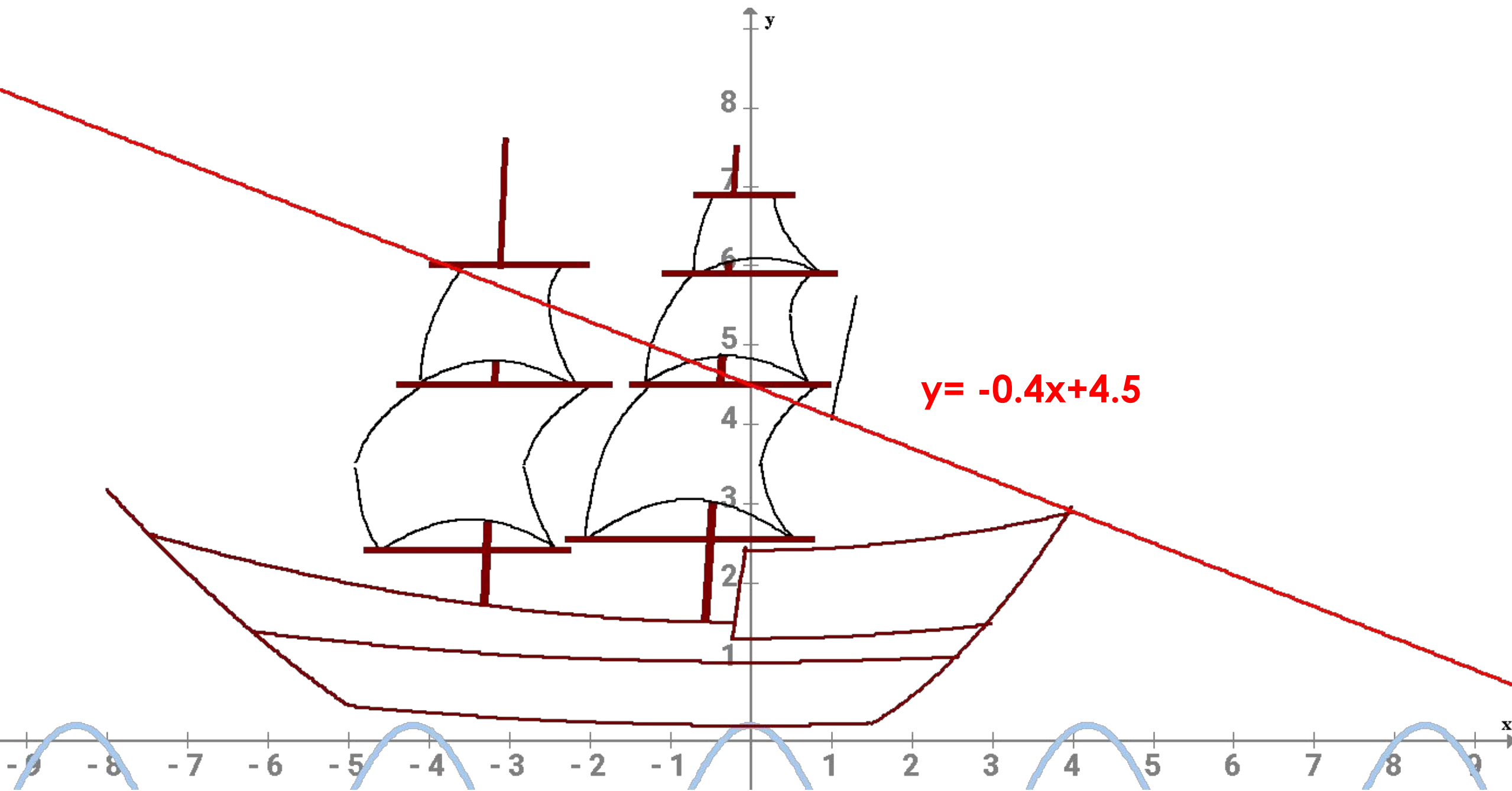

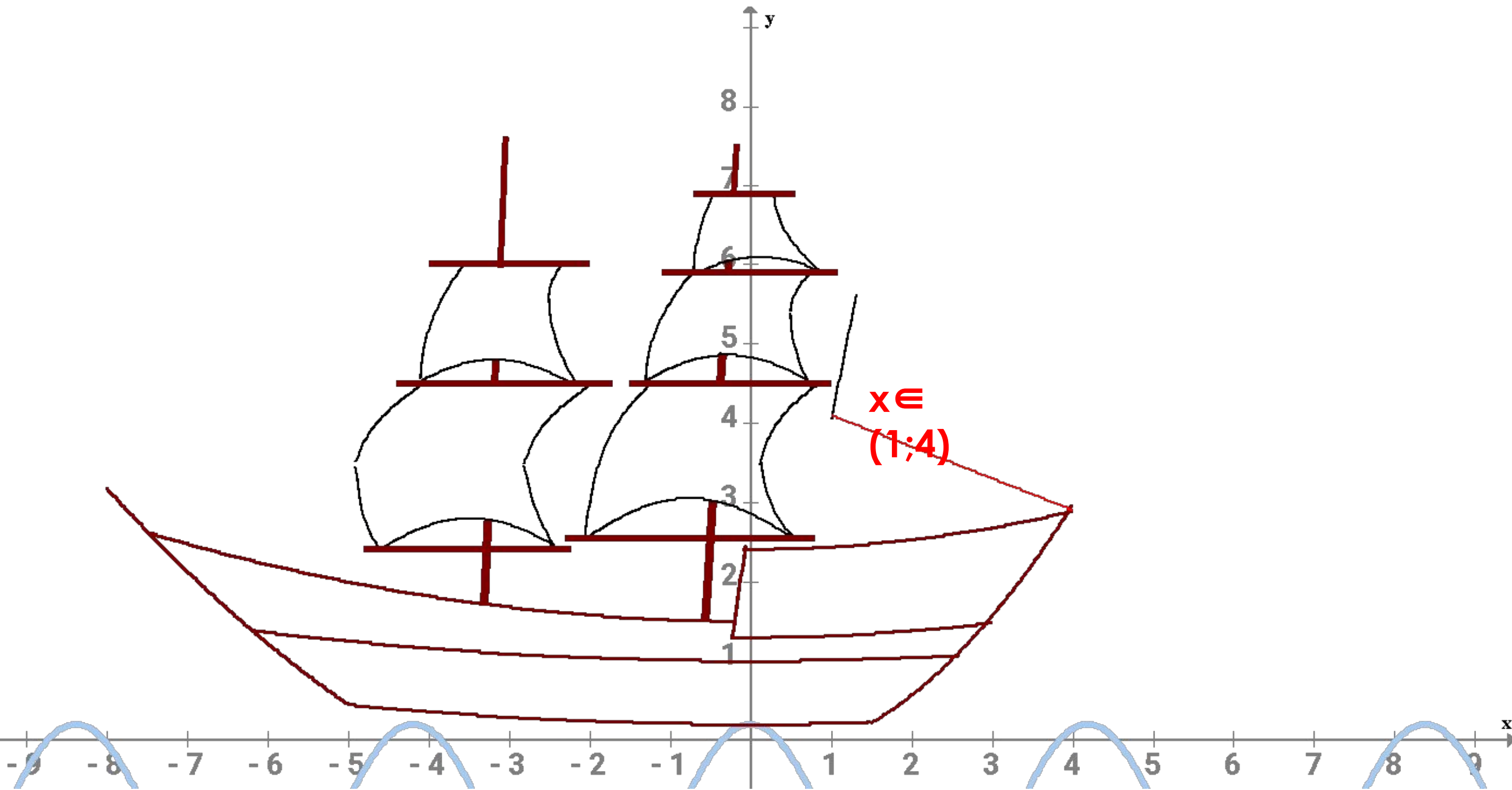

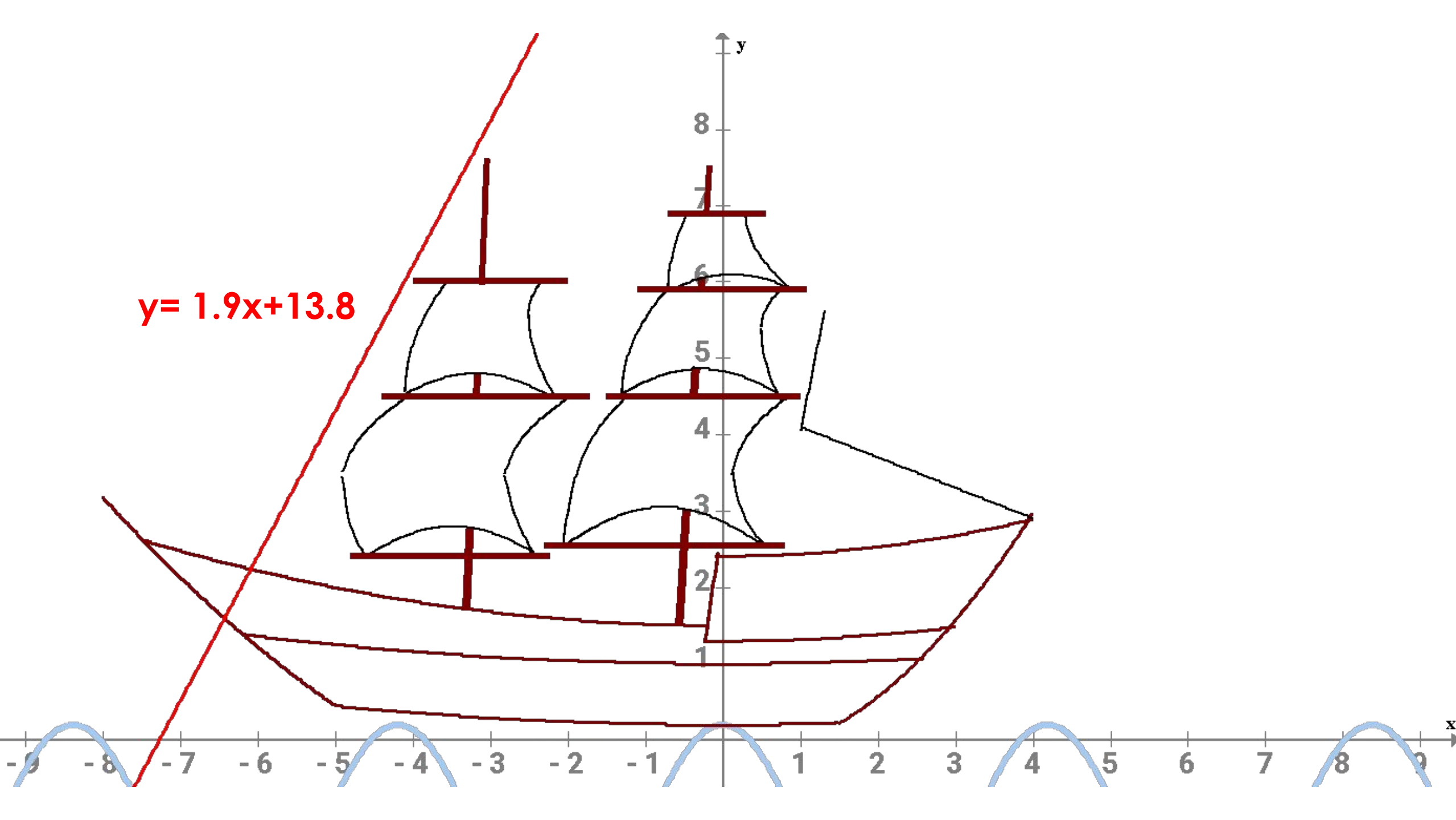

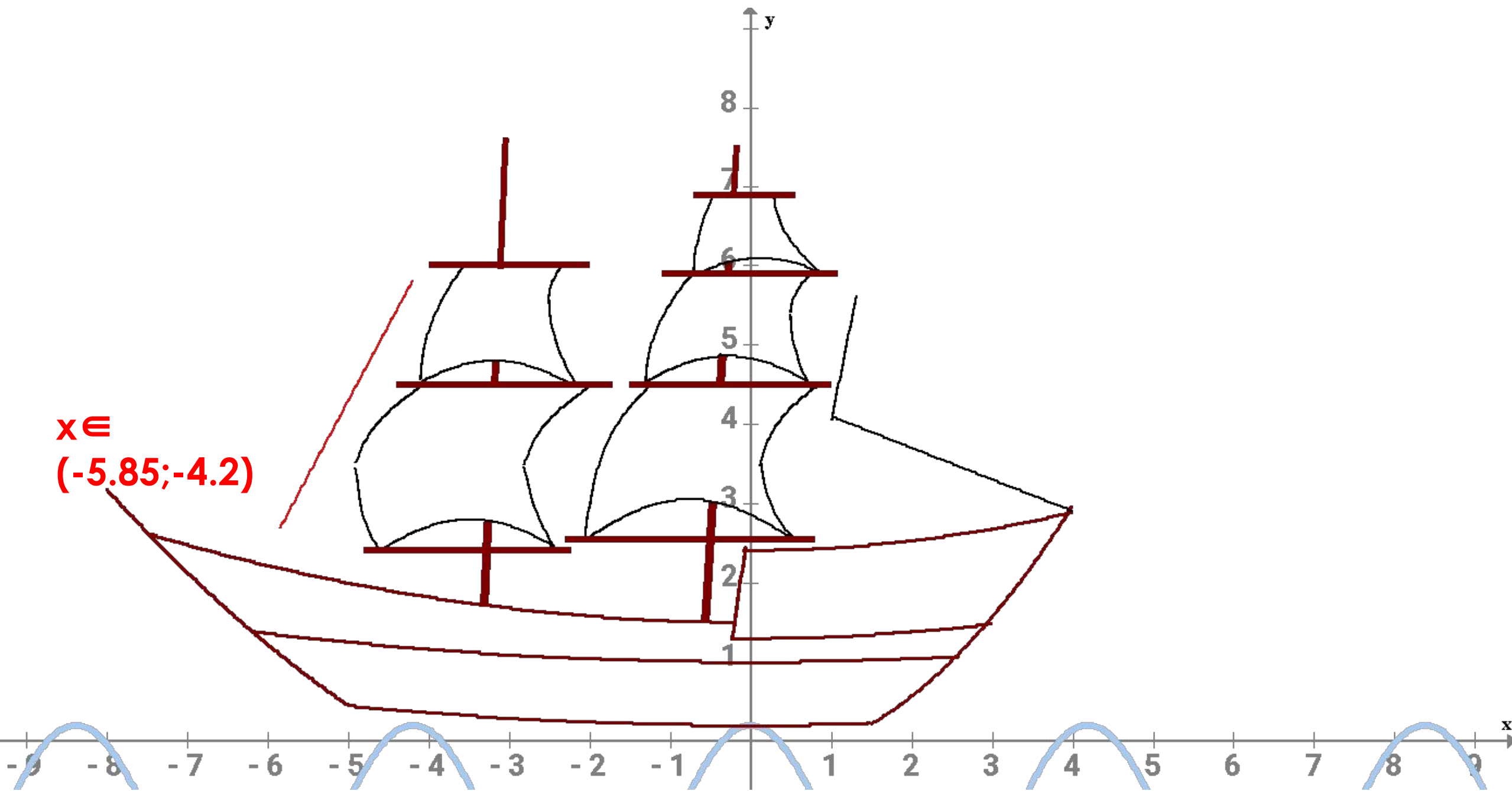

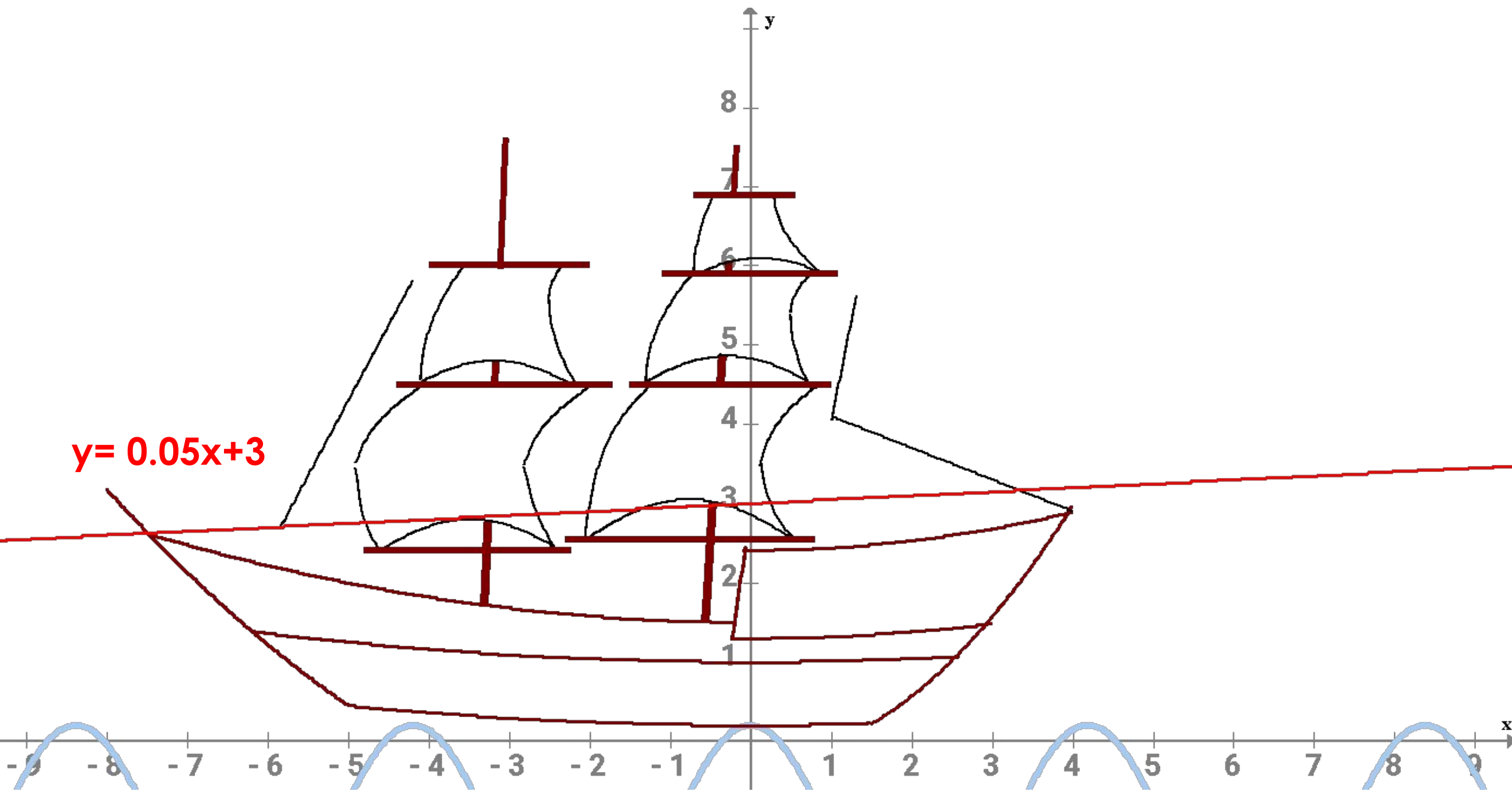

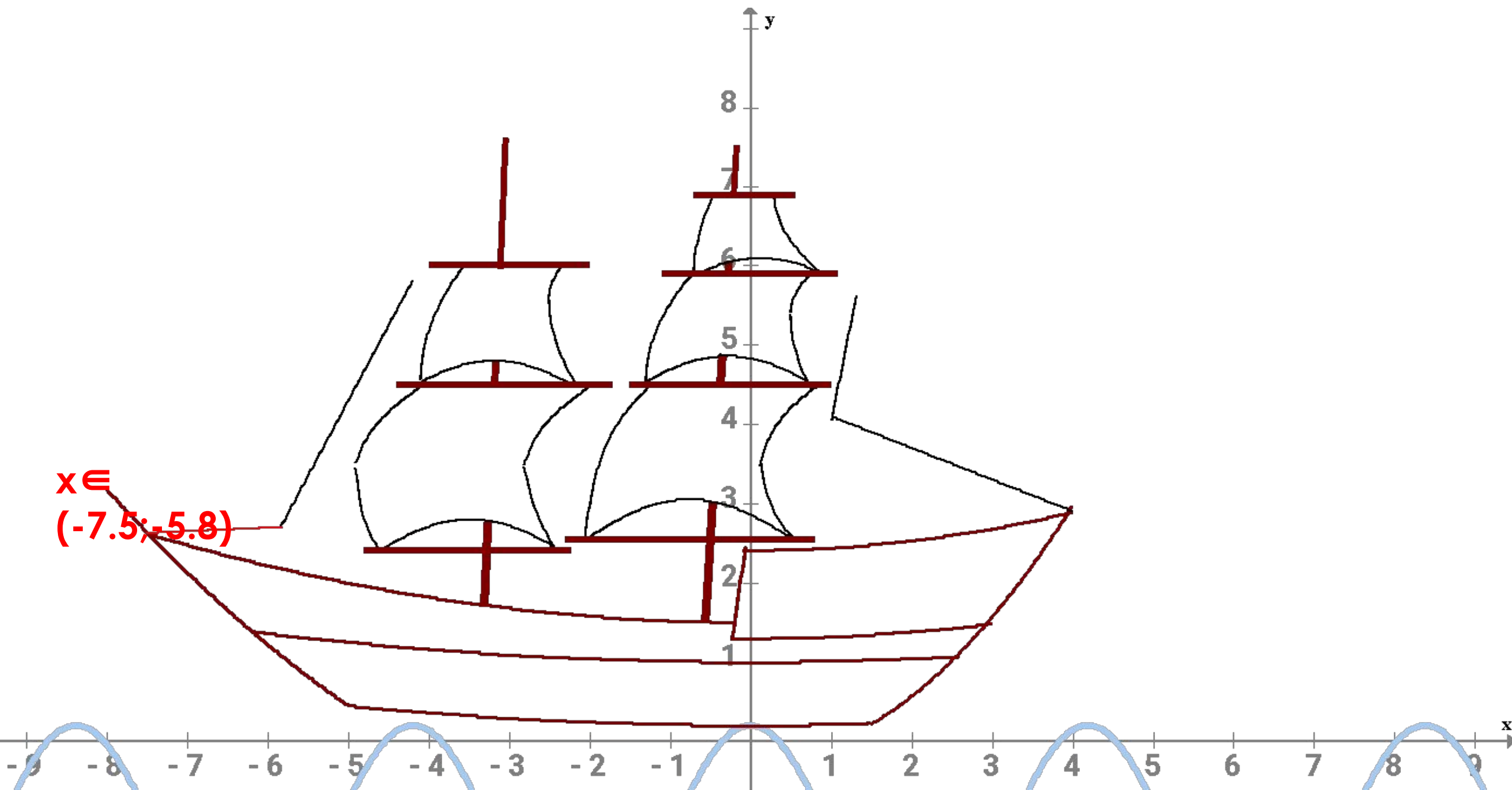

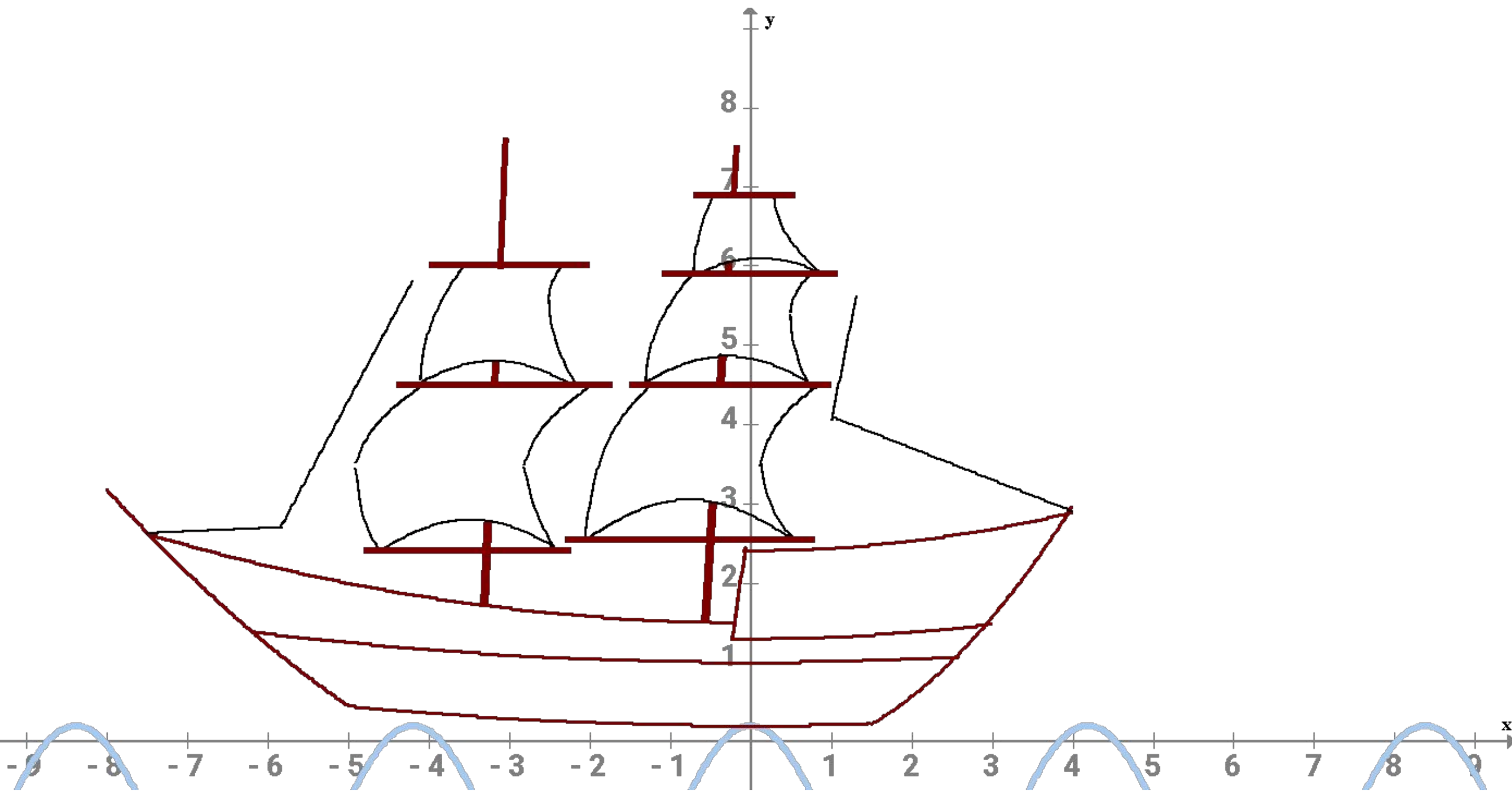

V этап

- «Завершение»

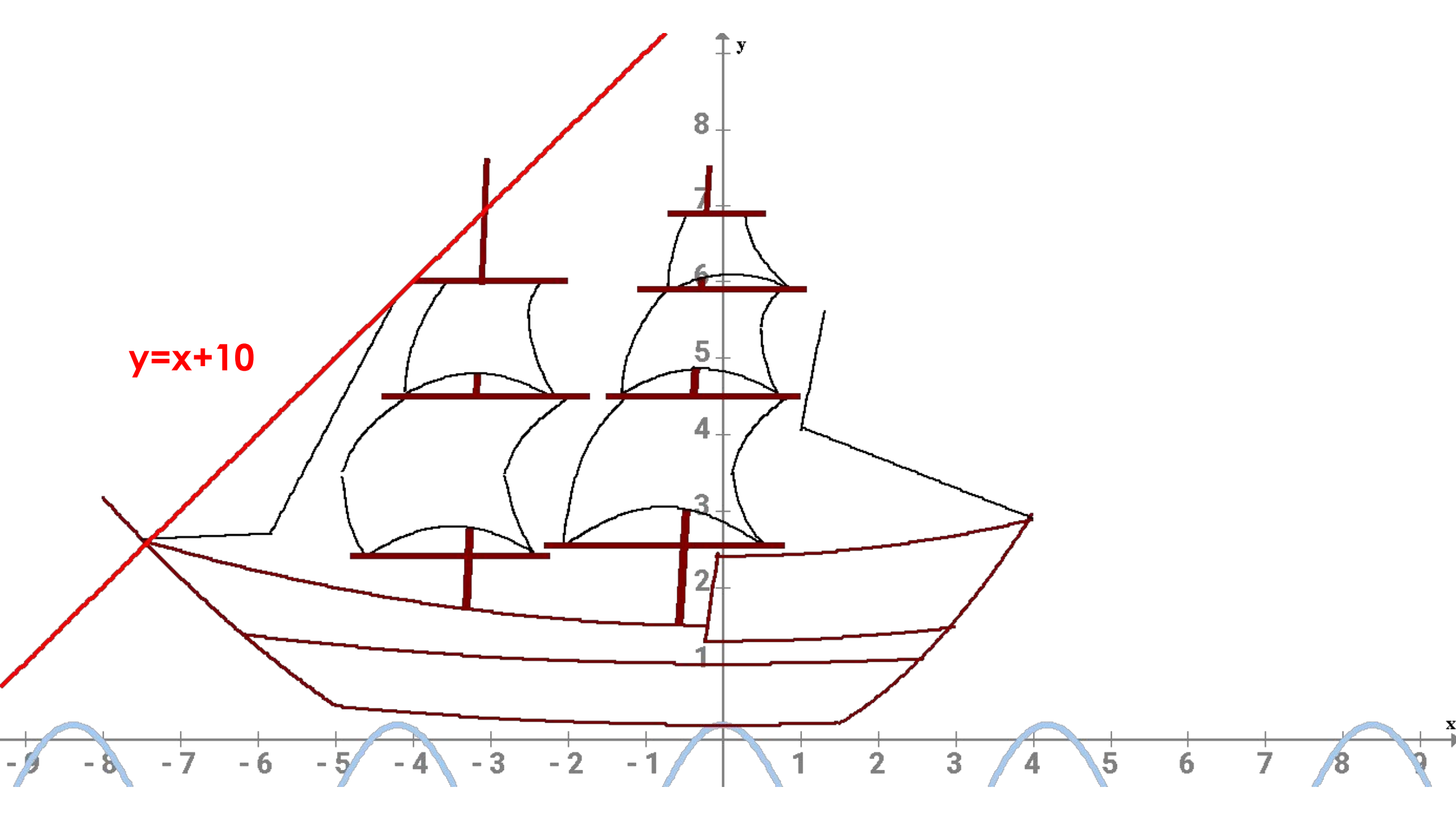

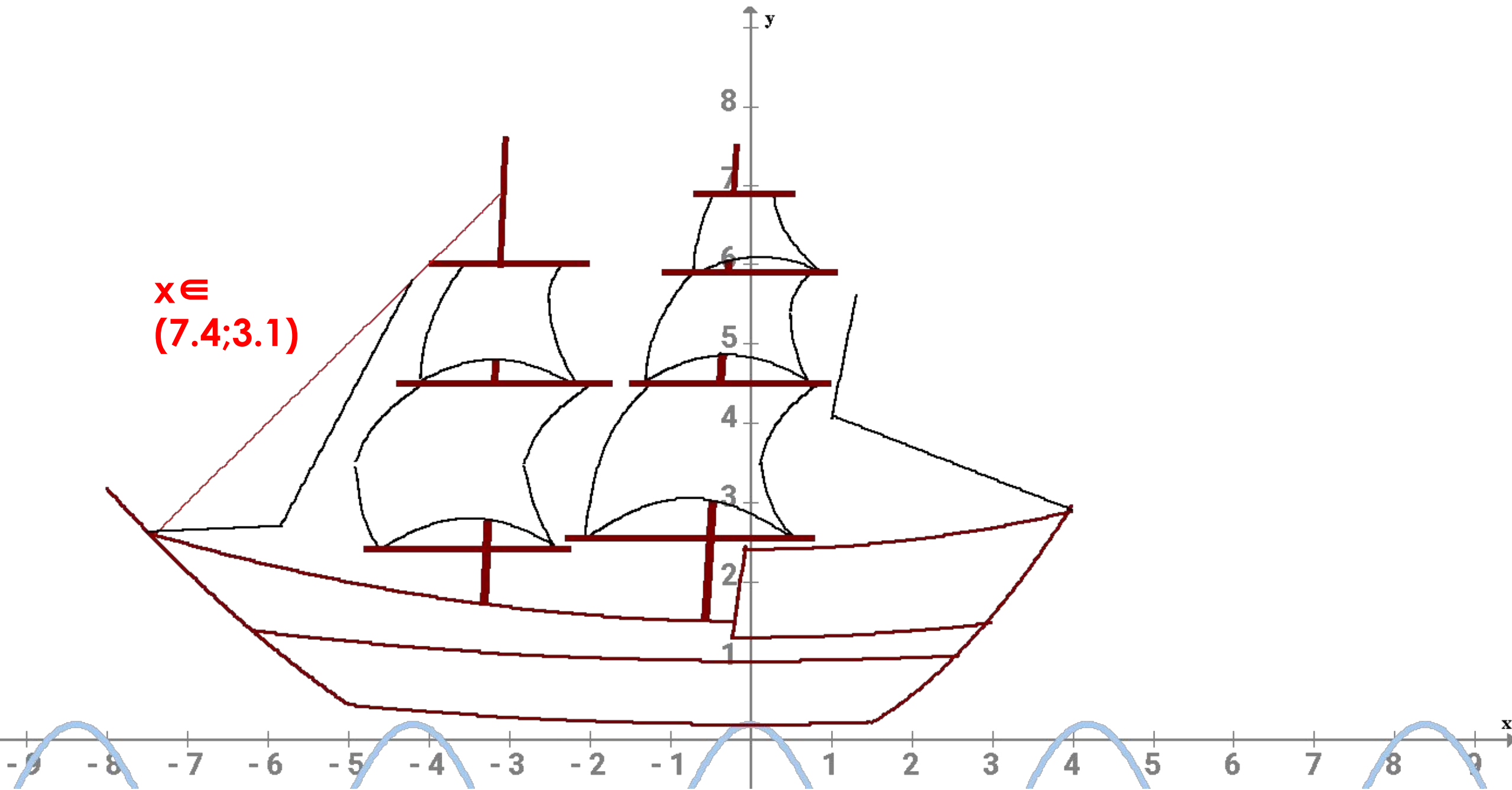

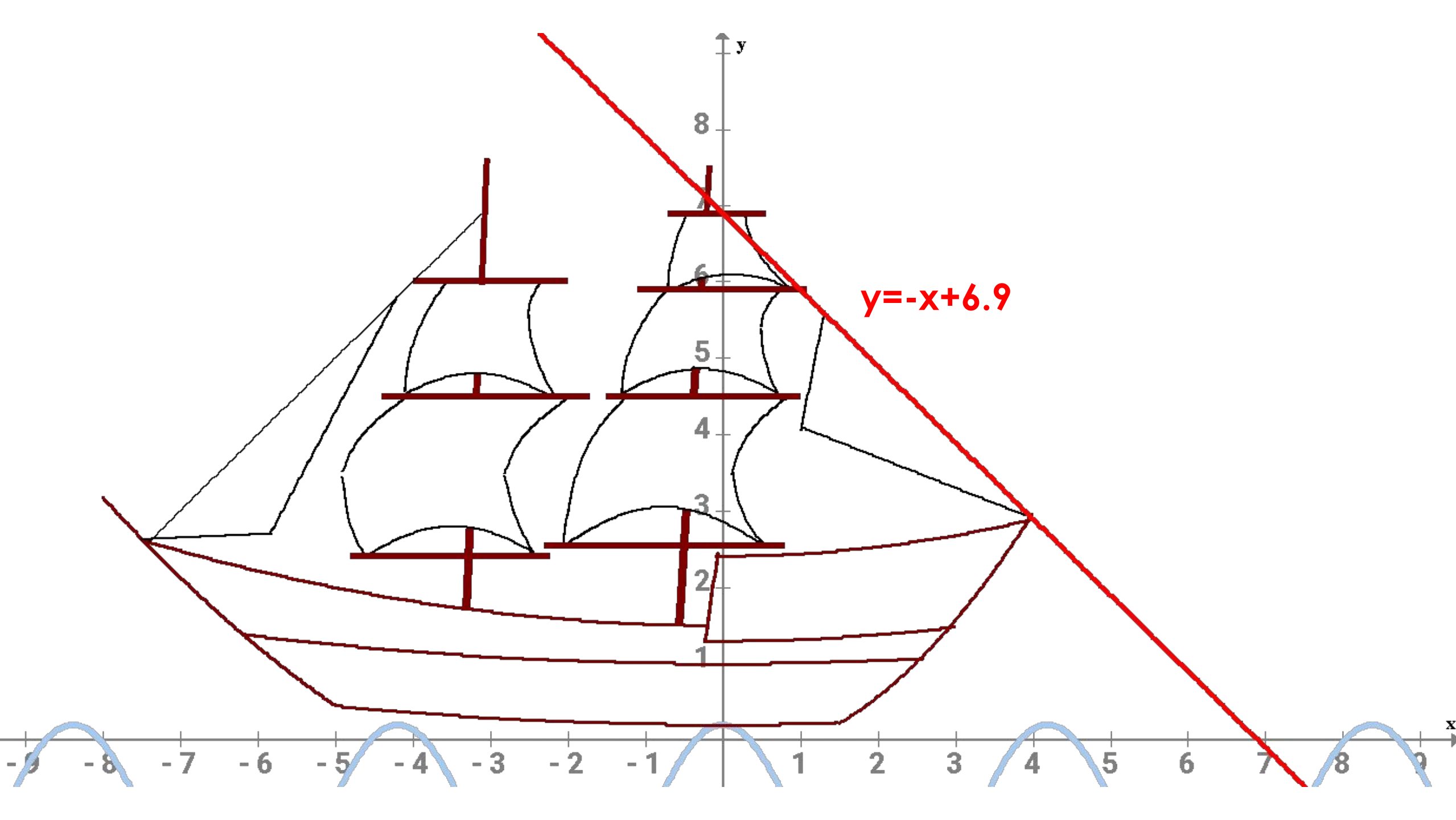

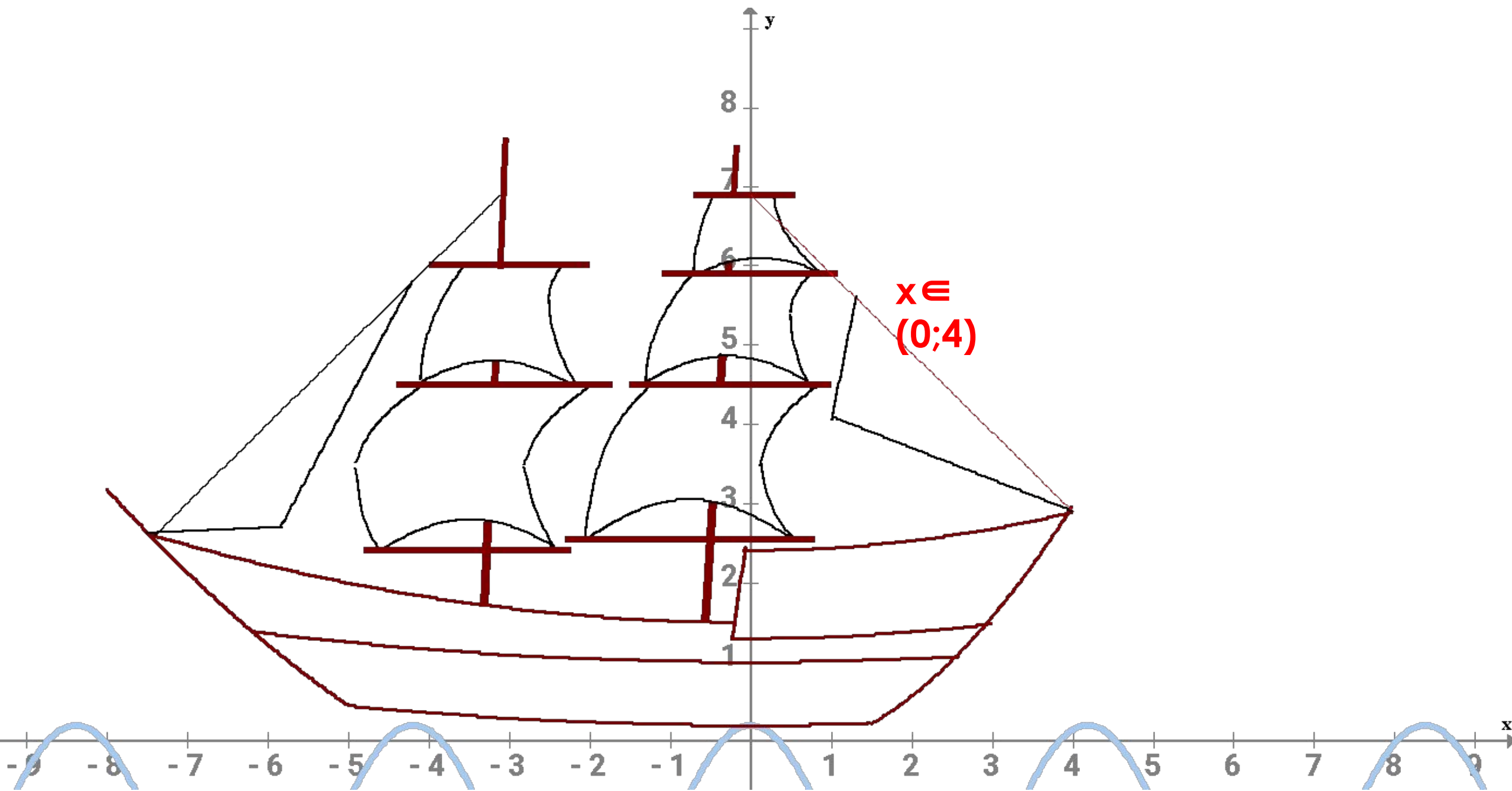

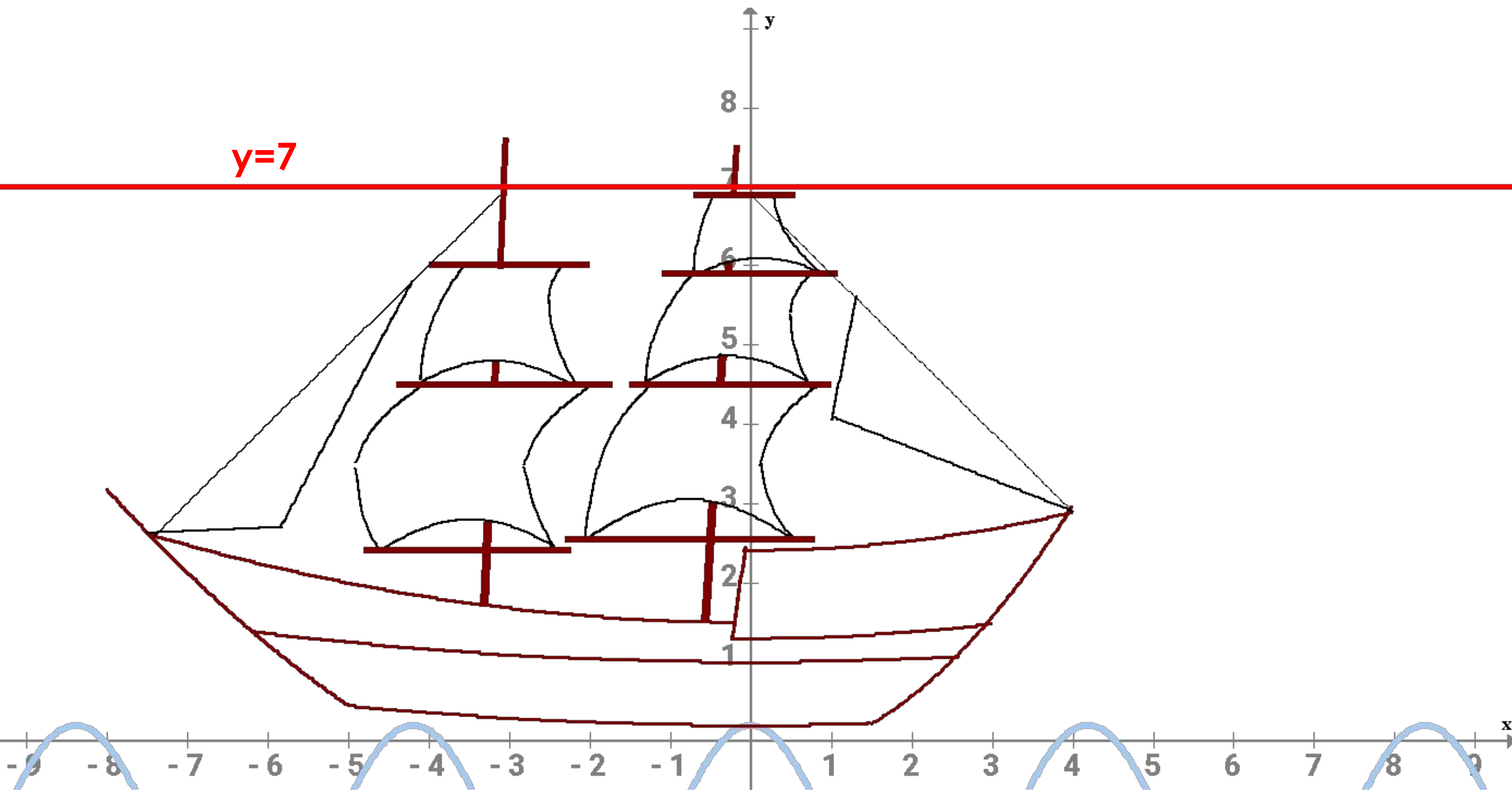

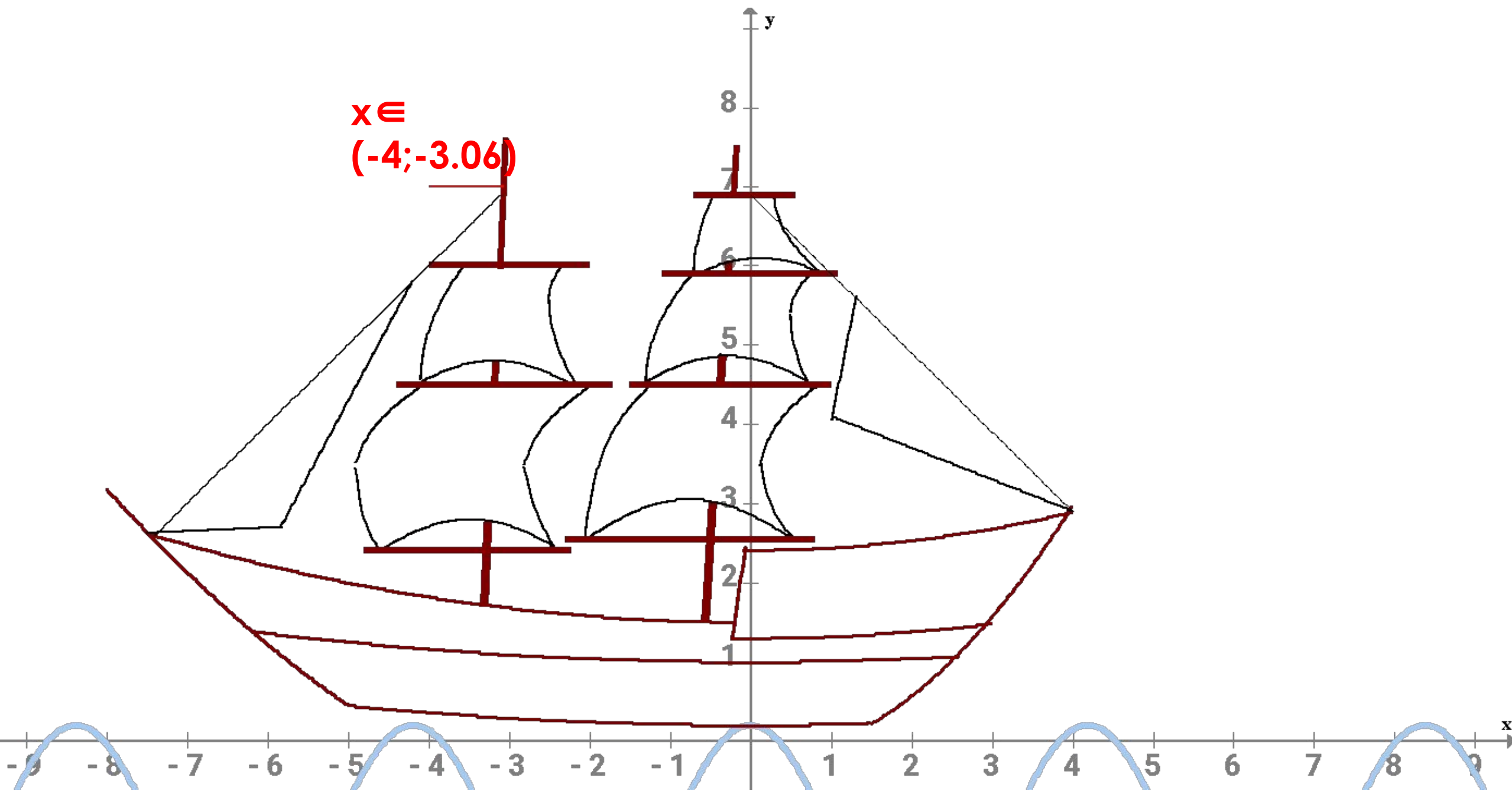

$y=7.5$

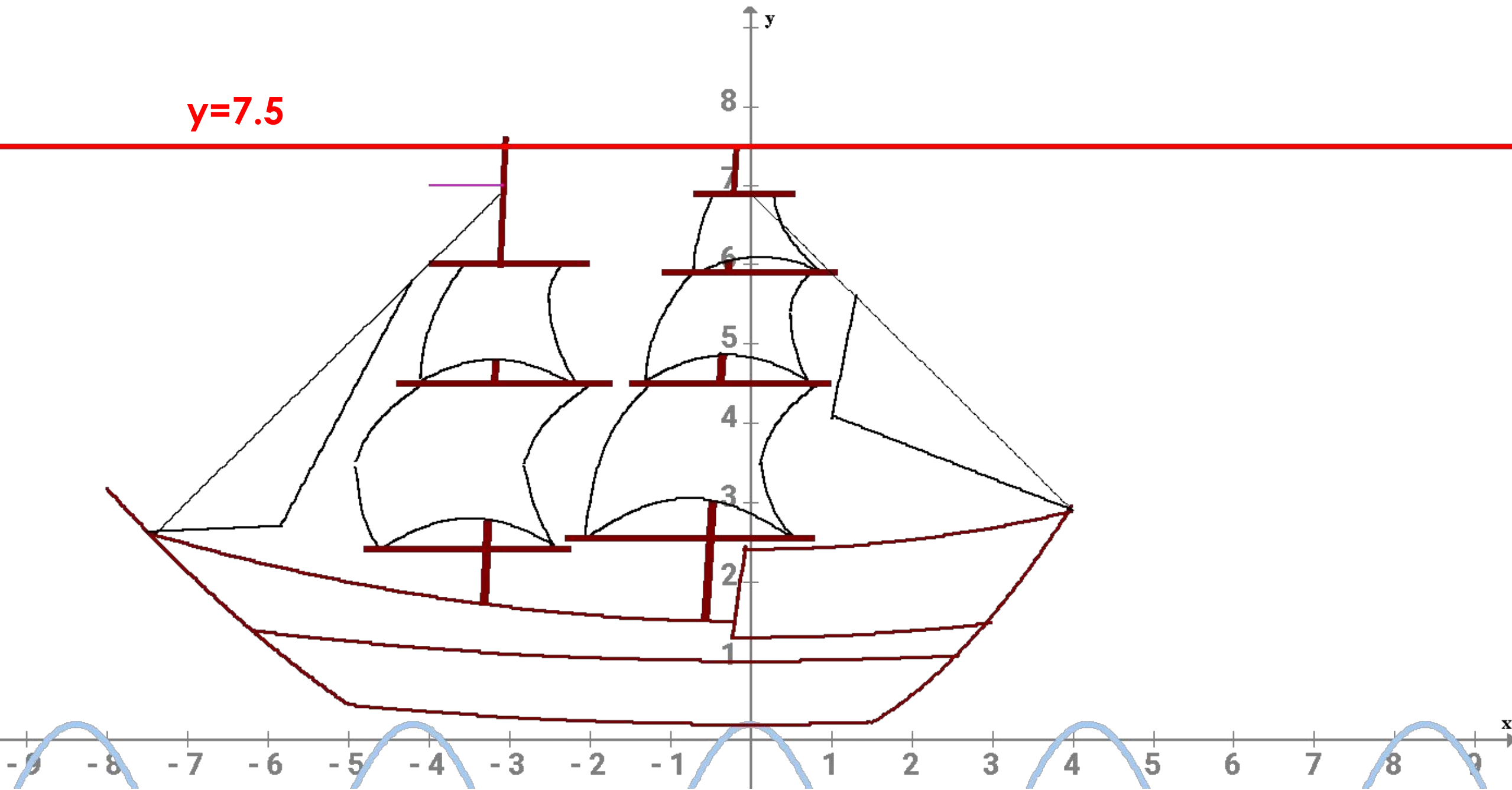

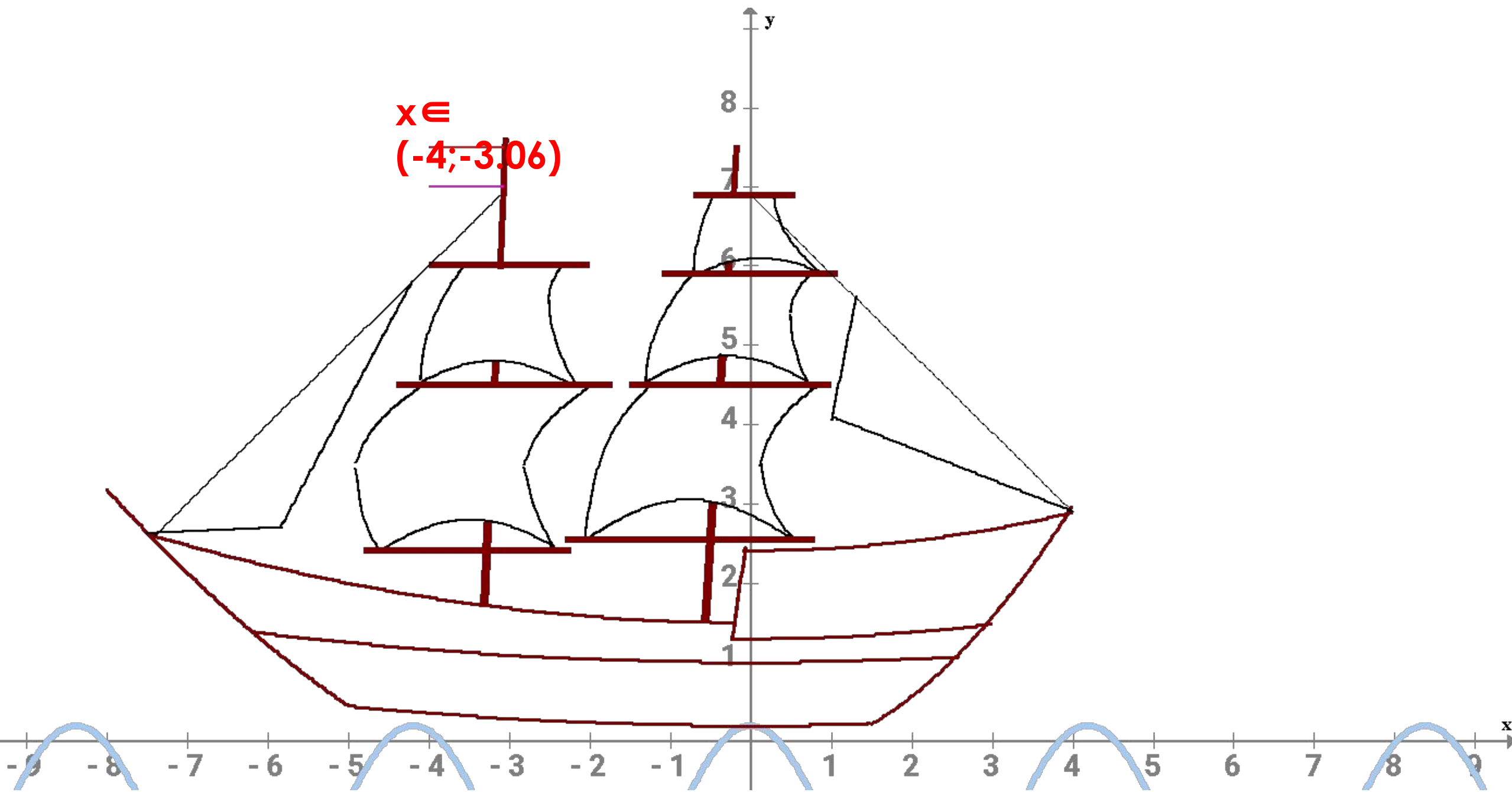

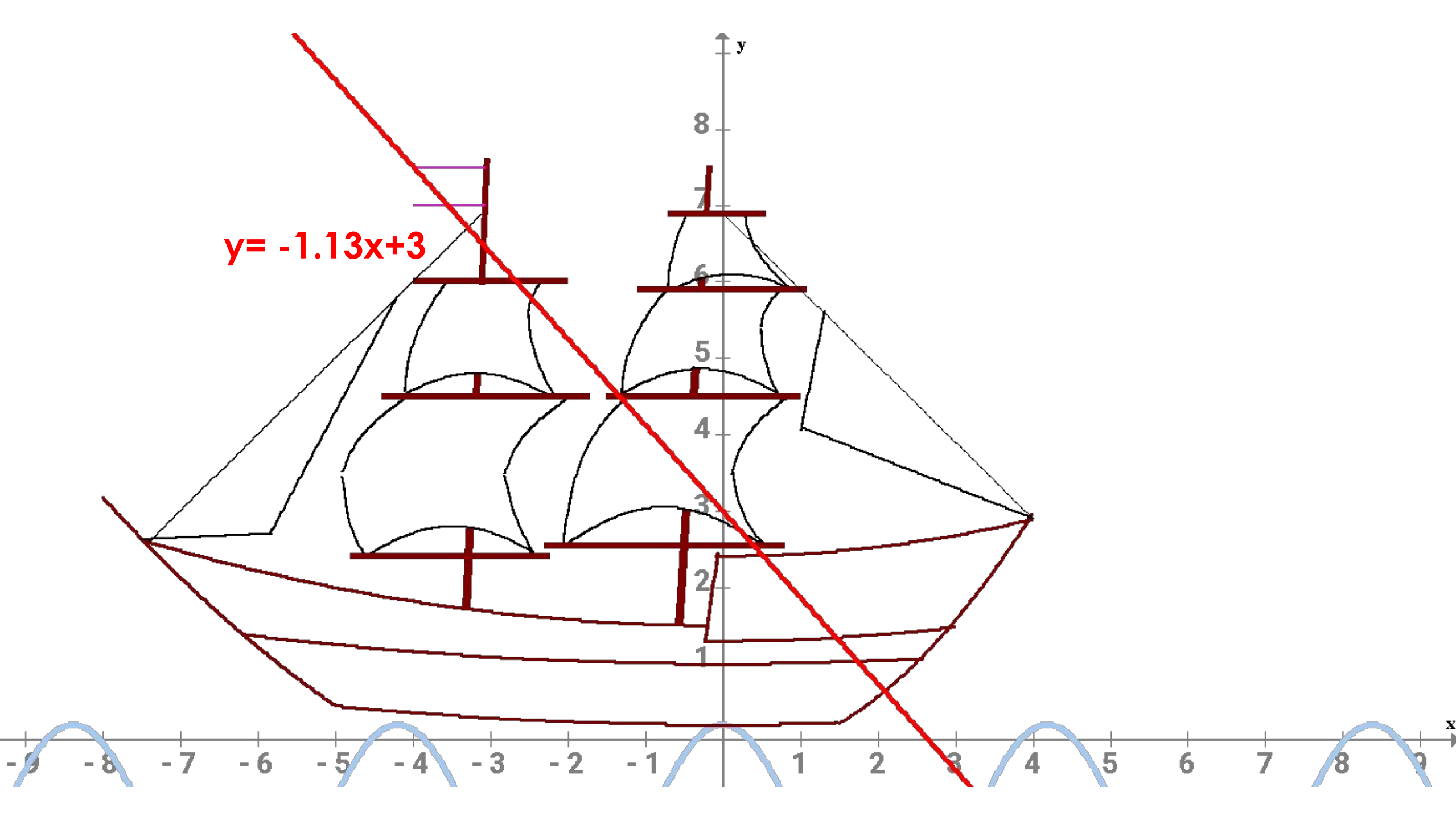

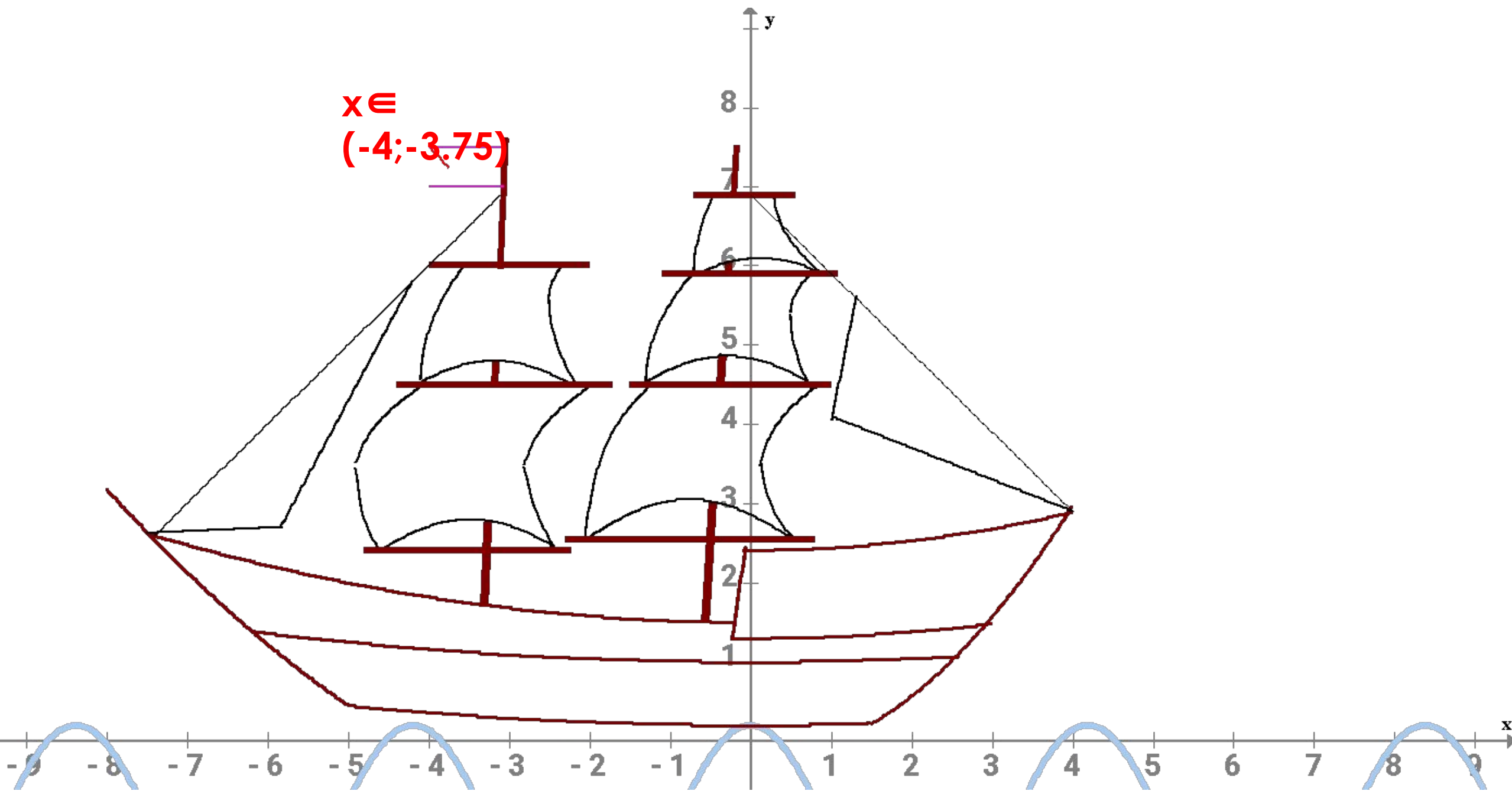

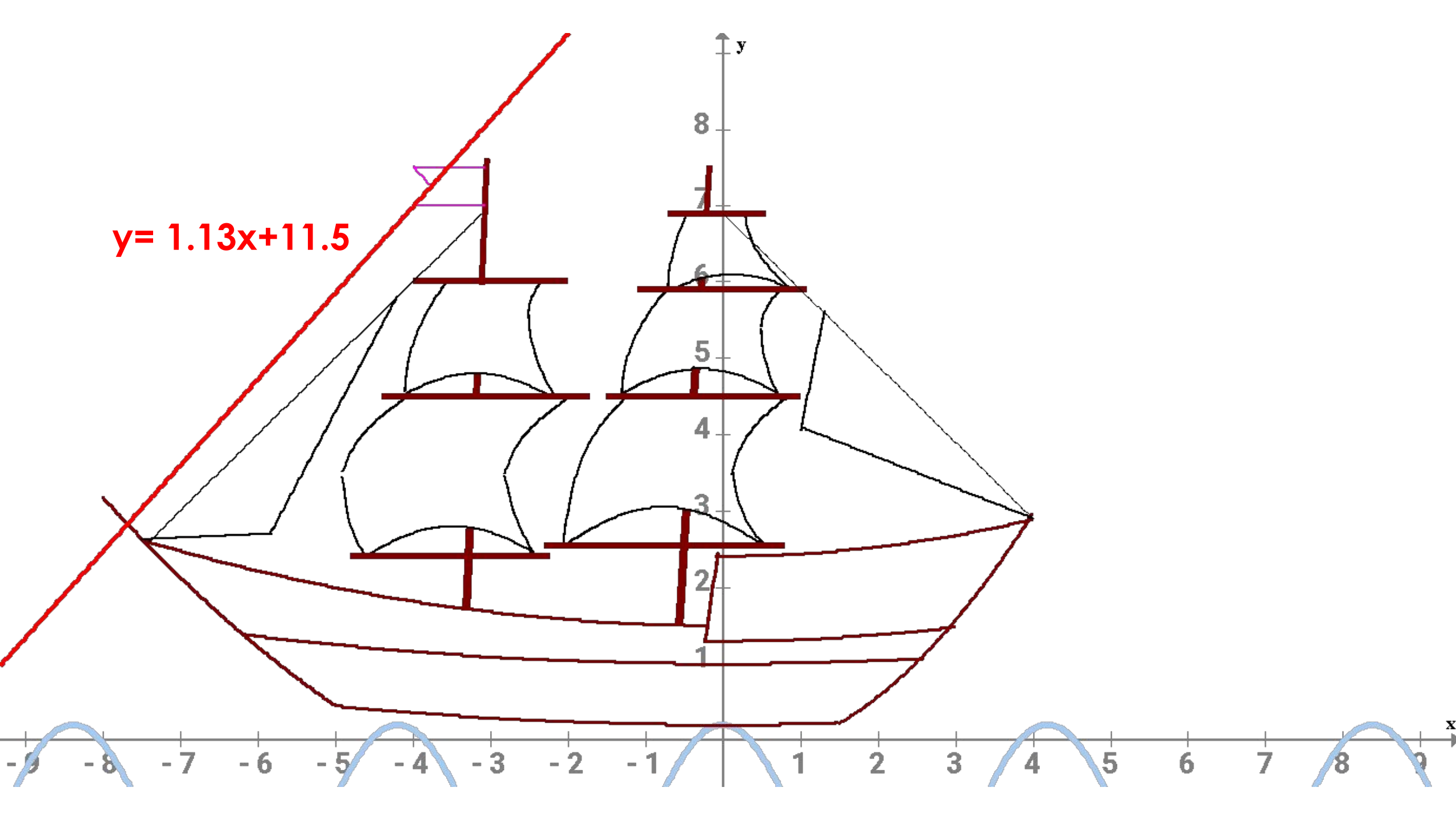

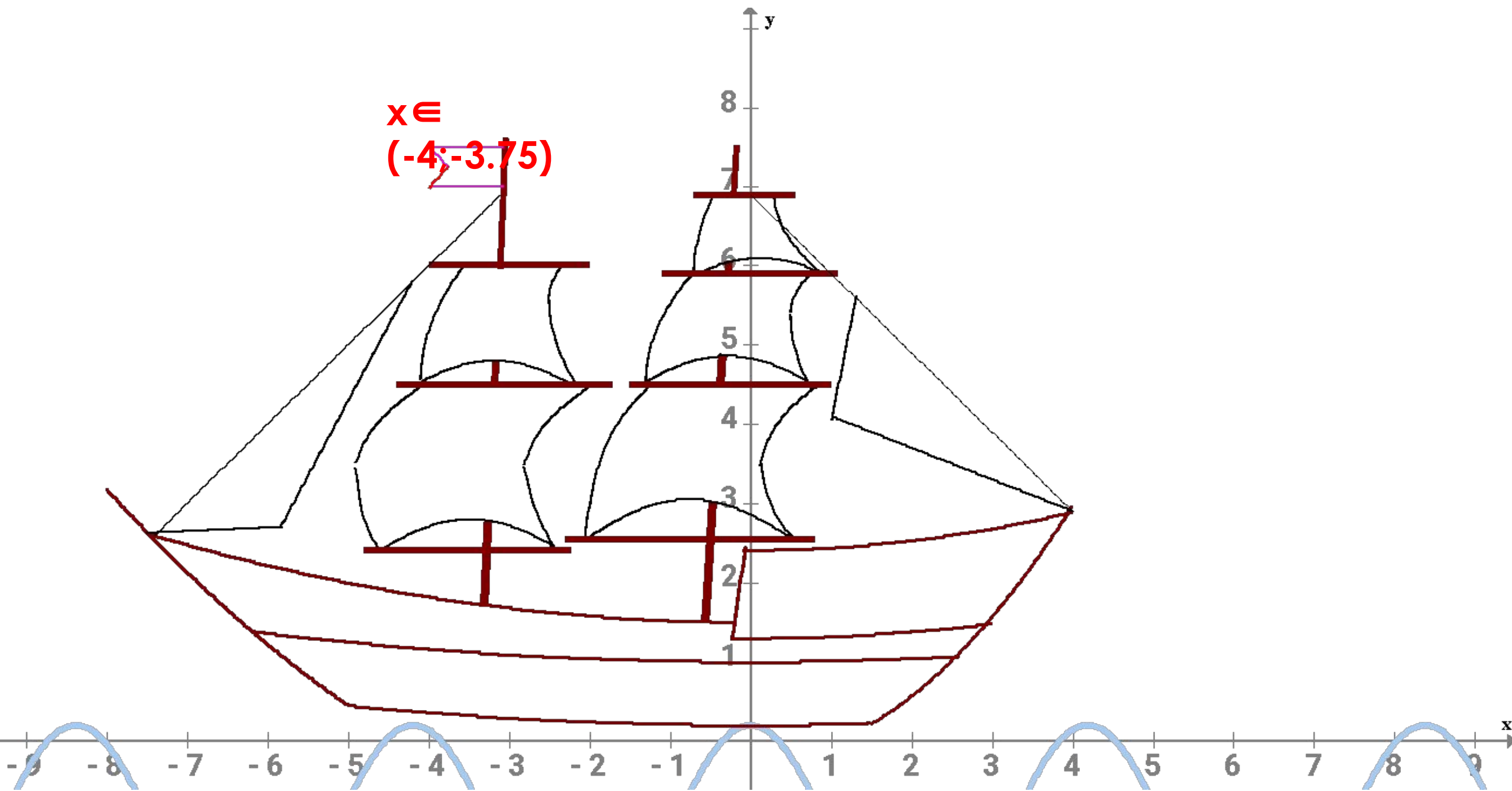

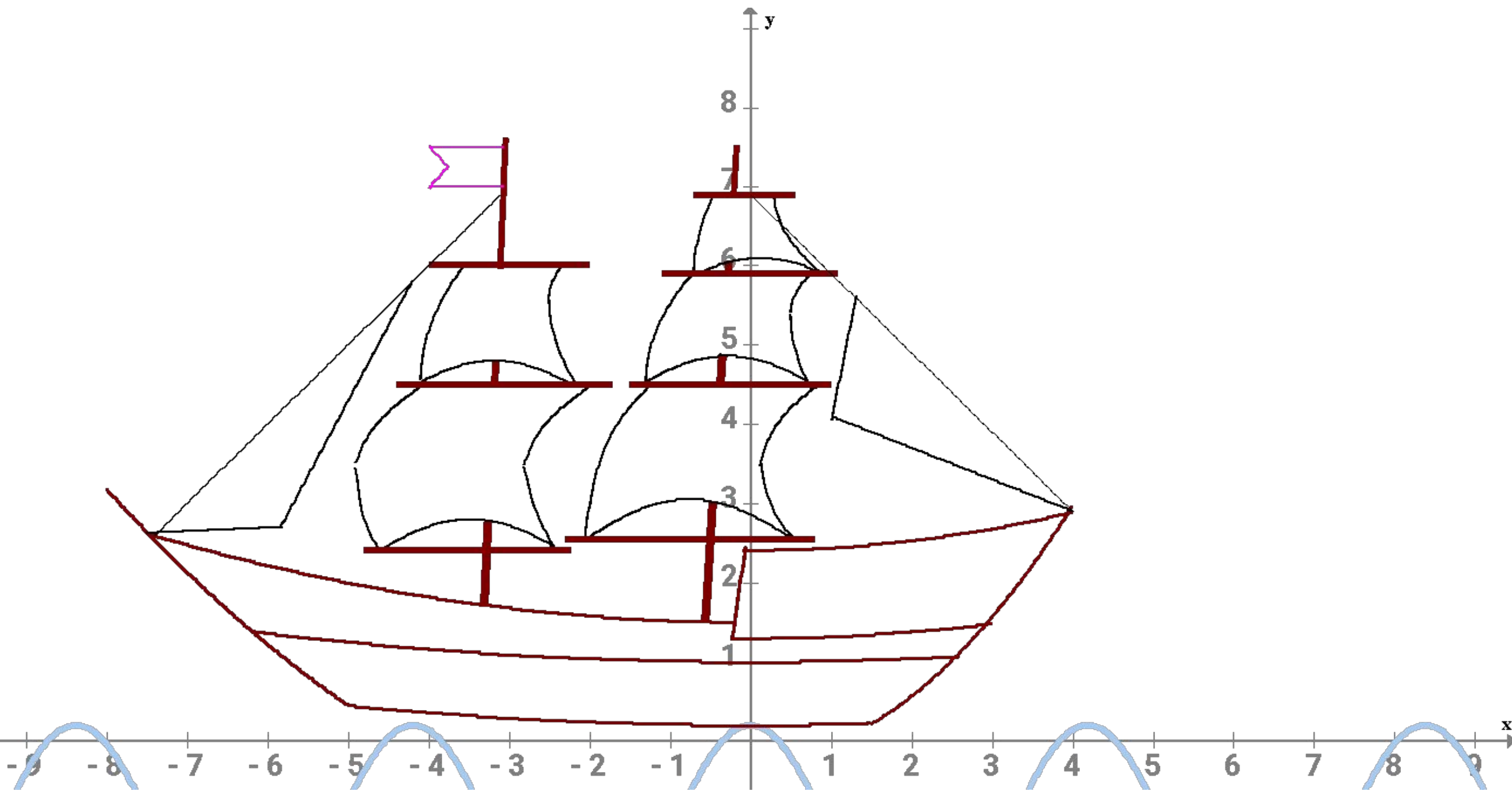

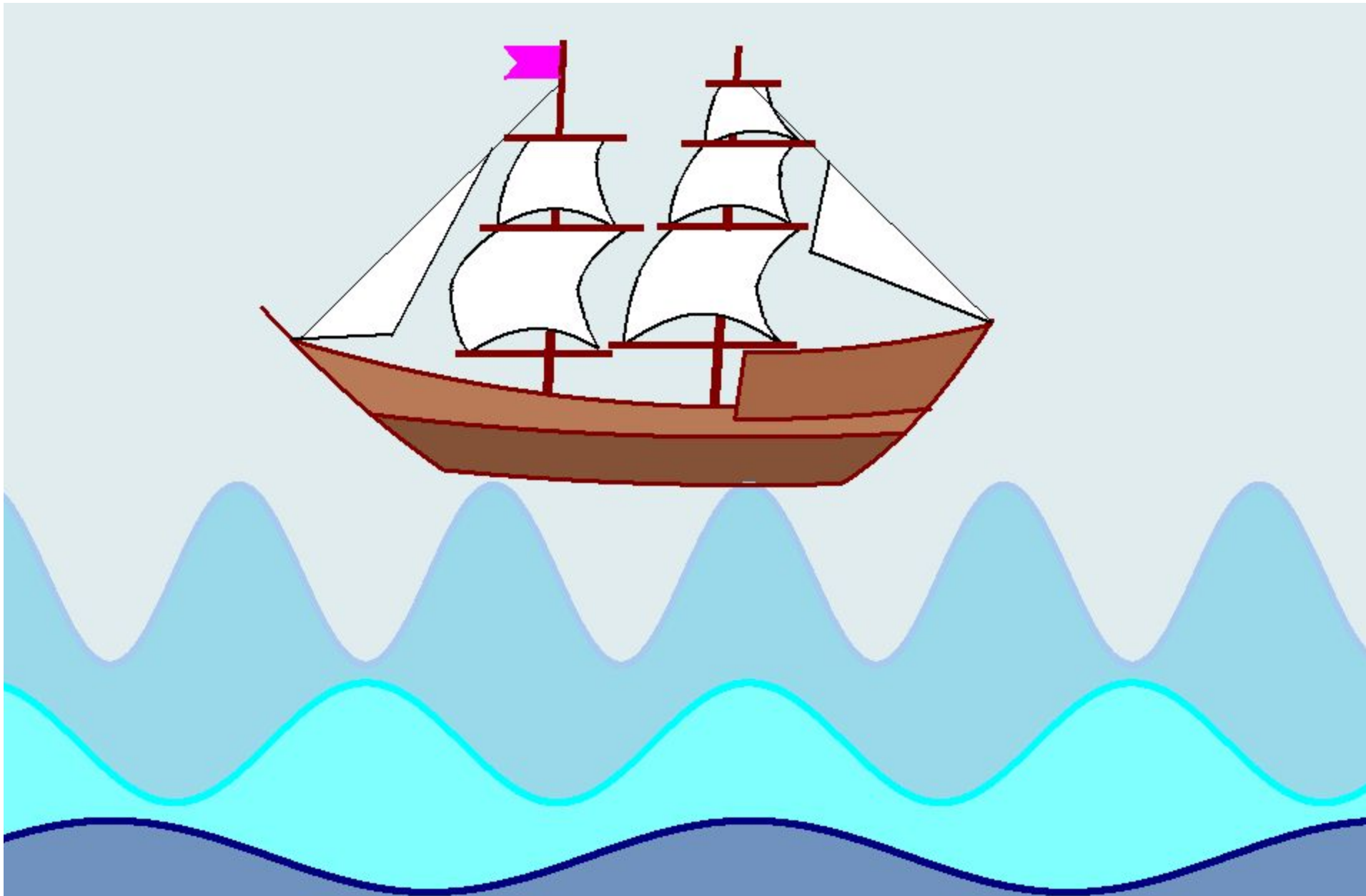

Вывод: повторила и закрепила знания, полученные в ходе изучения графиков функций и их преобразований.