

INTERNAL COMBUSTION ENGINE

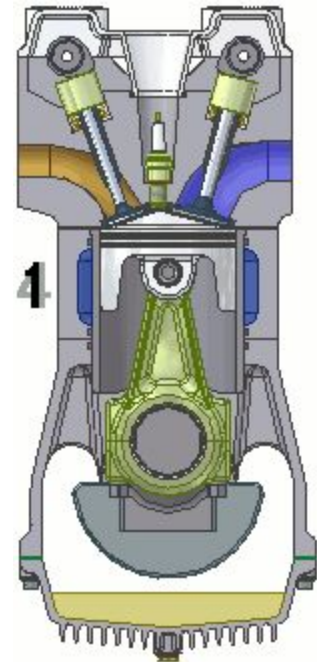

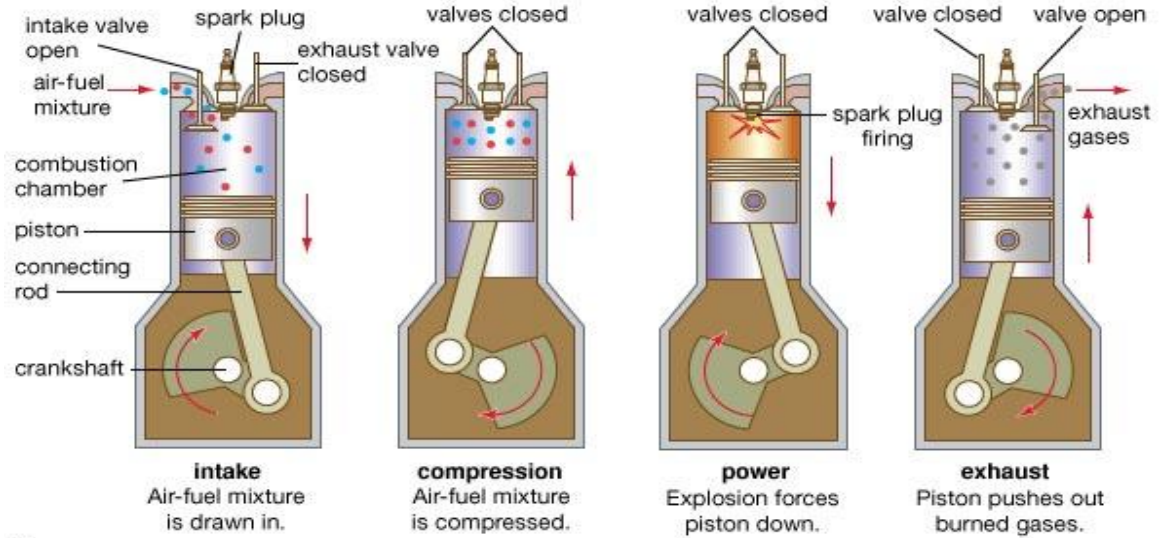

Four-stroke cycle



© 2007 Encyclopædia Britannica, Inc.



4-stroke engine model

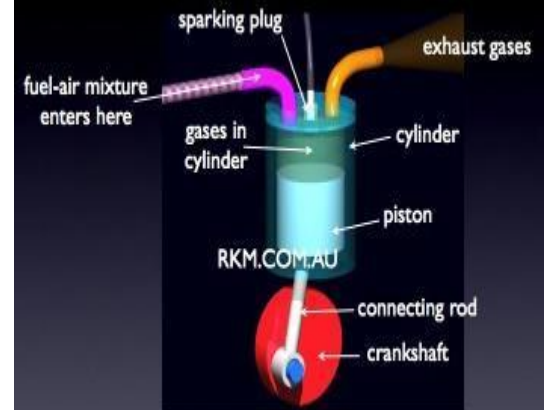

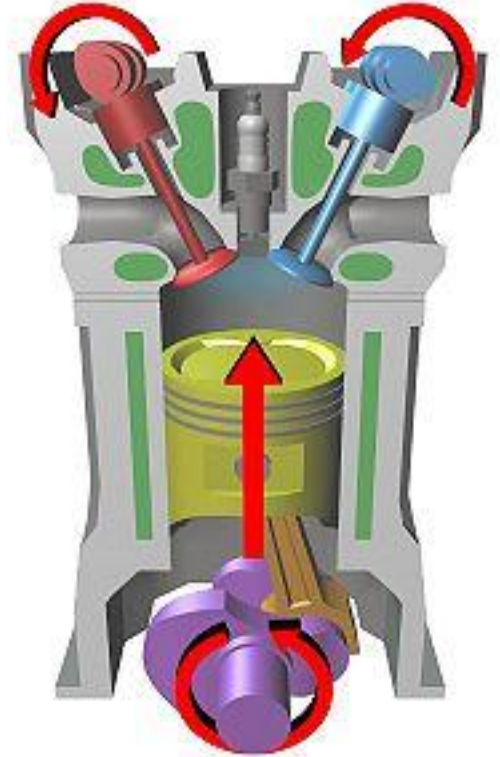

Typical Pushrod V6

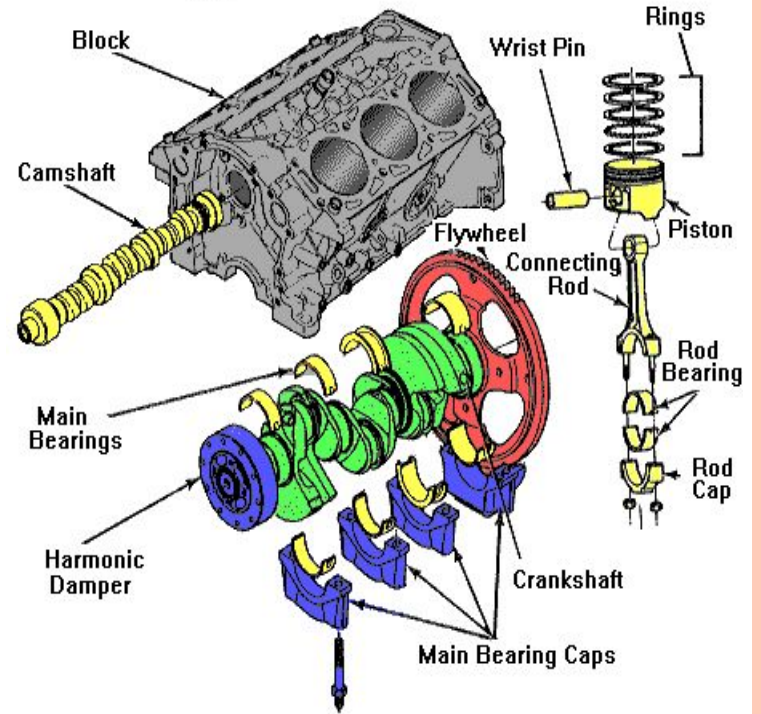

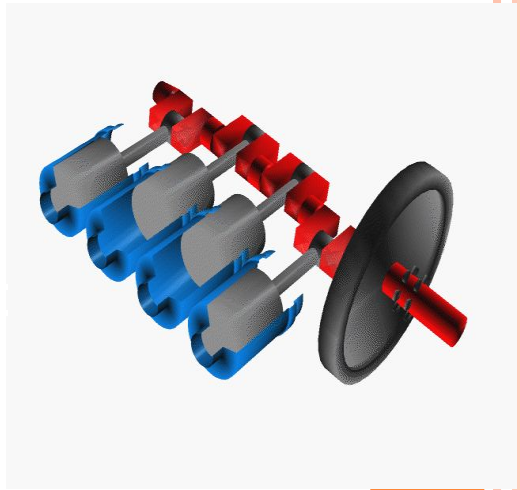

1

1



