

LRO Mission Overview

Craig Tooley - GSFC/431

September 7, 2005





2008 Lunar Reconnaissance Orbiter (LRO) First Step in the Robotic Lunar Exploration Program

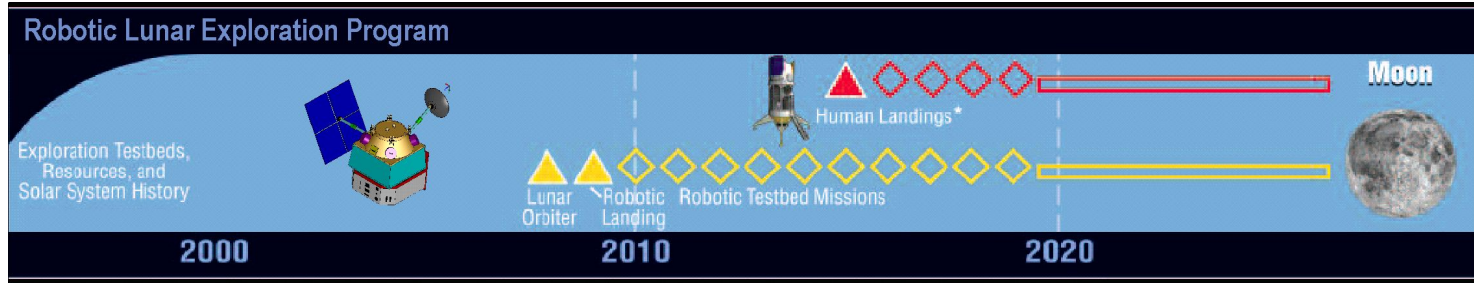
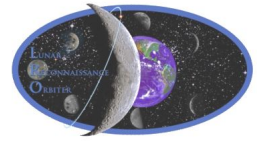

LRO Objectives

- **Characterization of the lunar radiation environment, biological impacts, and potential mitigation. Key aspects of this objective include determining the global radiation environment, investigating the capabilities of potential shielding materials, and validating deep space radiation prototype hardware and software.**
- **Develop a high resolution global, three dimensional geodetic grid of the Moon and provide the topography necessary for selecting future landing sites.**
- **Assess in detail the resources and environments of the Moon's polar regions.**
- **High spatial resolution assessment of the Moon's surface addressing elemental composition, mineralogy, and Regolith characteristics**

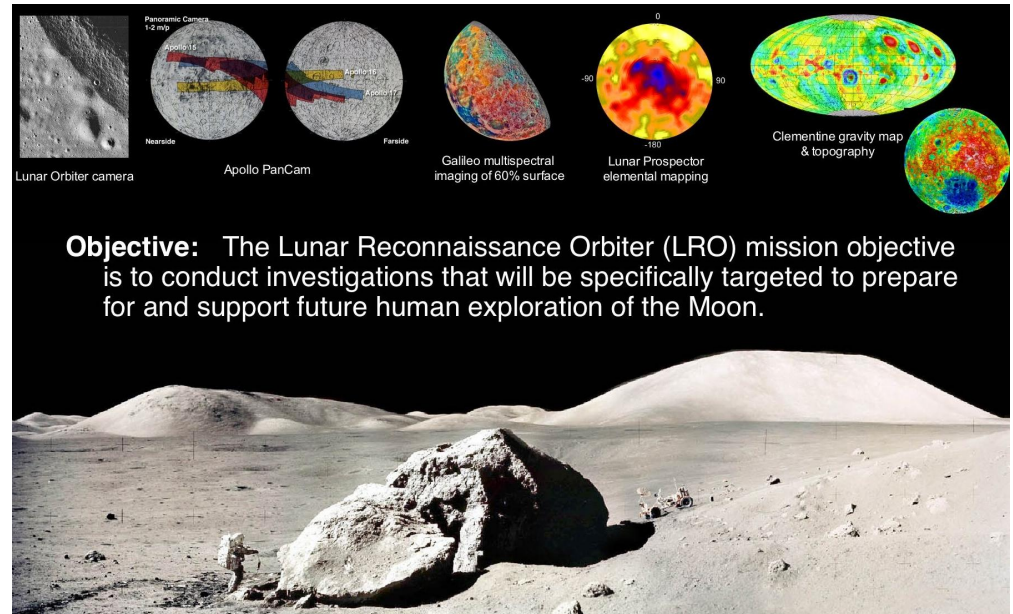



Investigation Background

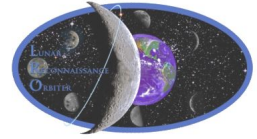

- **LRO provides major scientific and exploration benefit by 2009**
 - Apollo provided only a small glimpse of Moon; much to be explored
 - LRO address *both* science and exploration objectives
 - LRO brings many benefits (e.g., future landing sites, polar resources, safety, science)
- **LRO selected instruments complement other foreign efforts**
 - Six instruments competitively selected (“next-generation payload”)
 - Comparison to foreign systems demonstrate uniqueness and value
 - LRO will also accommodate a HQ directed Technology Demonstration payload, the Mini-RF (SAR) instrument.
- **LRO will enhance our knowledge of the Moon and increase the safety of future human missions.**
 - 3D maps of terrain and hazards, as well as of localized resources (ice) will tell us where to land (and at what precision).
 - Exploration of new sites where resources may be available requires new and timely knowledge of those sites at scales never before possible.
- **Current state of knowledge does not allow us to reduce the risk and cost of humans landing and working on the Moon.**
 - Equatorial environment (terrain, thermal, lighting) is different from polar region.
 - Apollo Program flight system capability limited to equatorial region (capability)



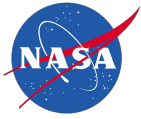

Benefit Example: Identifying Landing Sites & Resources

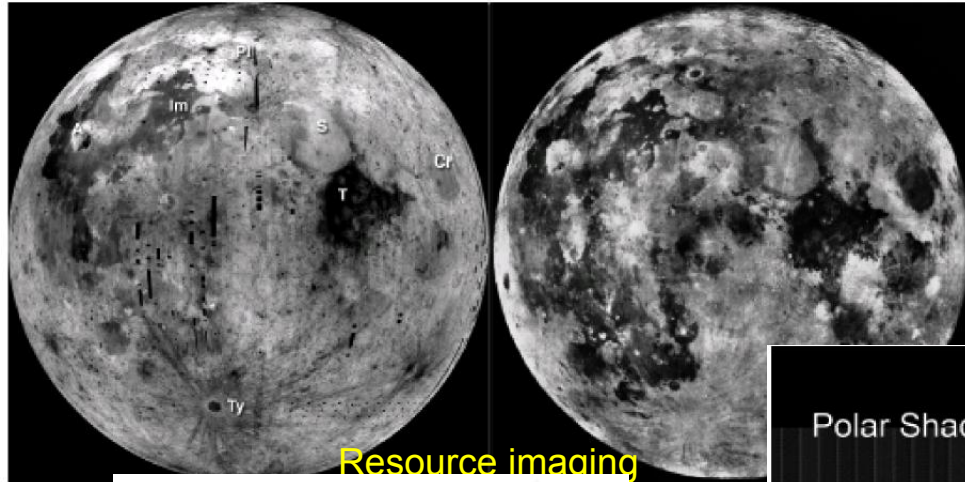

Resource imaging



Temperature mapping (find cold traps)

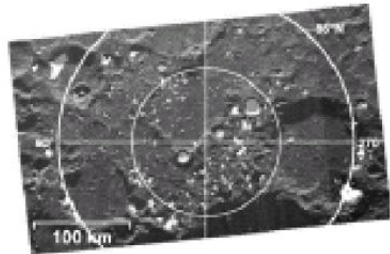

Polar Topography/shadow mapping

<p>Polar Shadows</p>	<p>Landing Sites</p>	<p>Current Impact Rate</p>
<p>Resources</p>	<p>Regolith Properties</p>	<p>High-Resolution Topography</p>



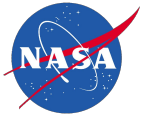

LRO Mission Overview

Flight Plan – Direct using 3-Stage ELV

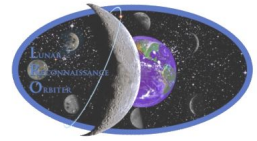

- Launch in late 2008 on a Delta II rocket into a direct insertion trajectory to the moon.
- On-board propulsion system used to capture at the moon, insert into and maintain 50 km altitude circular polar reconnaissance orbit.
- 1 year mission
- Orbiter is a 3-axis stabilized, nadir pointed spacecraft designed to operate continuously during the primary mission.

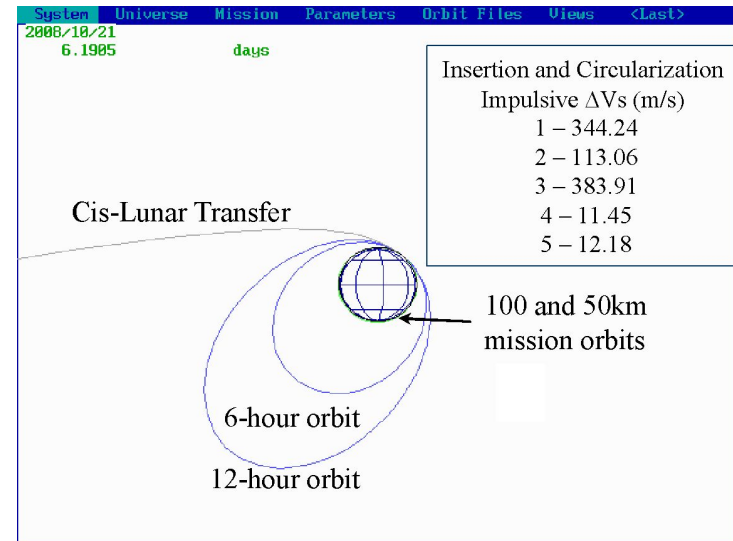
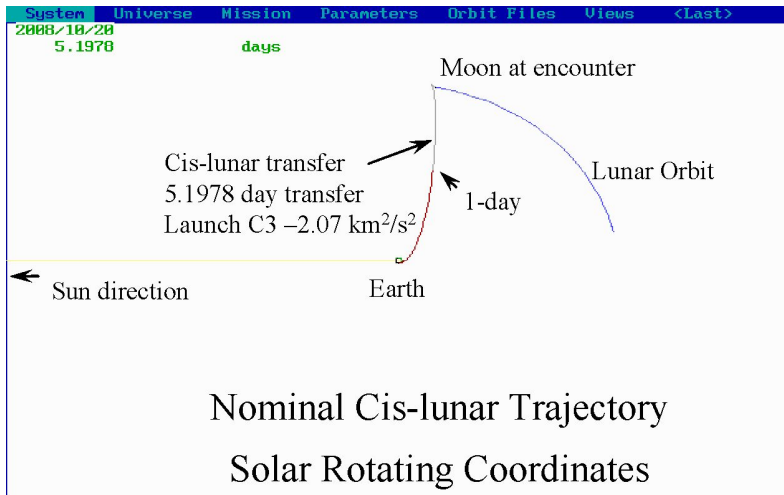

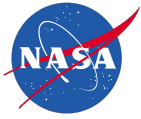

LRO Mission Overview

Orbiter

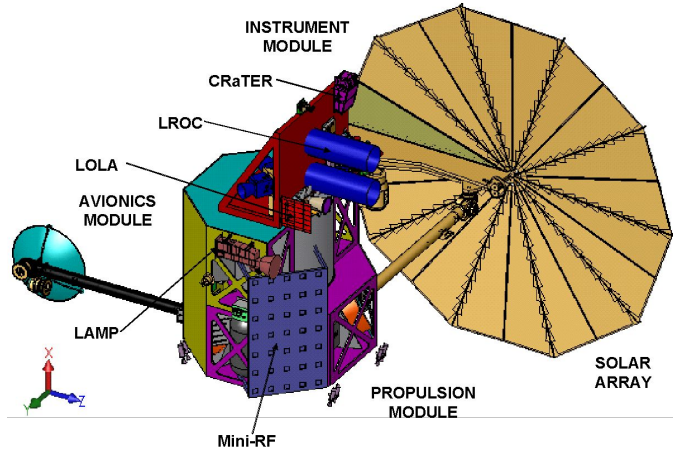
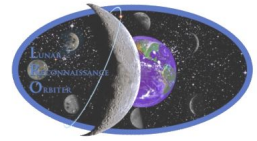

LRO Preliminary Design

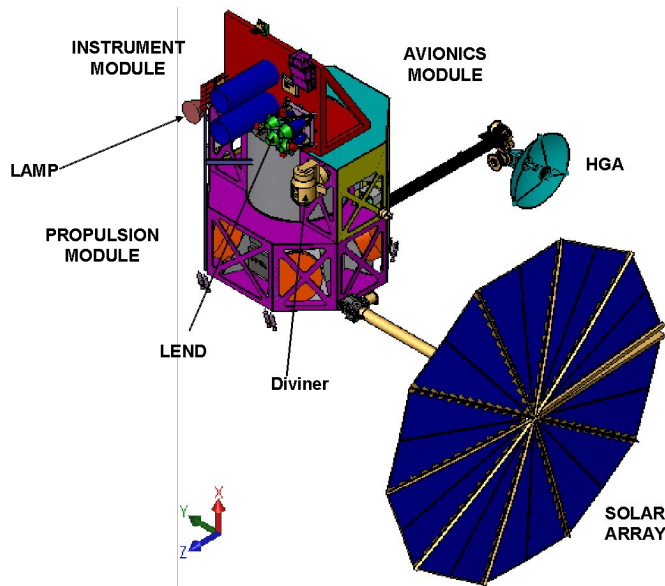

LRO Instruments

- **Lunar Orbiter Laser Altimeter (LOLA) Measurement Investigation** – LOLA will determine the global topography of the lunar surface at high resolution, measure landing site slopes and search for polar ices in shadowed regions.
- **Lunar Reconnaissance Orbiter Camera (LROC)** – LROC will acquire targeted images of the lunar surface capable of resolving small-scale features that could be landing site hazards, as well as wide-angle images at multiple wavelengths of the lunar poles to document changing illumination conditions and potential resources.
- **Lunar Exploration Neutron Detector (LEND)** – LEND will map the flux of neutrons from the lunar surface to search for evidence of water ice and provide measurements of the space radiation environment which can be useful for future human exploration.
- **Diviner Lunar Radiometer Experiment** – Diviner will map the temperature of the entire lunar surface at 300 meter horizontal scales to identify cold-traps and potential ice deposits.
- **Lyman-Alpha Mapping Project (LAMP)** – LAMP will observe the entire lunar surface in the far ultraviolet. LAMP will search for surface ices and frosts in the polar regions and provide images of permanently shadowed regions illuminated only by starlight.
- **Cosmic Ray Telescope for the Effects of Radiation (CRaTER)** – CRaTER will investigate the effect of galactic cosmic rays on tissue-equivalent plastics as a constraint on models of biological response to background space radiation.

Preliminary LRO Characteristics



Mass	1317 kg	Dry: 603 kg
		Fuel: 714 kg
Power	745 W	
Measurement Data Volume	575 Gb/day	

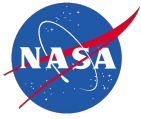

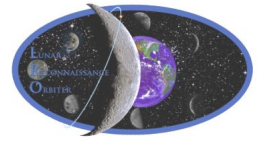

Competitively Selected LRO Instruments Provide Broad Benefits

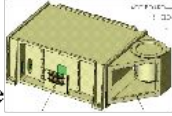

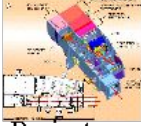
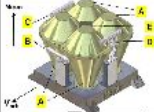
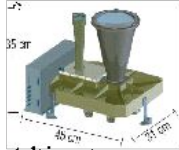
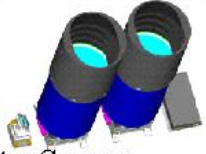
INSTRUMENT	Measurement	Exploration Benefit	Science Benefit
CRaTER (BU+MIT) Cosmic Ray Telescope for the Effects of Radiation 	<i>Tissue equivalent response to radiation</i>	<i>Safe, lighter weight space vehicles that protect humans</i>	<i>Radiation conditions that influence life beyond Earth</i>
Diviner (UCLA) 	<i>300m scale maps of Temperature, surface ice, rocks</i>	<i>Determines conditions for systems operability and water-ice location</i>	<i>Improved understanding of volatiles in the solar system - source, history, migration and deposition</i>
LAMP (SWRI) Lyman-Alpha Mapping Project 	<i>Maps of frosts in permanently shadowed areas, etc.</i>	<i>Locate potential water-ice (as frosts) on the surface</i>	
LEND (Russia) Lunar Exploration Neutron Detector 	<i>Hydrogen content in and neutron radiation maps from upper 1m of Moon at 5km scales, Rad > 10 MeV</i>	<i>Locate potential water-ice in lunar soil and enhanced crew safety</i>	
LOLA (GSFC) Lunar Orbiter Laser Altimeter 	<i>~50m scale polar topography at < 1m vertical, roughness</i>	<i>Safe landing site selection, and enhanced surface navigation (3D)</i>	<i>Geological evolution of the solar system by geodetic topography</i>
LROC (NWU+MSSS) Lunar Recon Orbiter Camera 	<i>1000's of 50cm/pixel images (125km²), and entire Moon at 100m in UV, Visible</i>	<i>Safe landing sites through hazard identification; some resource identification</i>	<i>Resource evaluation, impact flux and crustal evolution</i>





LRO Spacecraft Systems Block Diagram

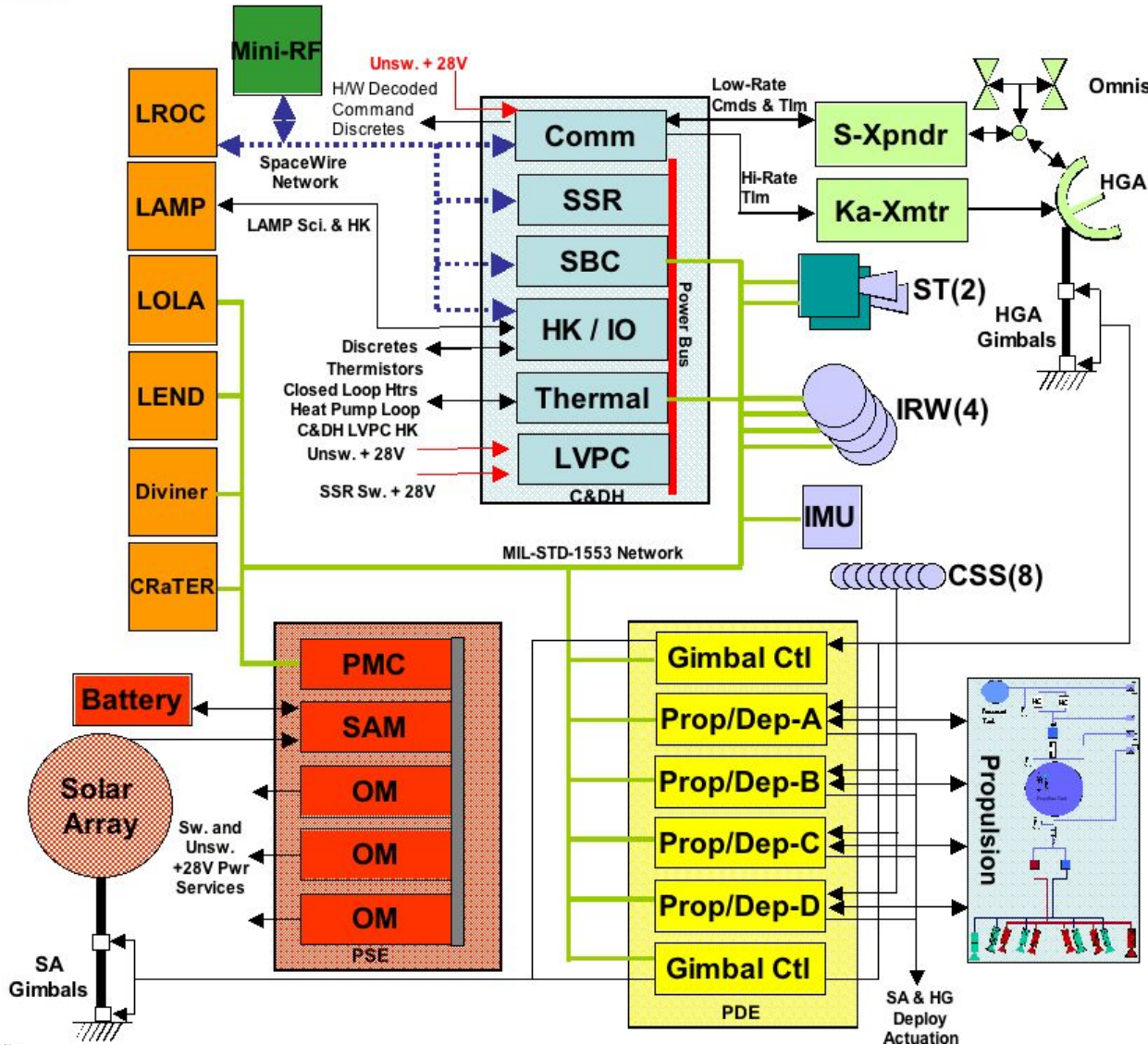

C&DH	Command & Data Handling
Comm	Communications
CRaTER	Cosmic Ray Telescope for the Effects of Radiation
CSS	Coarse Sun Sensor
EVD	Engine Valve Driver
HGA	High-Gain Antenna
H/W	Hardware
HK	Housekeeping
IO	Input/Output
IMU	Integrated Momentum Unit
IRW	Integrated Reaction Wheel
LAMP	Lyman-Alpha Mapping Project
LEND	Lunar Exploration Neutron Detector
LOLA	Lunar Orbiter Laser Altimeter
LROC	Lunar Reconnaissance Orbiter Camera
LVPC	Low Voltage Power Converter
OM	Output Module
PDE	Propulsion Deployable Electronics
PMC	Power Management Controller
PSE	Power System Electronics
SA	Solar Array
SAM	Solar Array Module
ST	Star Tracker
SBC	Single Board Computer
SSR	Solid State Recorder
Xmtr	Transmitter
Xpndr	Transponder
Mini-RF	





LRO C&DH Architecture Block Diagram (New-8/29/05)

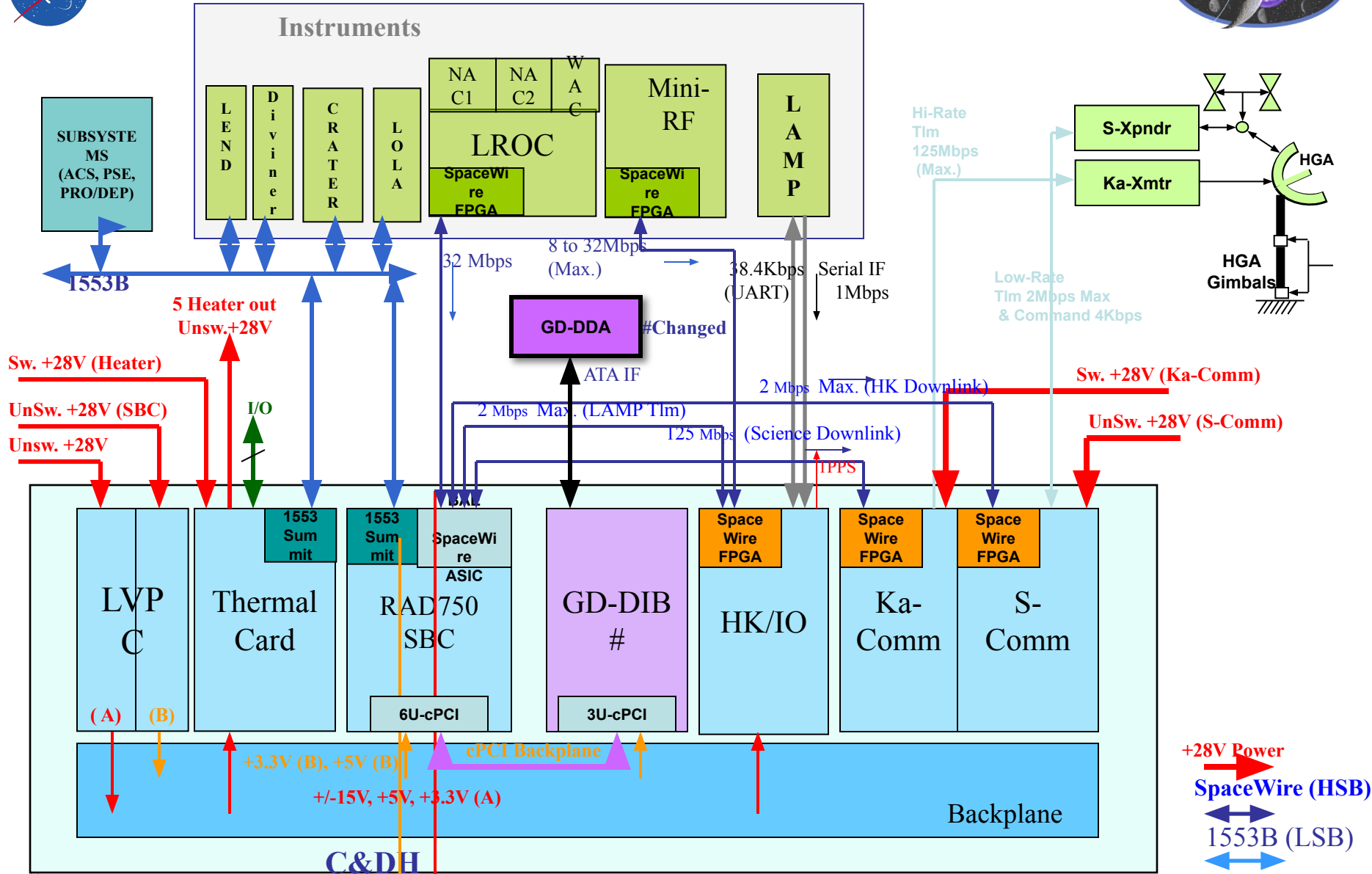
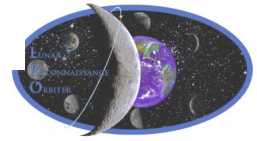



LRO Spacecraft Systems Capabilities

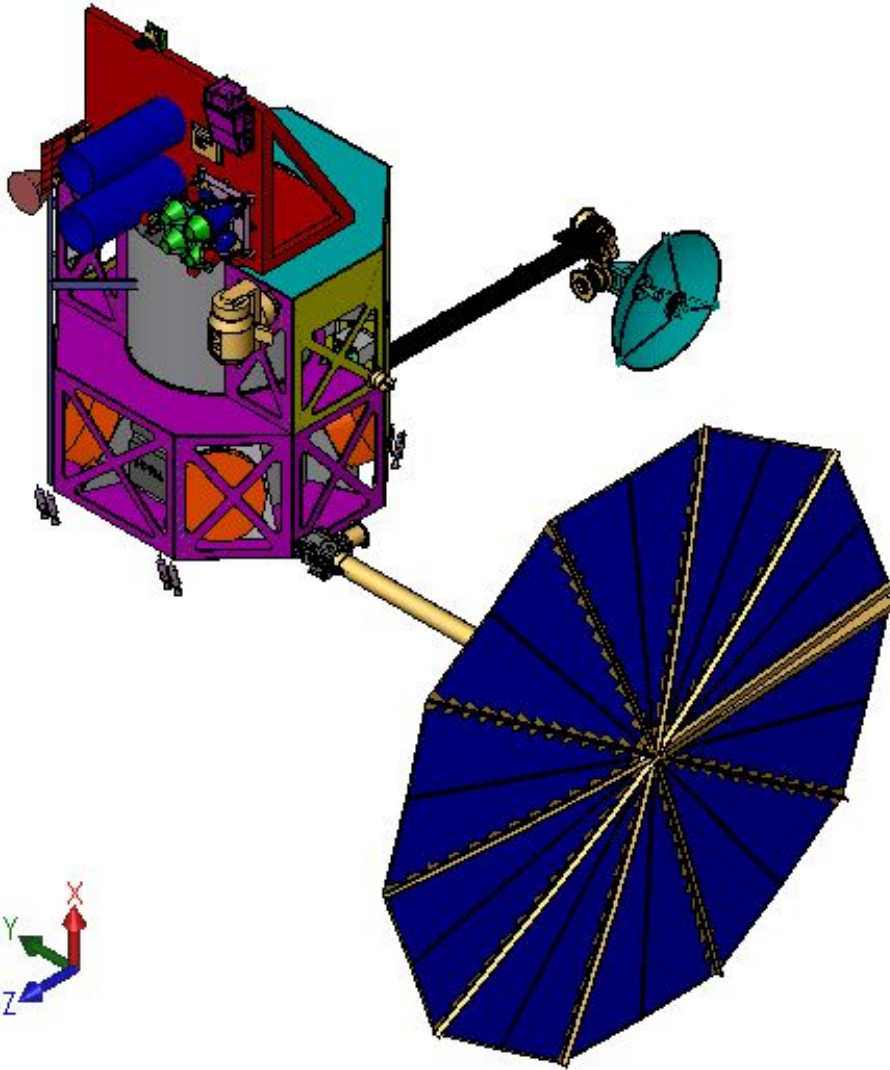
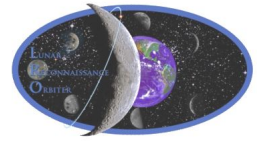

LRO Overview

- 6 Instruments and 1 Technical Demonstration**
- 3 Spacecraft Modules – Instrument, Propulsion, Avionics**
- 2 Deployable Systems – High Gain Antenna, Solar Array**
- 2 Data Buses – Low Rate 1553, High Rate Spacewire**
- 2 Comm Links – S Band, Ka Band**
- Monopropellant System – Hydrazine, Single Tank design**

LRO Capability Highlights

- Mass: 1480 kg**
- Power: 823 W orbit average @ 35V**
- Battery: Lithium Ion Chemistry**
80 Amp-Hour Capacity
- Data Storage Capacity: 400 Gb**
- Data Rate: 100 Mbps Down – Ka Band**
2.186 Mbps Up/Down – S Band
- Timing relative to UTC: 3ms**
- Delta V Capability: 1326 m/sec**
- Pointing Accuracy: 60 Asec relative to GCI**
- Pointing Knowledge: 30 Asec relative to GCI**



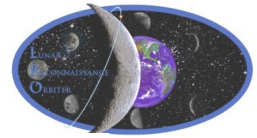
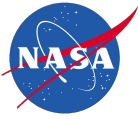

Ground System Architecture Overview

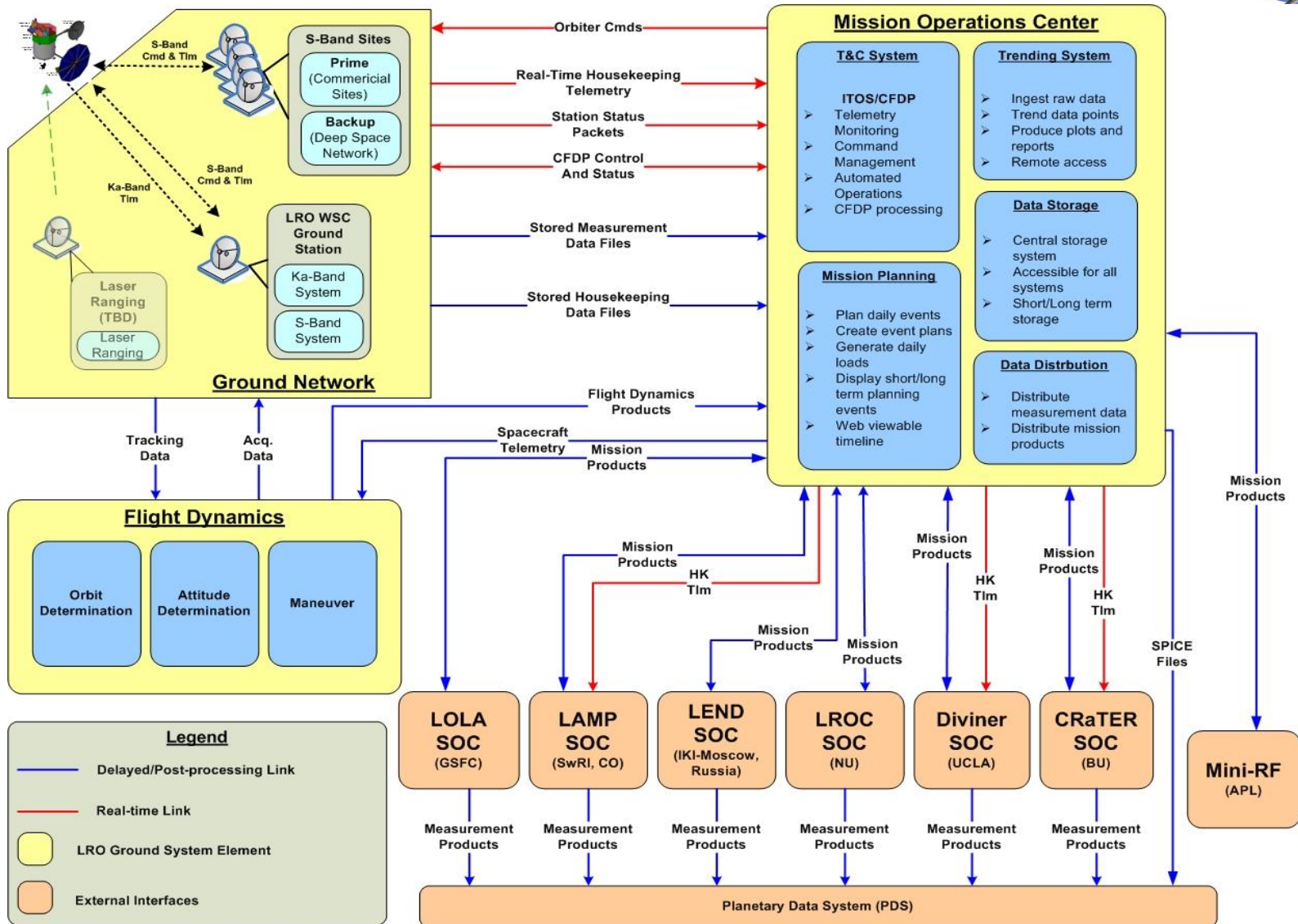

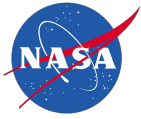

LRO Mission Phases Overview



No	Phase	Sub-Phases	Description
1	Pre-Launch/ Launch Readiness	<ul style="list-style-type: none"> <input type="checkbox"/> Space Segment Readiness <input type="checkbox"/> Ground Segment Readiness 	Includes instrument I&T, spacecraft/orbiter I&T, space/ground segment testing as well as operations preparation and ground readiness testing leading up to launch.
2	Launch & Lunar Transfer	<ul style="list-style-type: none"> <input type="checkbox"/> Launch and Ascent <input type="checkbox"/> Separation and De-spin <input type="checkbox"/> Deployment and Sun Acq. <input type="checkbox"/> Lunar Cruise <input type="checkbox"/> Lunar Orbit Insertion 	Includes all activities & operations from launch countdown sequence to Lunar Orbit Insertion (LOI). LOI includes all maneuvers necessary to obtain the temporary parking orbit for Orbiter activation and commissioning. During the cruise phase, initial spacecraft checkout will be performed to support activities for mid course correction (MCC) and LOI.
3	Orbiter Commissioning	<ul style="list-style-type: none"> <input type="checkbox"/> Spacecraft Commissioning <input type="checkbox"/> Integrated Instrument Commissioning 	Configure and checkout the spacecraft subsystems and ground systems prior to instrument turn-on. Instrument integrated activation will be developed to complete instruments turn-on and commissioning. Instrument commissioning includes any calibration activities needed in the temporary orbit.
4	Routine Operations	<ul style="list-style-type: none"> <input type="checkbox"/> Measurements (Routine Ops) <input type="checkbox"/> Station-keeping <input type="checkbox"/> Momentum Management <input type="checkbox"/> Instrument Calibrations <input type="checkbox"/> Lunar Eclipse <input type="checkbox"/> Yaw Maneuver <input type="checkbox"/> Safe Mode 	One year of nominal science collection in the 50 (+/- 20) km orbit.
5	Extended Mission Operations		After 1-year of science observations, orbiter will be boosted into a higher orbit to reduce maintenance requirements. Potential purpose for extended mission operations may be to perform relay comm. operations. Alternatively additional measurement operations may be performed for a shorter period in a continued low orbit.
6	End-of-Mission Disposal		Includes planning and execution of end-of-life operations. LRO will impact lunar surface.



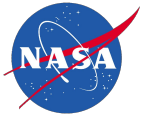

LRO Project Organization

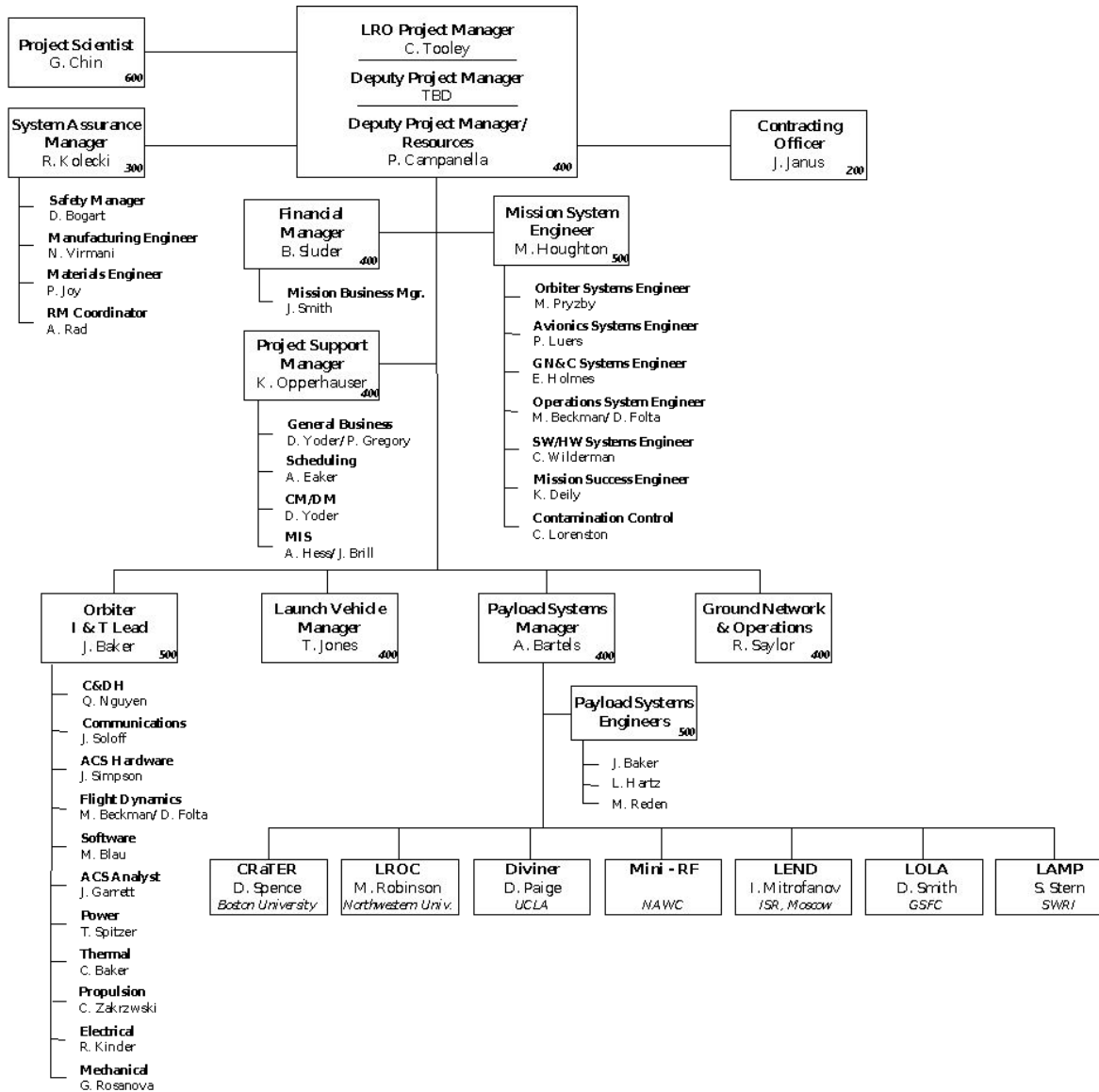
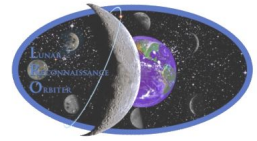

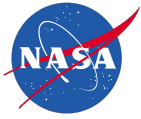

LRO Mission Schedule

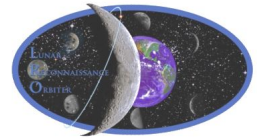

Ver. 0.9

Mission PDR target: November 14

7/31/05

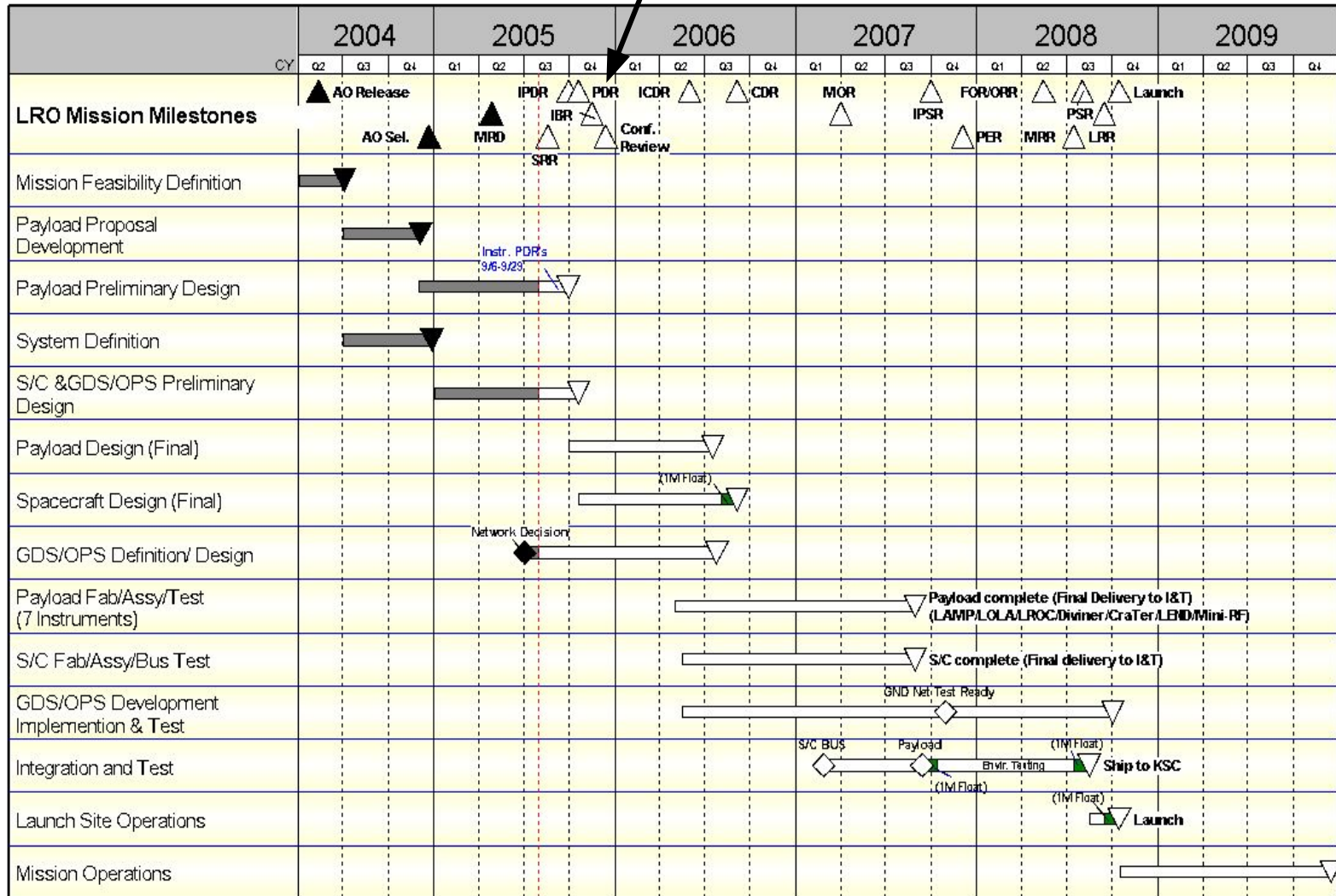

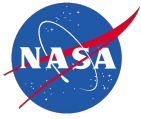

LRO Project Overall Status

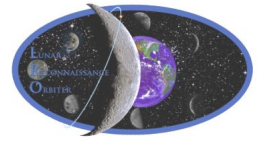

- **Project almost fully staffed**
 - 45 civil servants & 23 support contractor at present (FTEs & WYEs)
 - Project level augmentations in-work as Program/Project resources are phased out.
- **Project infrastructure in-place**
 - Project organization and staffing being adjusted in reaction to RLEP transfer to ARC
- **Project Plan drafted for November 2004 Program review**
 - Currently being revised to reflect RLEP move to ARC & to comply with NPR 7120.5 rev. C
- **Mission SRR successfully conducted August 16-17**
- **Major system trades nearly complete**
 - C&DH Architecture ✓
 - Propulsion System ✓
 - Ground Network ✓
 - Data Recorder Technology ✓
 - High Accuracy Tracking Methodology ✓
- **Level 2 & Level 3 Requirements established and moving thru review/approval cycles – SRR successfully completed**
- **Overall integrated mission development schedule developed and in review**
 - Baselined after PDR in preparation for Confirmation





LRO Element Development Status



- **Instruments – high heritage proposed designs converging to preliminary designs**
 - Design efforts primarily focused in two areas
 - Design modifications to adapt to LRO command/data interfaces
 - Design modifications driven by lunar thermal environment
 - Low lunar polar orbit is significantly different than Mars missions where most instrument heritage is from.
 - Interfaces with spacecraft well defined – ICDs in review/release cycle
 - Allocations released and agreed upon
 - LRO Payload Science Working Group formed and functioning
 - Consists of PI's lead by LRO Project Scientist
 - Integral part of LRO mission operations planning
- **Spacecraft bus – AO design concept evolving to preliminary design**
 - All subsystems on track for mission PDR this Fall
 - Propulsion subsystem moved in-house at GSFC – leverages HST-DM surplus hardware
 - Spacecraft Computer specified and under development on ESES contract
 - SQ-RAID (hard disk) technology selected for data recorder. Acquisition now in-work.
 - Subsystem technical Peer Review being conducted Sept. - November
 - Approximately \$15M in direct procurements planned during Sept.-Dec.
- **Ground Systems – architecture and acquisition approach defined**
 - Mission Operations Center
 - Preliminary design established based on GSFC heritage systems
 - Location established, initial facility agreements in-place
 - Ground Network
 - Requirements and architecture established
 - Primary 18m antenna procurement contract in place
 - GSFC Ground Networks providing end-to-end system
 - Development tasks on NENS contract established
 - SRR Planned for November





LRO Requirements

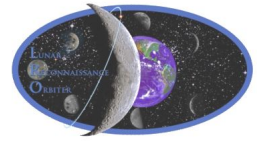

- Mission SRR held 9/16-17/2005 – judged very successful
 - Review covered development and flow down of level 2 and 3 requirements from the NASA ESMD Level 1 requirements
 - Instruments presented flow down of Level 1 measurement and data product requirements to their level 2 and 3 performance and functional requirements
 - Project presented flow down of level 2 and 3 mission, spacecraft, and ground system requirements
 - ~ 50 RFAs/Comments, none specific to instruments.
 - Level 1 requirements being refined by ESMD with Project and assistance.
 - Ongoing work includes establishment of Mission Success Criteria
 - SRR demonstrated that instrument requirements are established, understood, and realizable.





LRO Requirements Development Roadmap

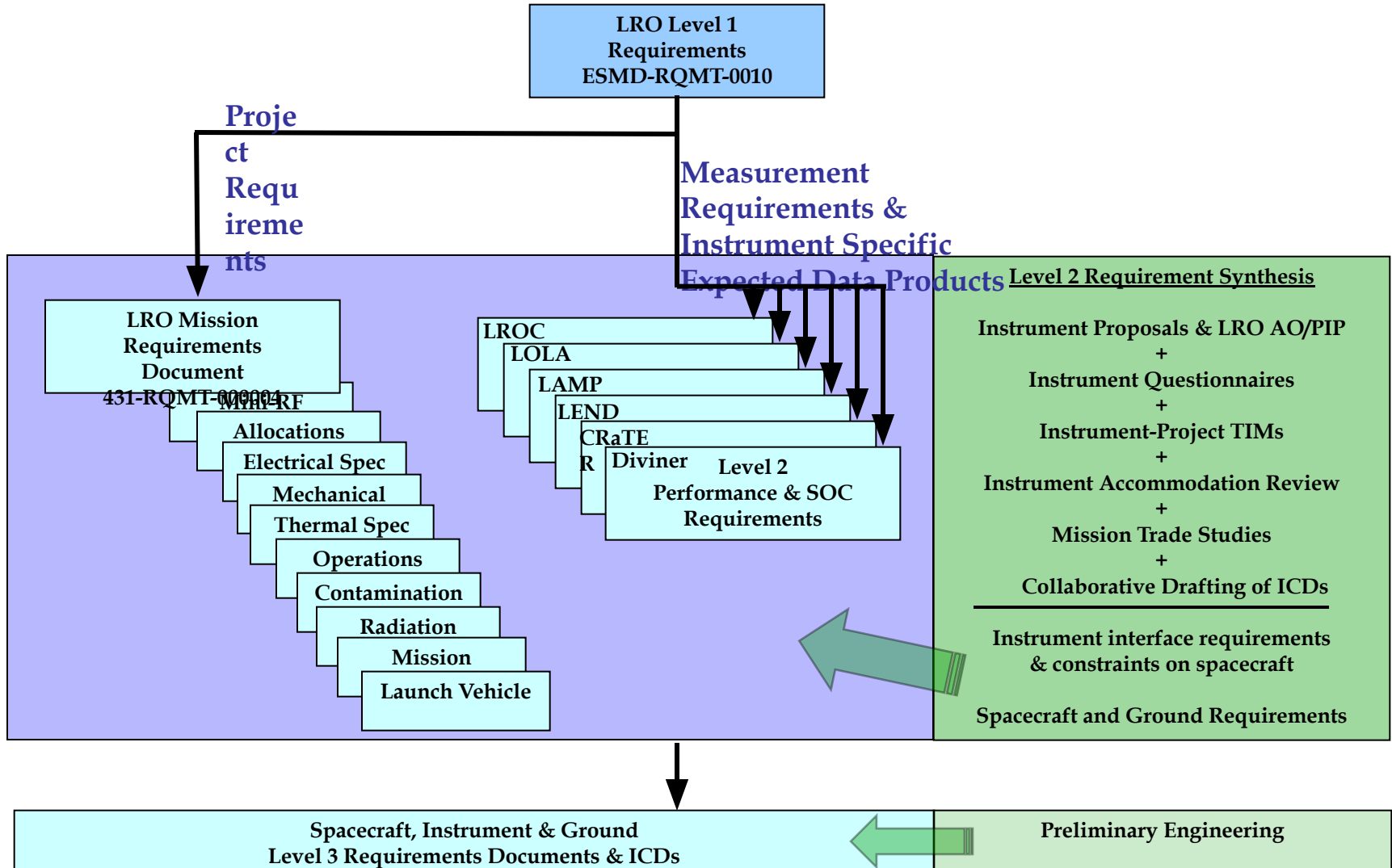
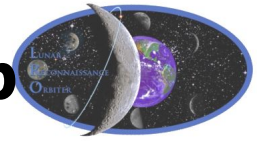



LRO Overview

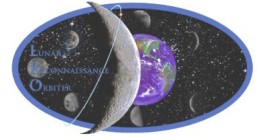

Back-Ups



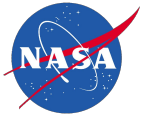

LRO Timeline to Confirmation

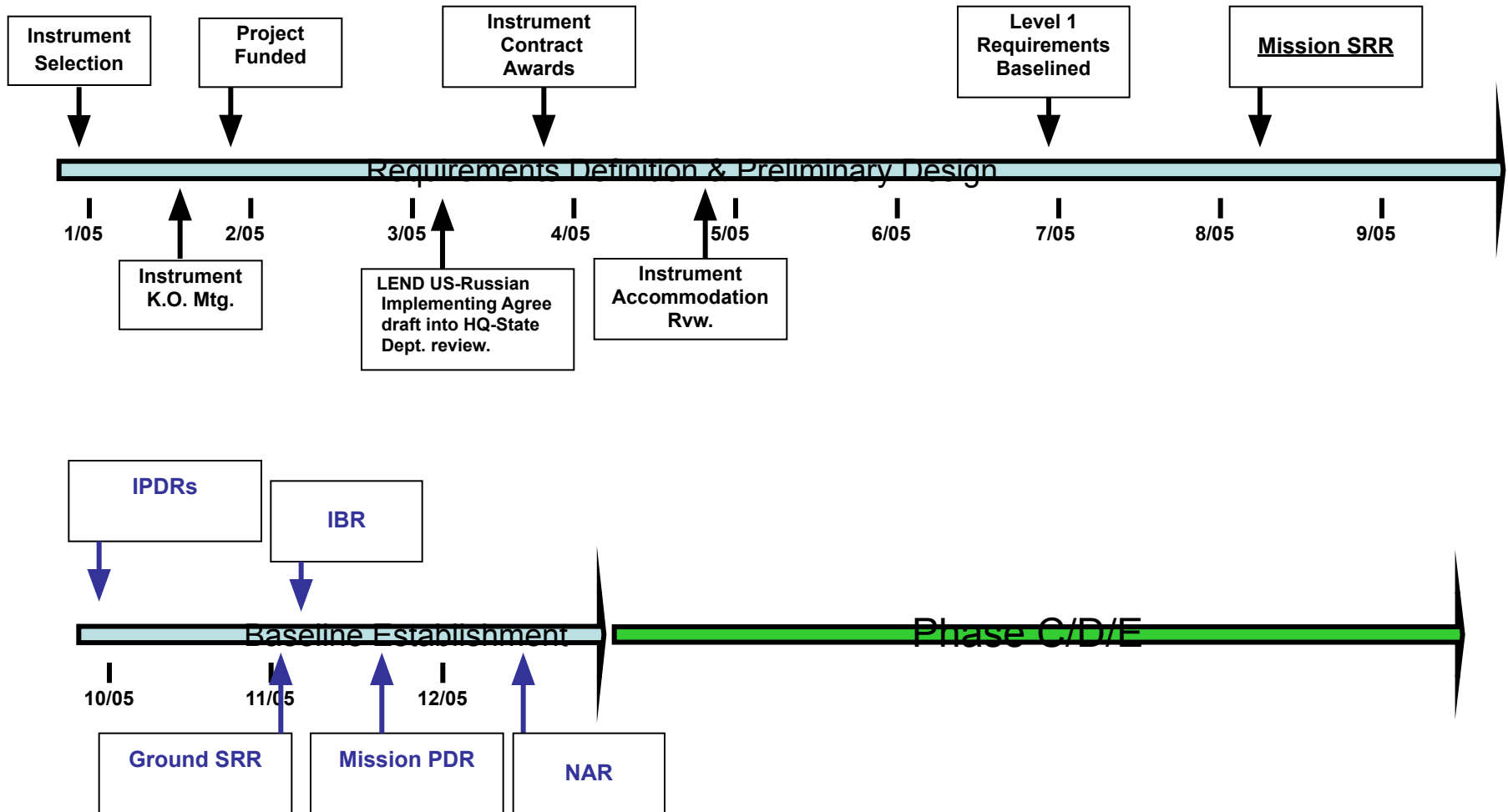
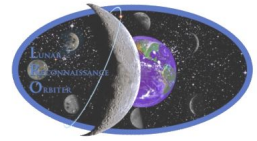

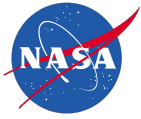

LRO Lifecycle Cost Estimate

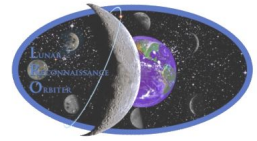

- LRO LCC estimate is in process.

Initial Cost Estimate (\$M)		
Management & Sys. Engr.	25	
Spacecraft	120	
Instruments	CRaTER	6.8
	Diviner	11.9
	LAMP	5.5
	LEND	5.1
	LOLA	19.7
LROC	17.3	
Launch Vehicle	90	
Ground Network/MOC & Mission Ops.	39	
I&T	11	
Reserve	56	
Total	407	

