

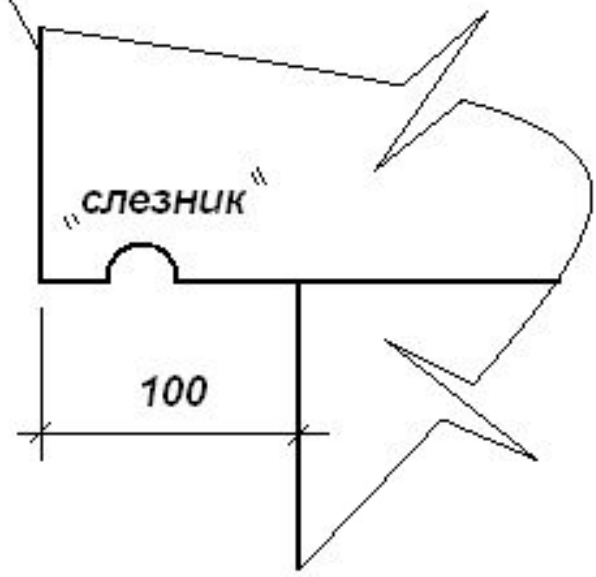

**НАЗНАЧЕНИЕ ОСНОВНЫХ РАЗМЕРОВ ОПОР
И ОПРЕДЕЛЕНИЕ НАГРУЗОК,
ДЕЙСТВУЮЩИХ НА ОПОРЫ**

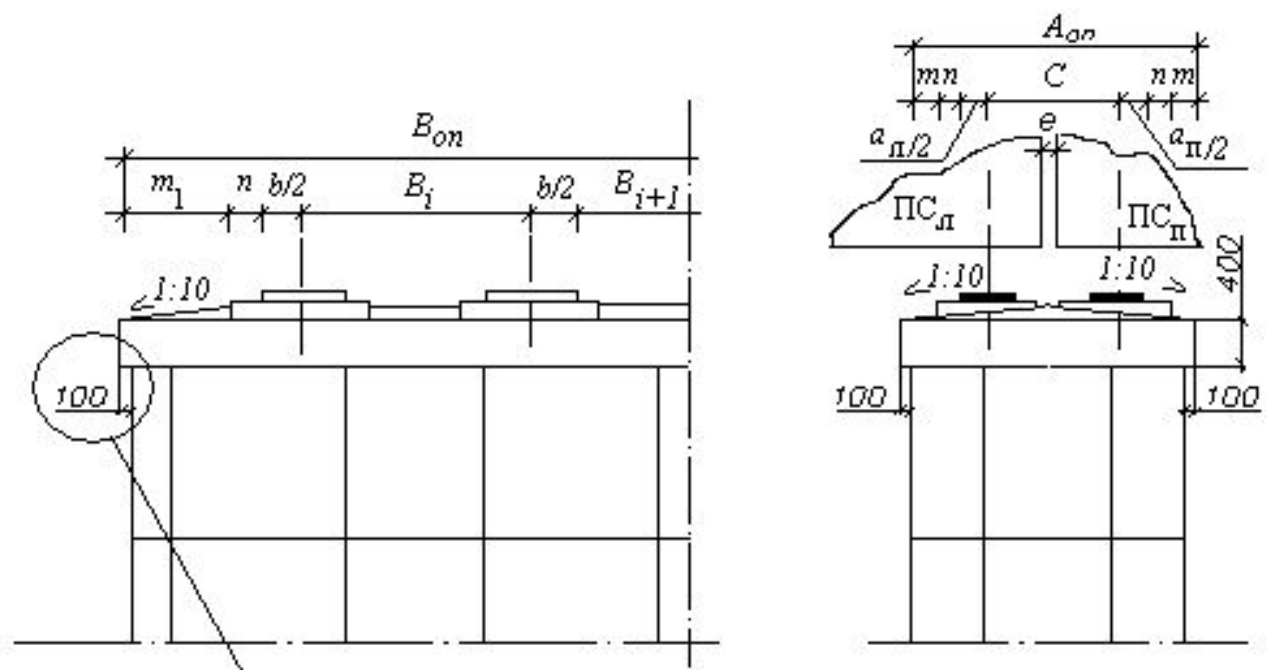

Резиновые слоистые опорные части для пролетных строений
по проекту инв. №384/43; 384/46; 384/47; 710/3

Пролетные строения		Марка по с/ртаменту			
		Р04		Р04 С	
		Обычное исполнение $t \geq -40^\circ\text{C}$		Северное исполнение $t \geq -55^\circ\text{C}$	
		$l \leq 0,005$	$l \leq 0,015$	$l \leq 0,005$	$l \leq 0,015$
Плитные пролетные строения $l=12,15,18$		15x35x4.0-0.5	15x35x4.0-0.5	15x35x4.0-0.5	15x35x4.0-0.5
Ребристые	12	15x35x4.0-0.5	15x35x4.0-0.5	15x35x4.0-0.5	15x35x4.0-0.5*
	15	15x35x4.0-0.5	15x35x4.0-0.5	15x35x4.0-0.5	15x35x4.0-0.5*
	18	15x35x4.0-0.5	15x35x4.0-0.5	15x35x4.0-0.5	15x35x4.0-0.5*
	21	15x35x4.0-0.5	15x40x4.7-0.5	15x35x4.0-0.5	15x40x4.7-0.5
	24	15x40x4.7-0.5	20x40x5.2-0.8	15x40x4.7-0.5	20x40x5.2-0.8
	33 $h=1.5$	20x40x5.2-0.8	30x40x7.8-1.0	20x40x5.2-0.8	30x40x7.8-1.0
	33 $h=1.7$	20x40x5.2-0.8	20x40x5.2-0.8	20x40x5.2-0.8	30x40x7.8-1.0
	42	30x40x7.8-1.0	30x40x7.8-1.0	30x40x7.8-1.0	30x40x7.8-1.0

Резиновые слоистые опорные части для пролетных строений
по проекту инв. №710/2; 710/5 (каркасных)

Пролетные строения		Марка по с/ртаменту			
		Р04		Р04 С	
		$t \geq -40^\circ\text{C}$		$t \geq -55^\circ\text{C}$	
		$l \leq 0,005$	$l > 0,005$	$l \leq 0,005$	$l > 0,005$
11.04; 12; 14.06; 15		25x20x3.2-0.8	25x20x3.2-0.8	25x20x3.2-0.8	25x20x3.2-0.8**
16.76; 18		25x20x6.2-0.8	25x20x6.2-0.8	25x20x6.2-0.8	25x20x6.2-0.8**

Примечания:

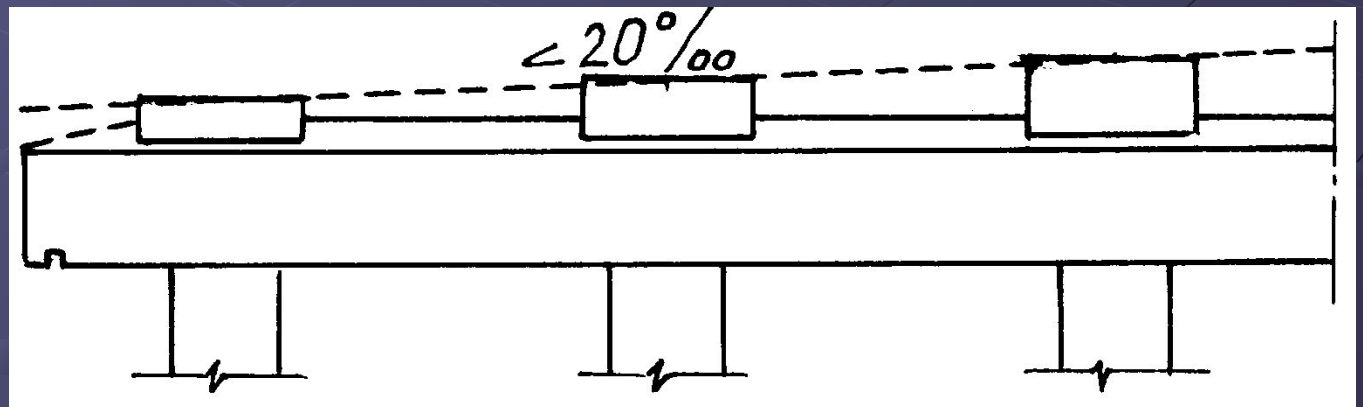
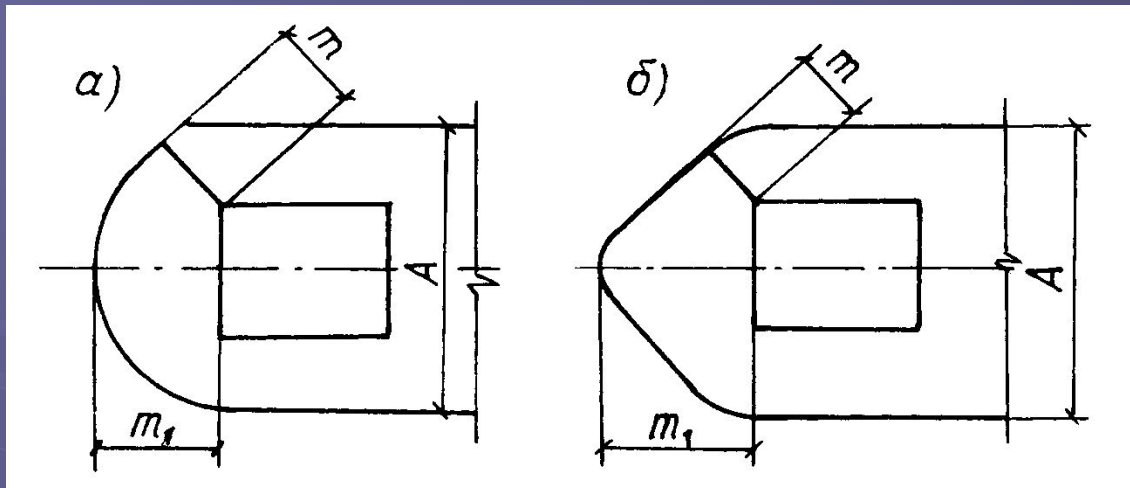

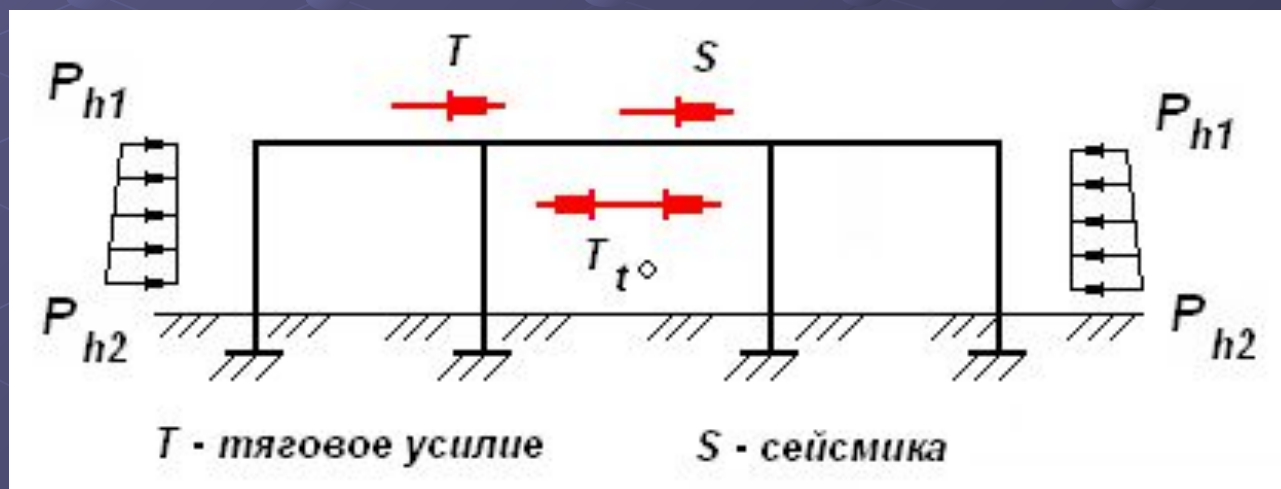
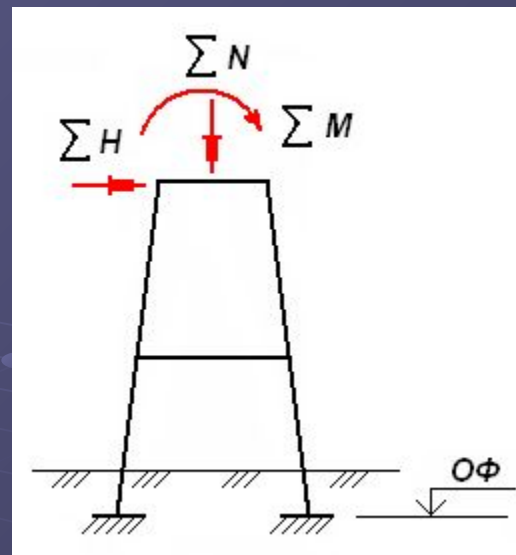
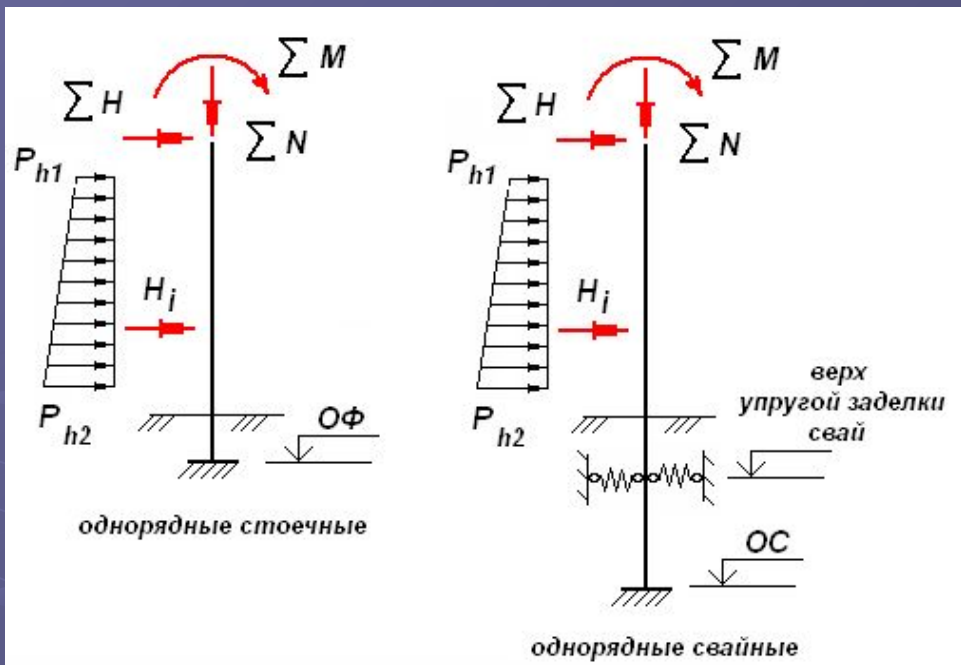

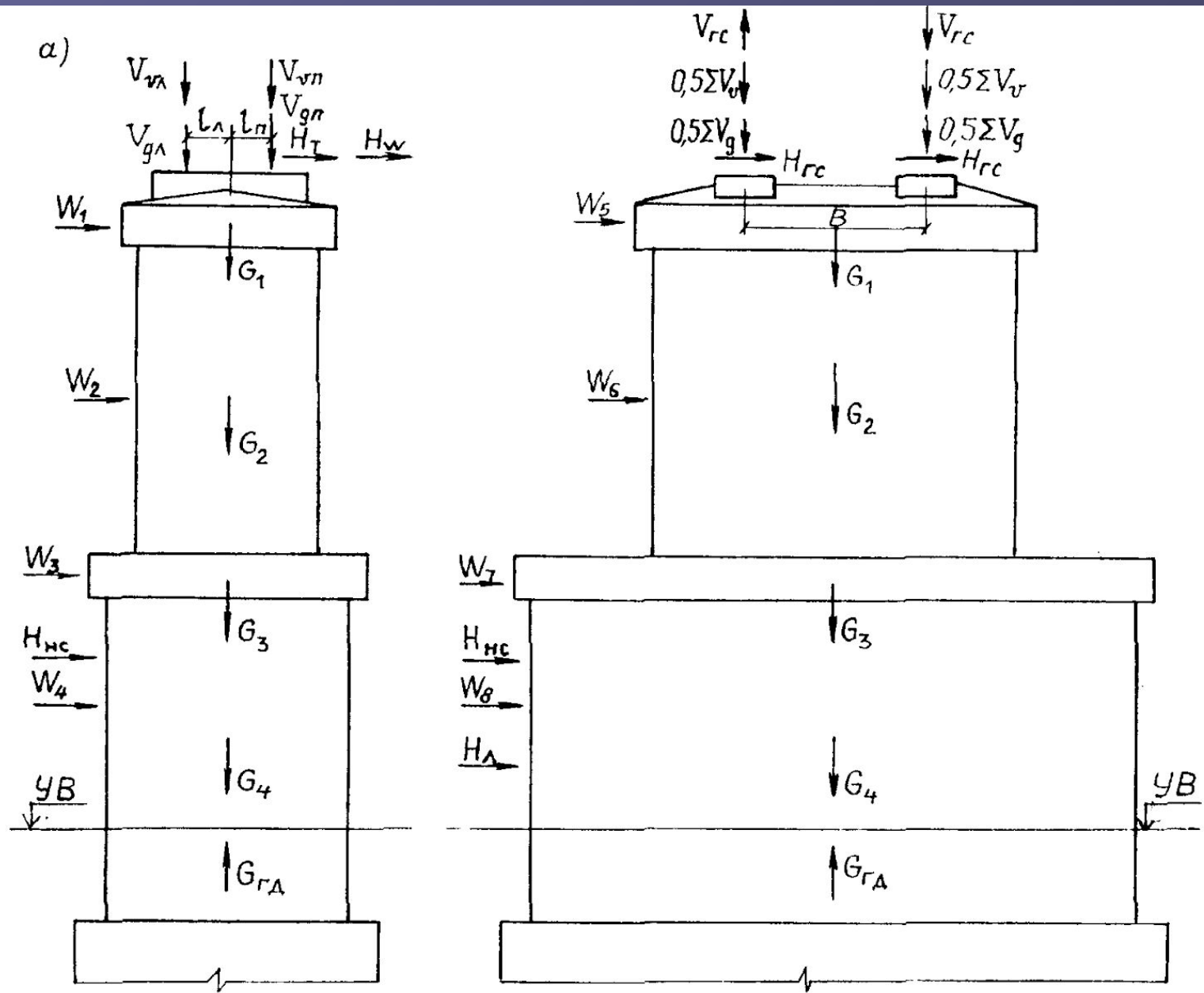

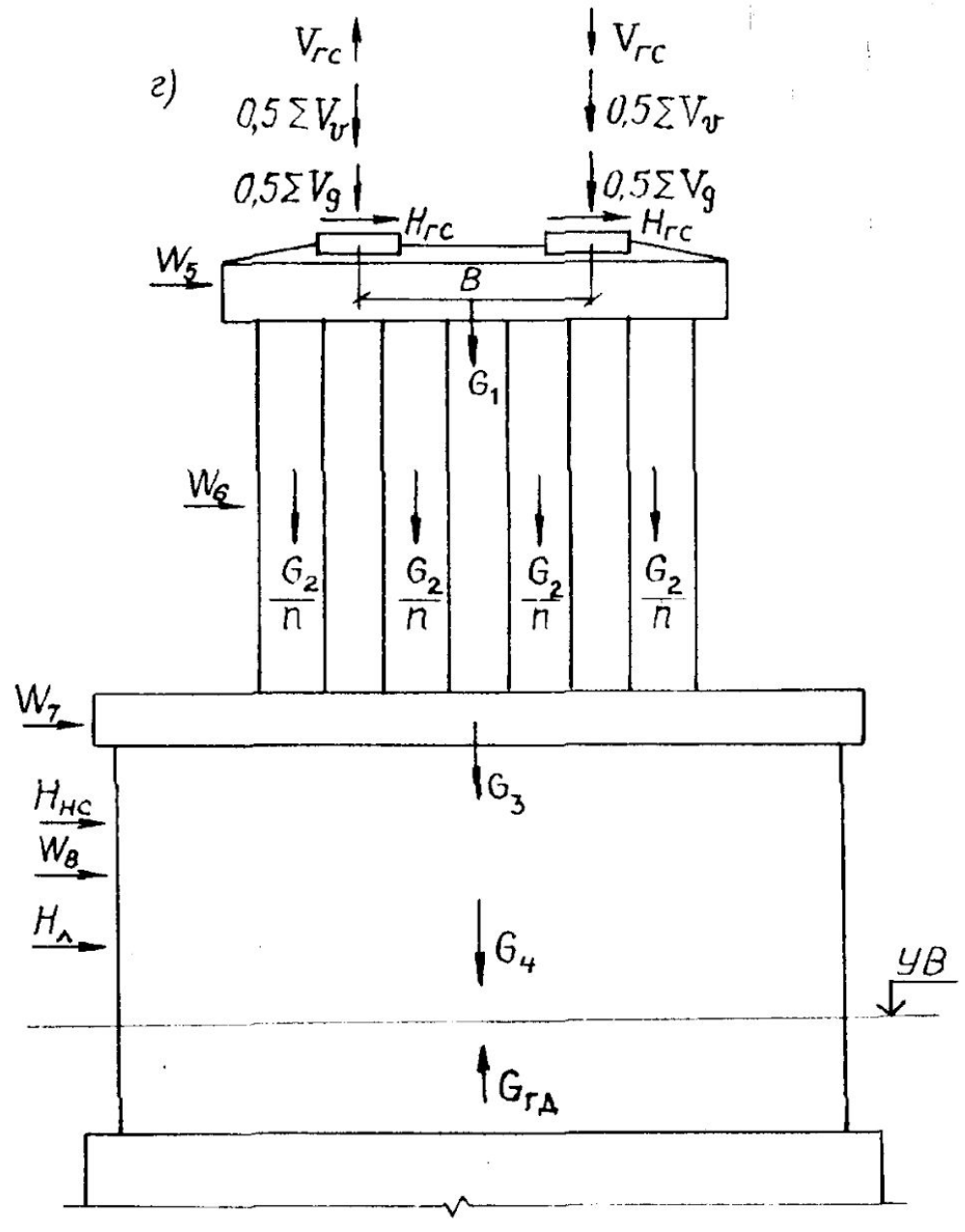
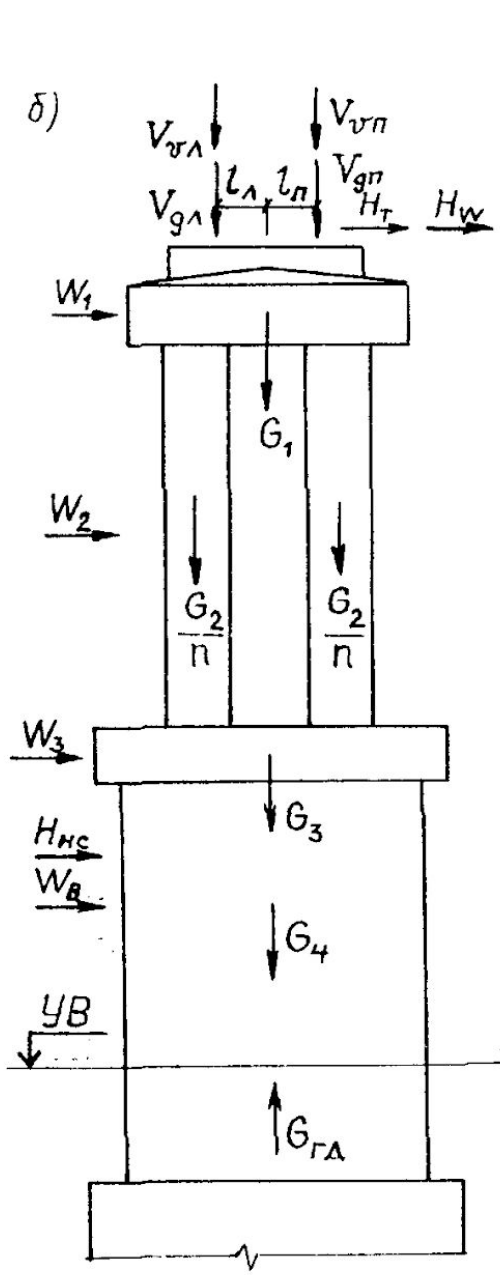

Ветровые районы, принимаемые по карте 3, Приложение Ж СНИП 2.01.07-85 «Нагрузки и воздействия»	Ia	I Алапаевск, Алдан, Каменск-Уральский, Мирный, Уренгой, Шадринск	II Барабинск, Братск, Киселевск, Куйбышев, Курган, Нефтеюганск, Омск, Прокопьевск, Свердловск, Сургут, Тобольск, Тюмень, Усть-Кут, Челябинск, Якутск	III Абакан, Анжеро-Судженск, Ачинск, Барнаул, Бийск, Енисейск, Игарка, Иркутск, Красноярск, Кемерово, Новосибирск, Норильск, Минусинск, Тайшет, Томск	IV	V	VI	VII
w_0 , кПа	0.17	0.23	0.30	0.38	0.48	0.60	0.73	0.85

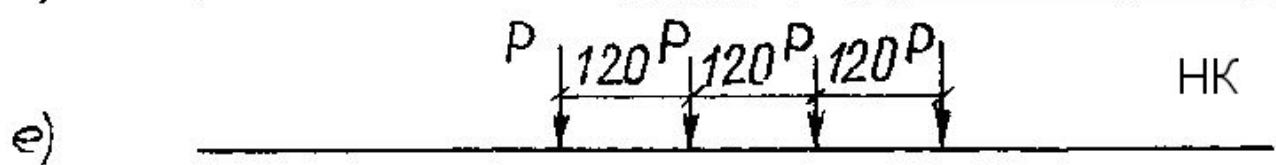
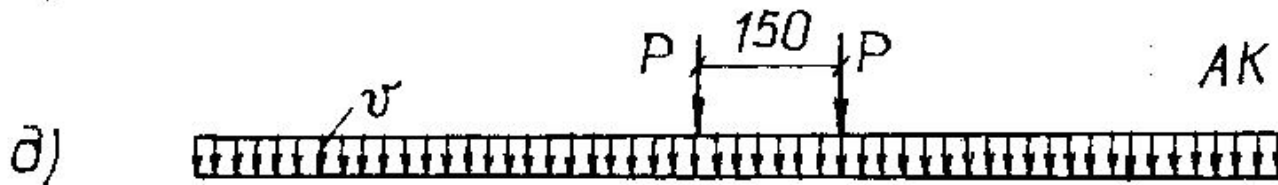
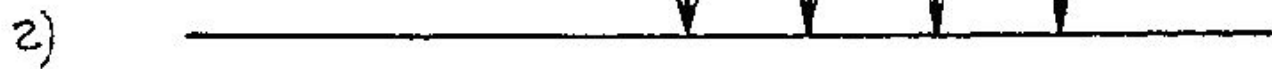
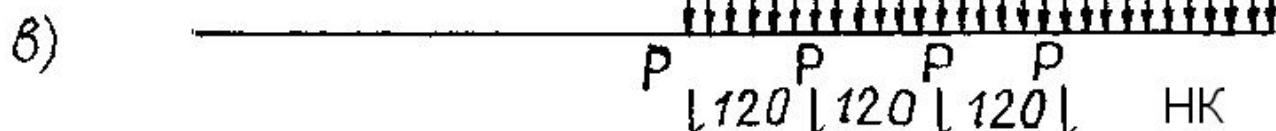
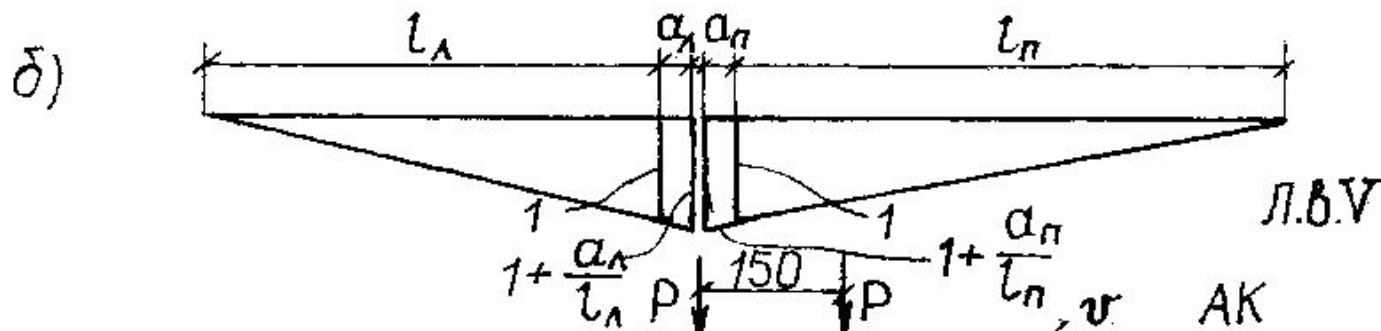
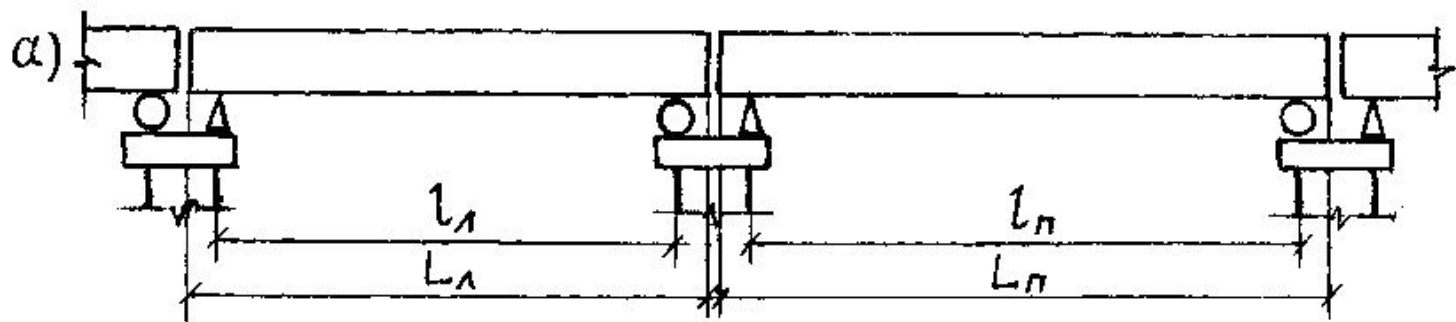

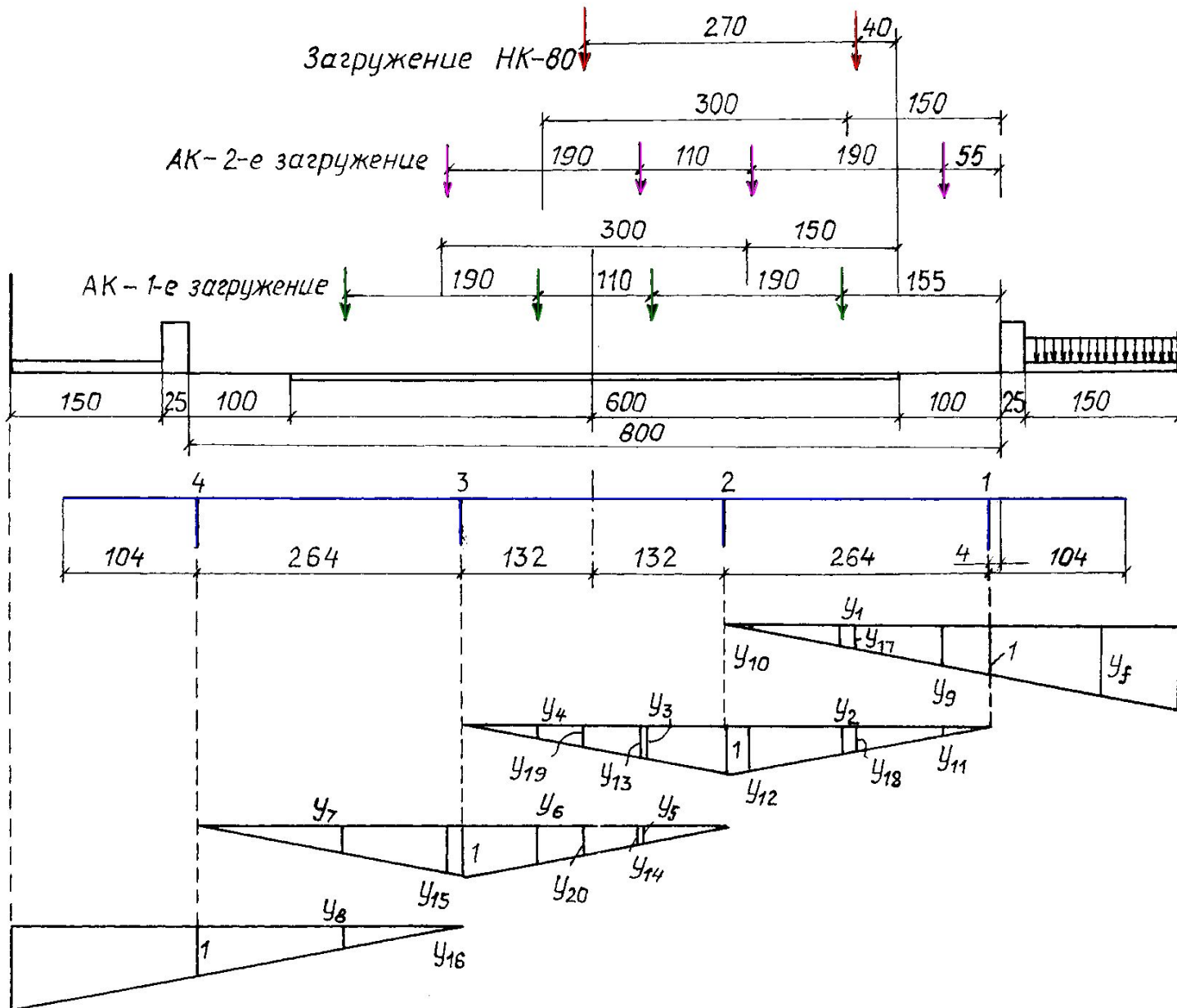

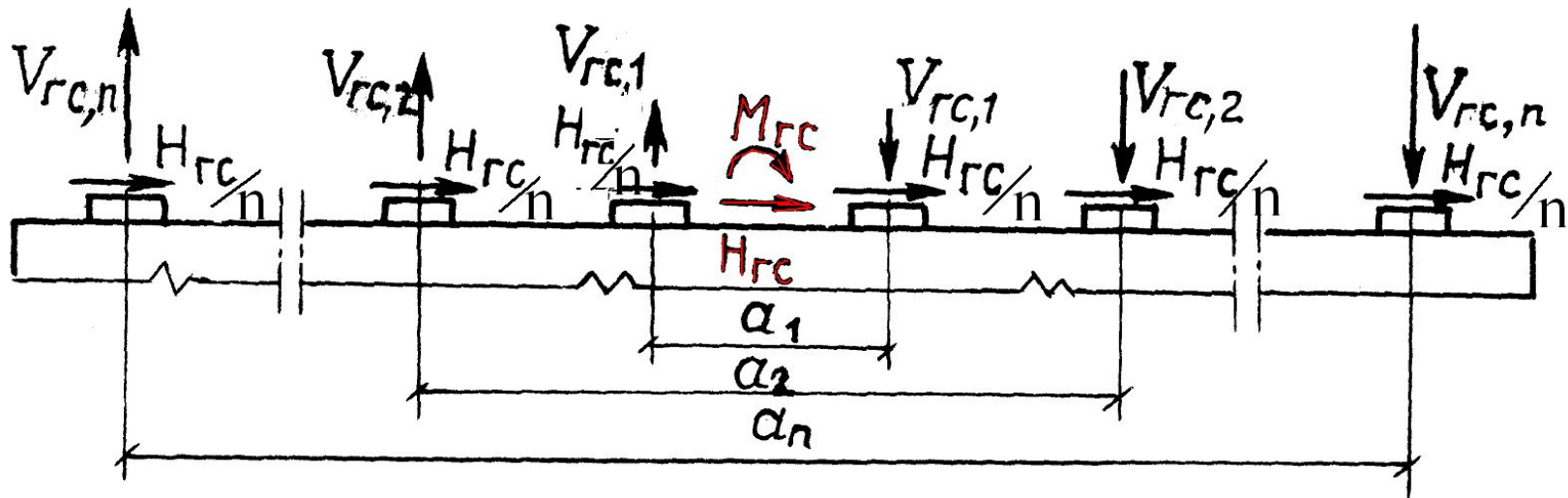

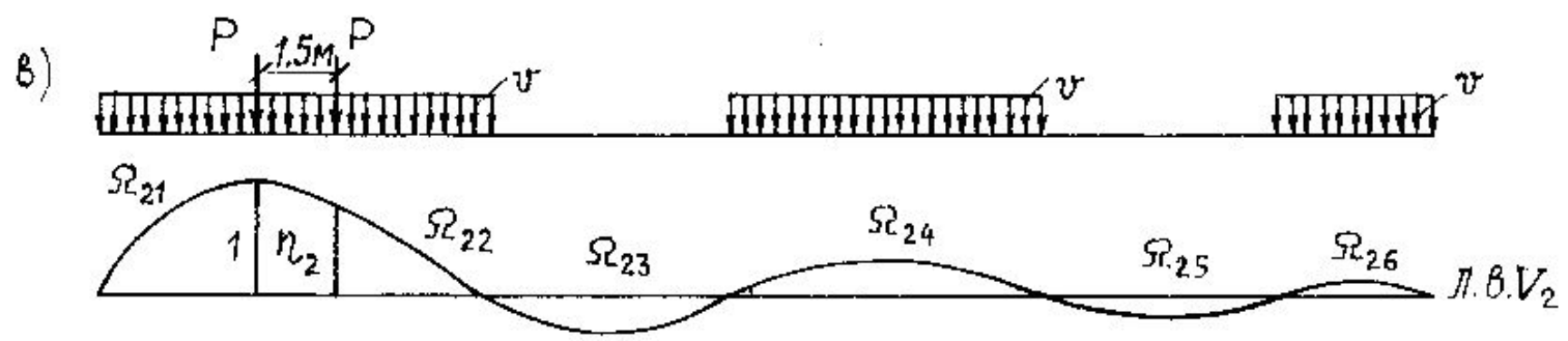
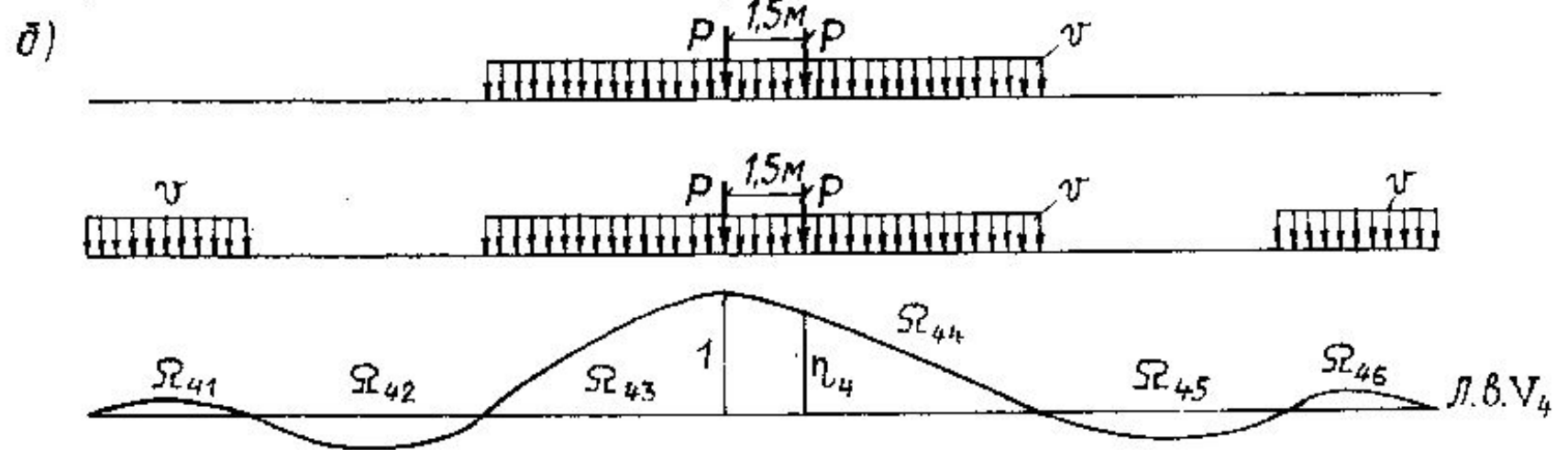
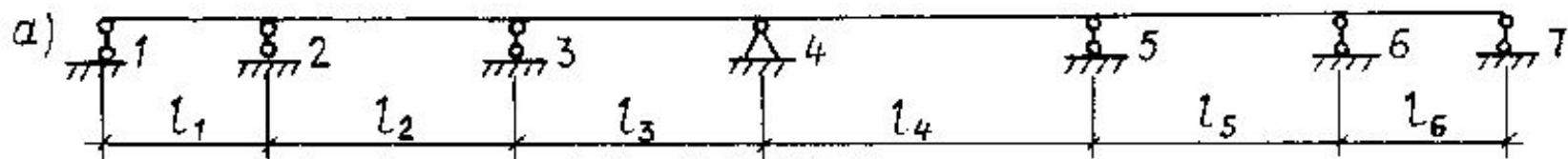

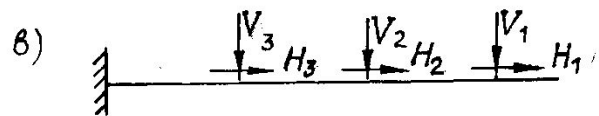
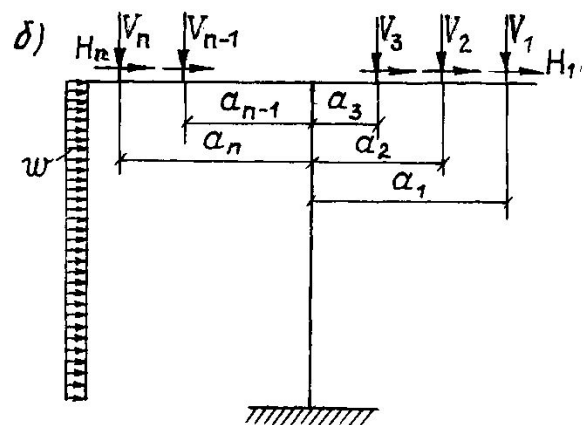
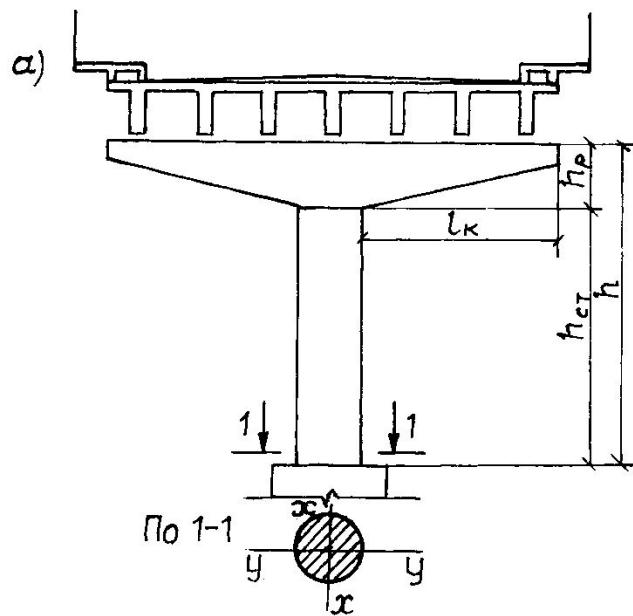

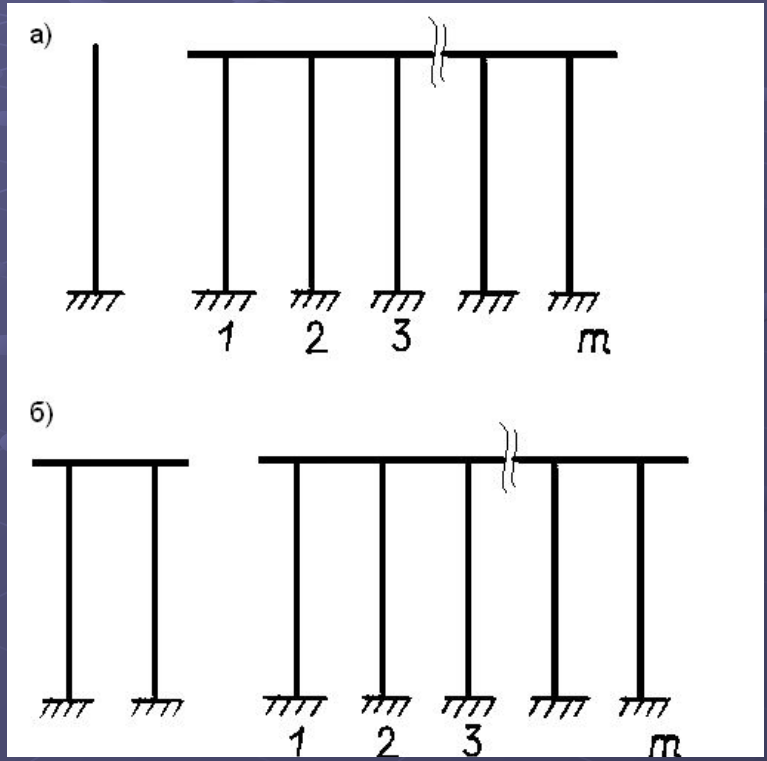

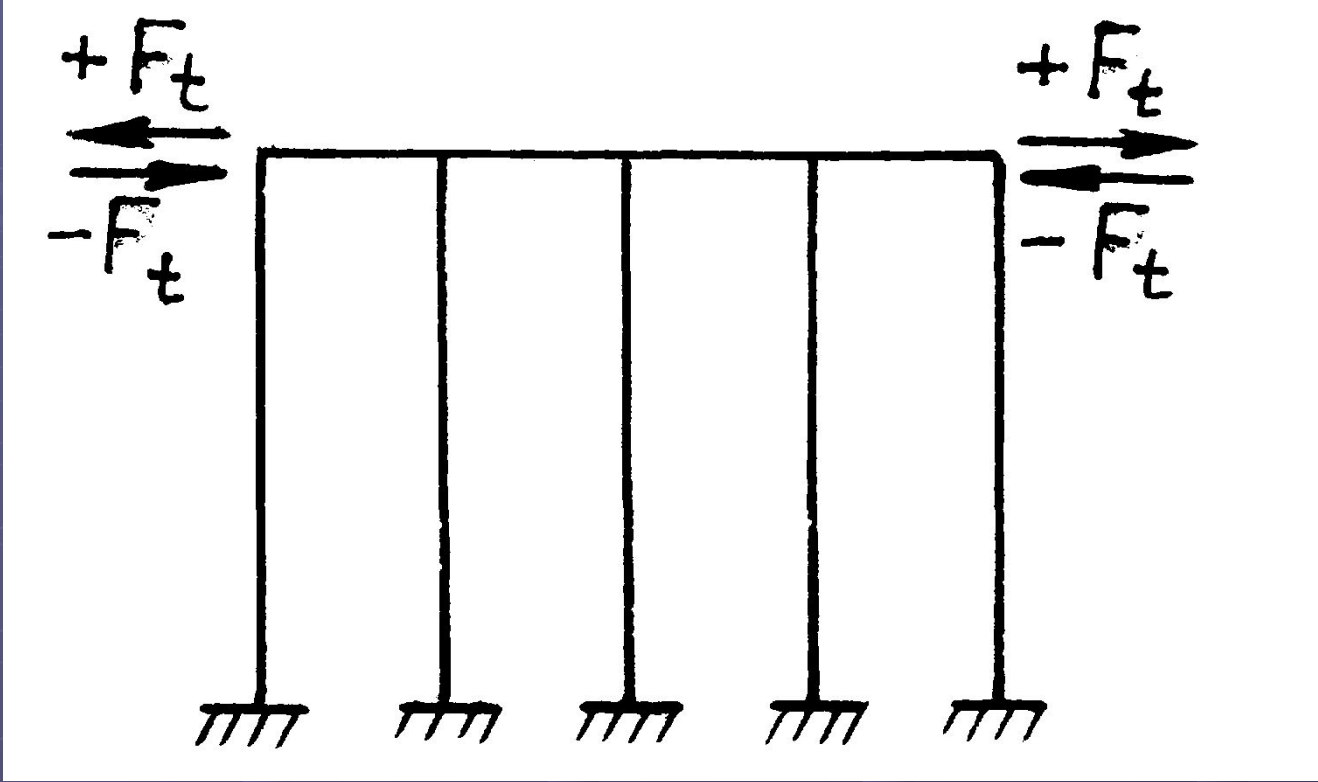

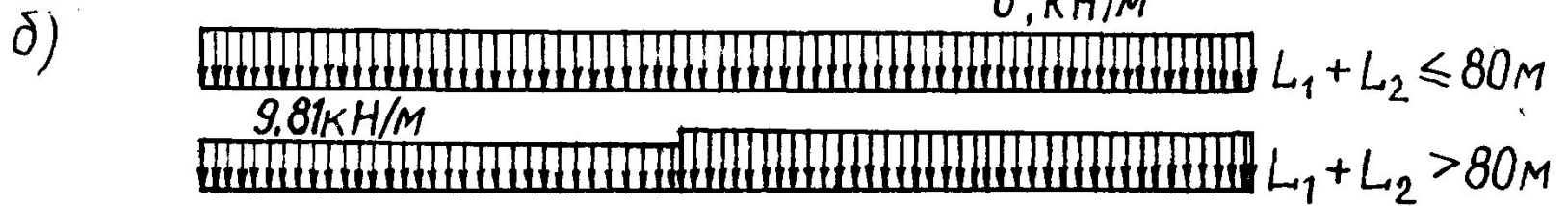
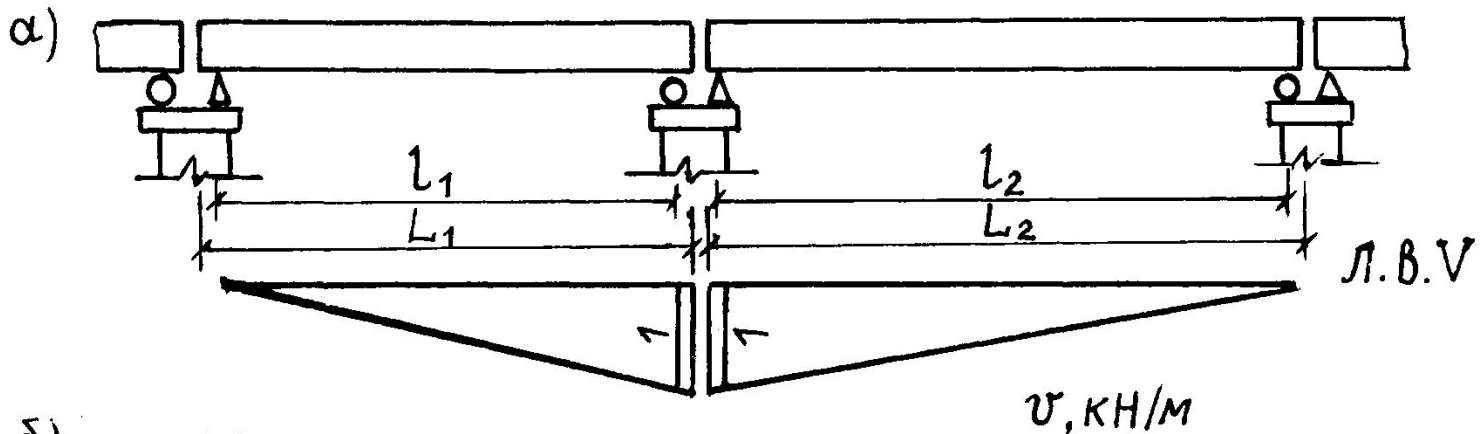

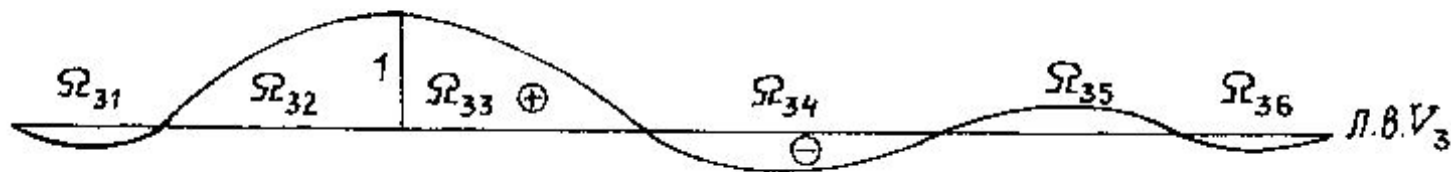
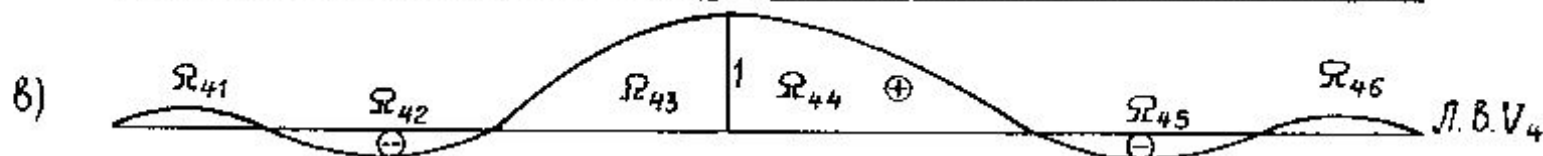
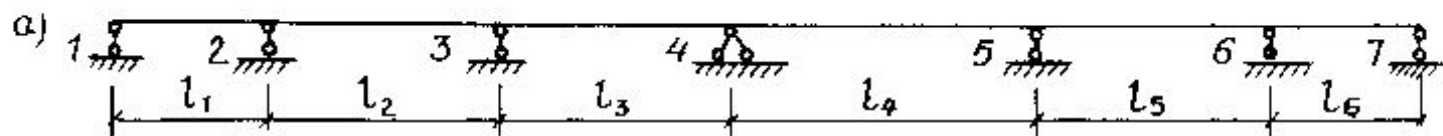

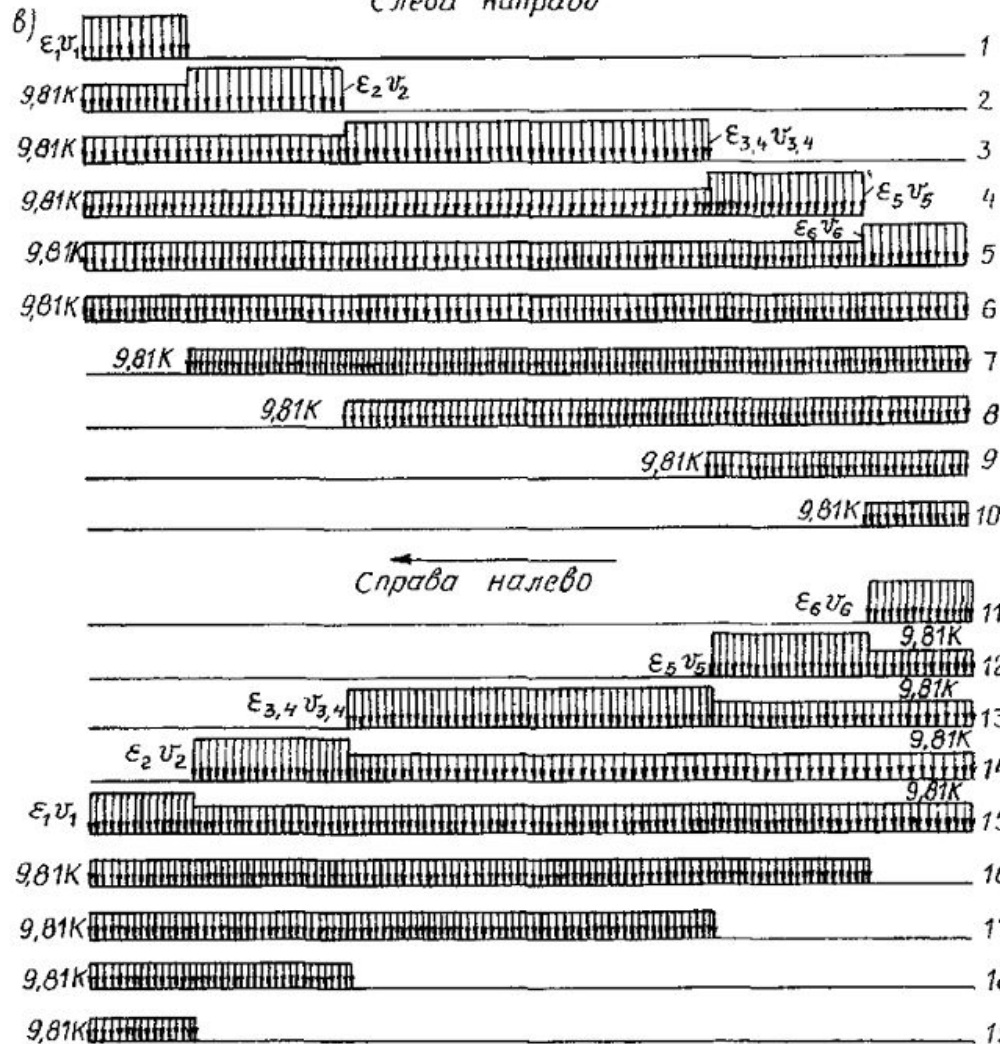
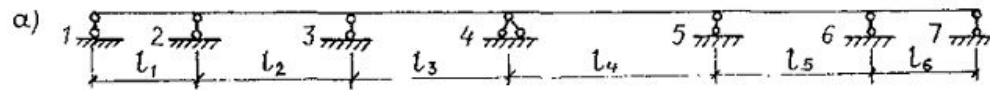

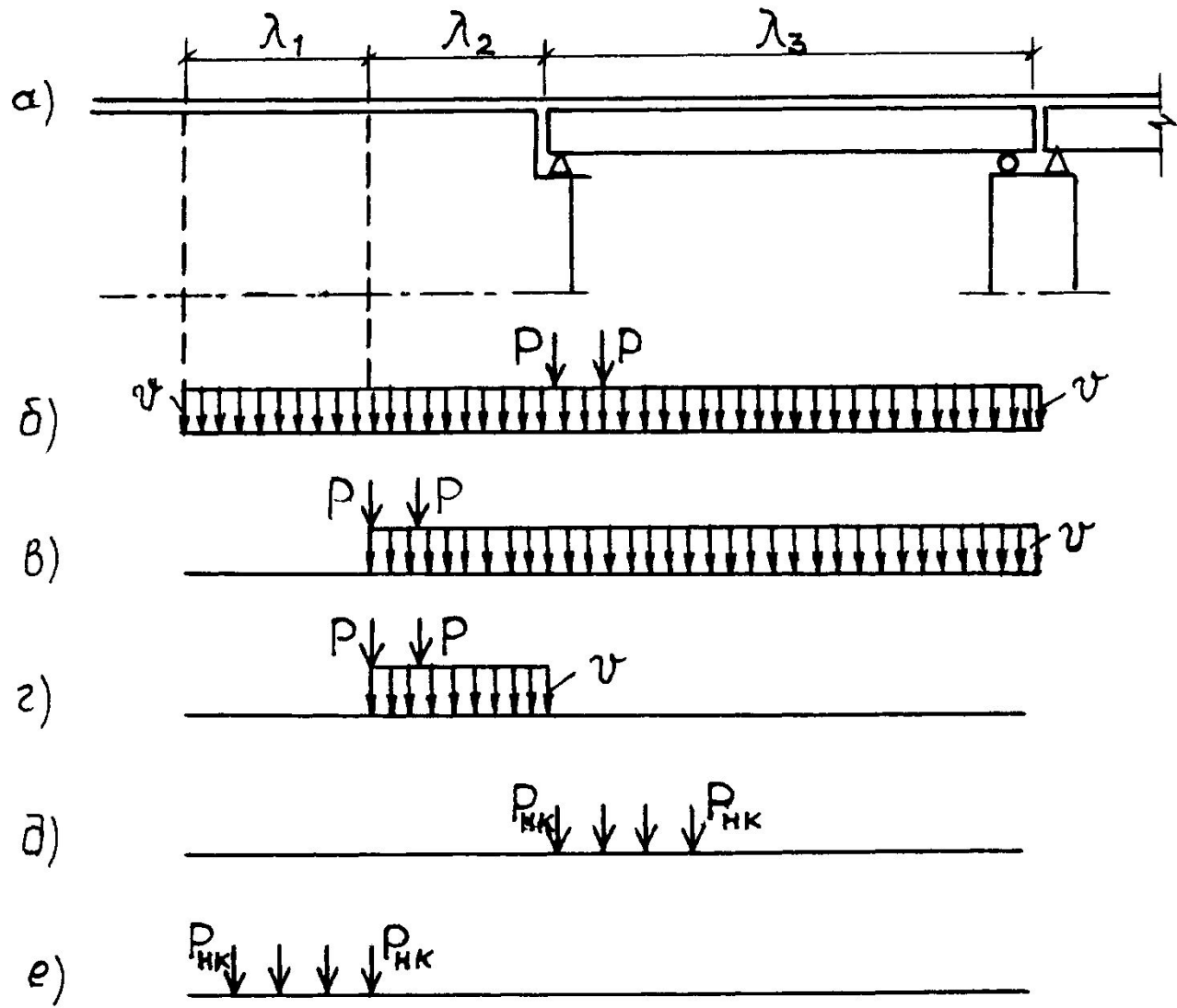

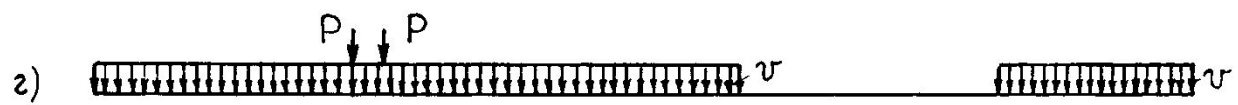
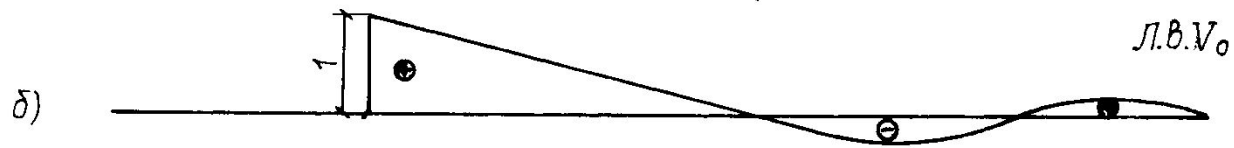
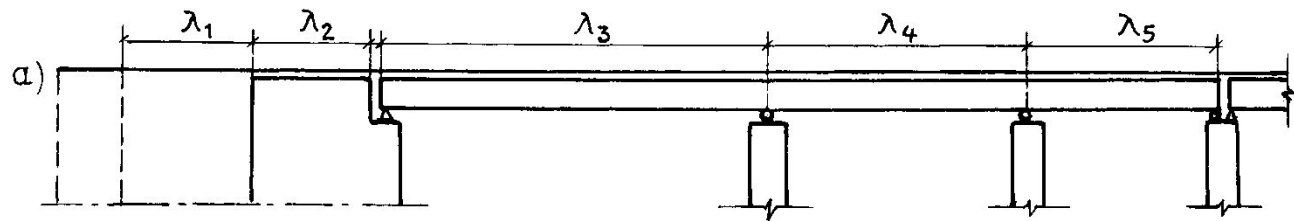

а) АК (ось тележки)

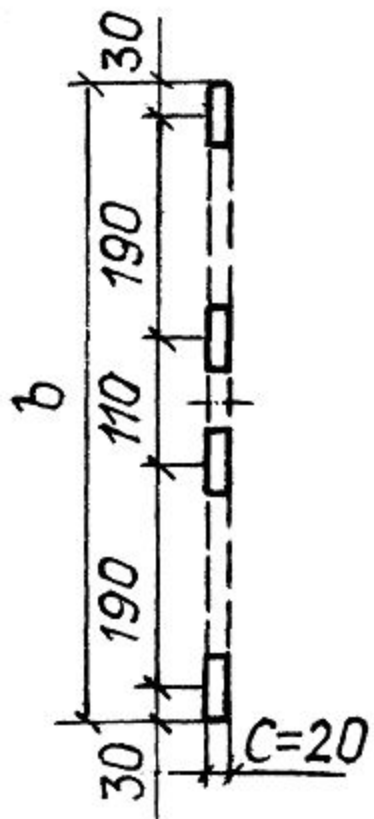

б) НК-80

