

# FIELD PROGRAMMABLE GATE ARRAYS

## Introduction

# What is a FPGA

## World of Integrated Circuits

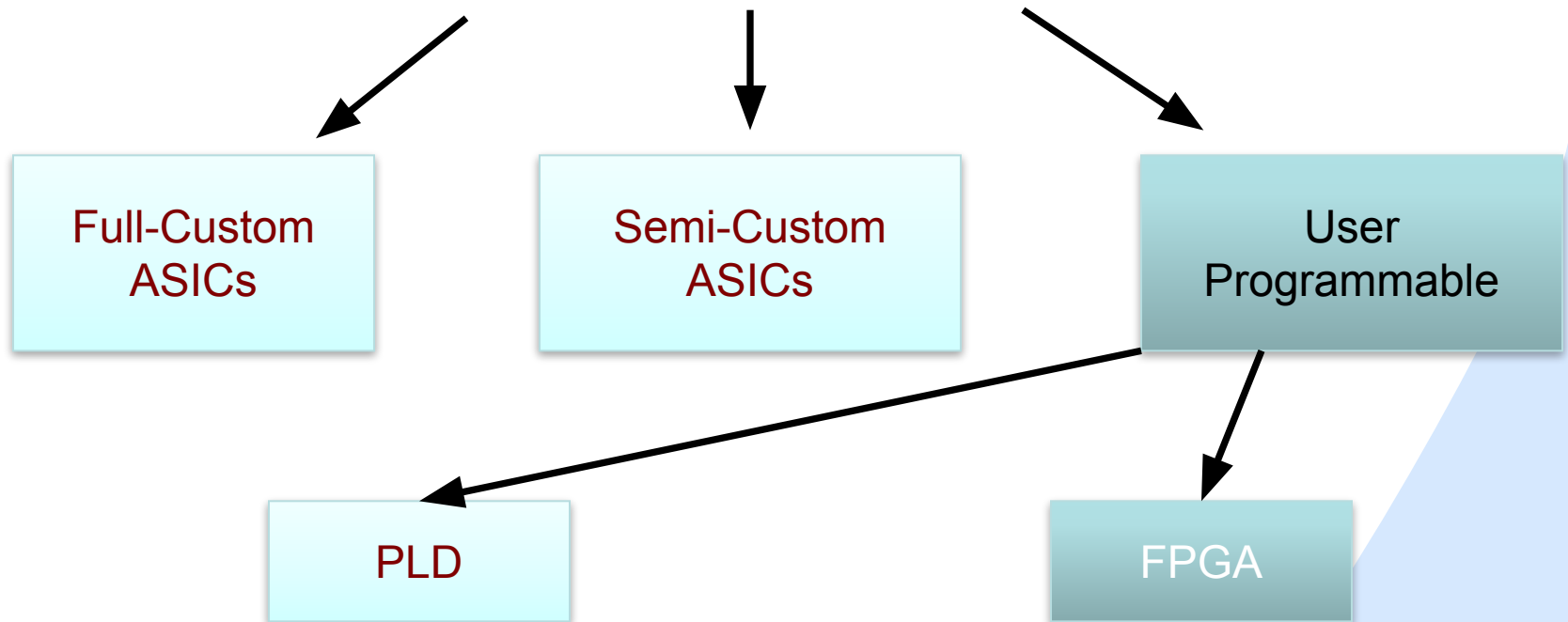

Field programmable gate arrays (FPGAs) – are digital integrated circuits that contain configurable blocks of logic along with configurable interconnects between these blocks.

# Why do we need FPGAs?

## ASICs

High performance

Low power

Low cost in  
high volumes

## FPGAs

Low development cost

Short time to market

Reprogrammable



# Other FPGA advantages

---

- Manufacturing cycle for ASIC is very costly, lengthy and engages lots of manpower
- Mistakes not detected at design time have large impact on development time and cost
- FPGAs are perfect for rapid prototyping of digital circuits
- Easy upgrades like in case of software
- Unique applications

# Architecture of FPGA

---

The architecture of FPGA is very simple than other programmable devices

## Elements of FPGA

The basic elements of an Field Programmable Gate Array are:

- Configurable logic blocks(CLBs)
- Configurable input output blocks(IOBs)
- Two layer metal network of vertical and horizontal lines for interconnecting the CLBS and FPGAs (programmable interconnect)

# Architecture of FPGA

A simple modern architecture of FPGA is shown below:

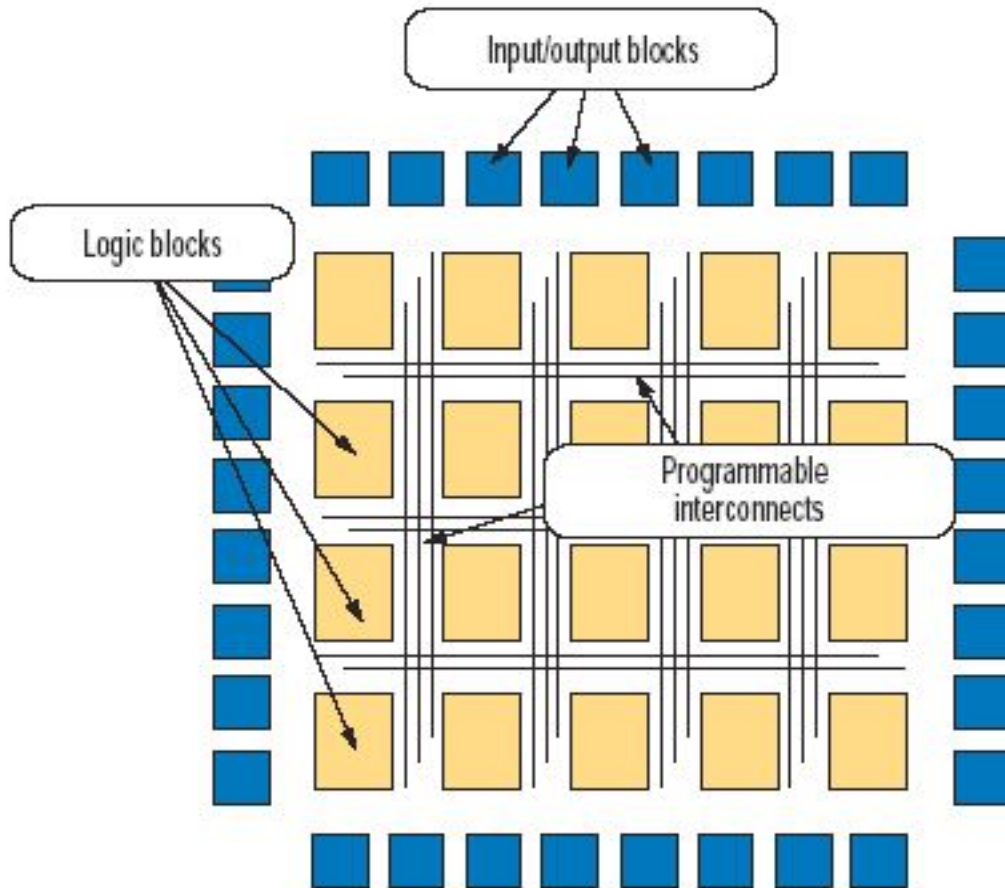

All FPGAs include a regular, programmable, and flexible architecture of logic blocks surrounded by input/output blocks on the perimeter. These functional blocks are linked together by a hierarchy of highly versatile programmable interconnects.

# A simple programmable function

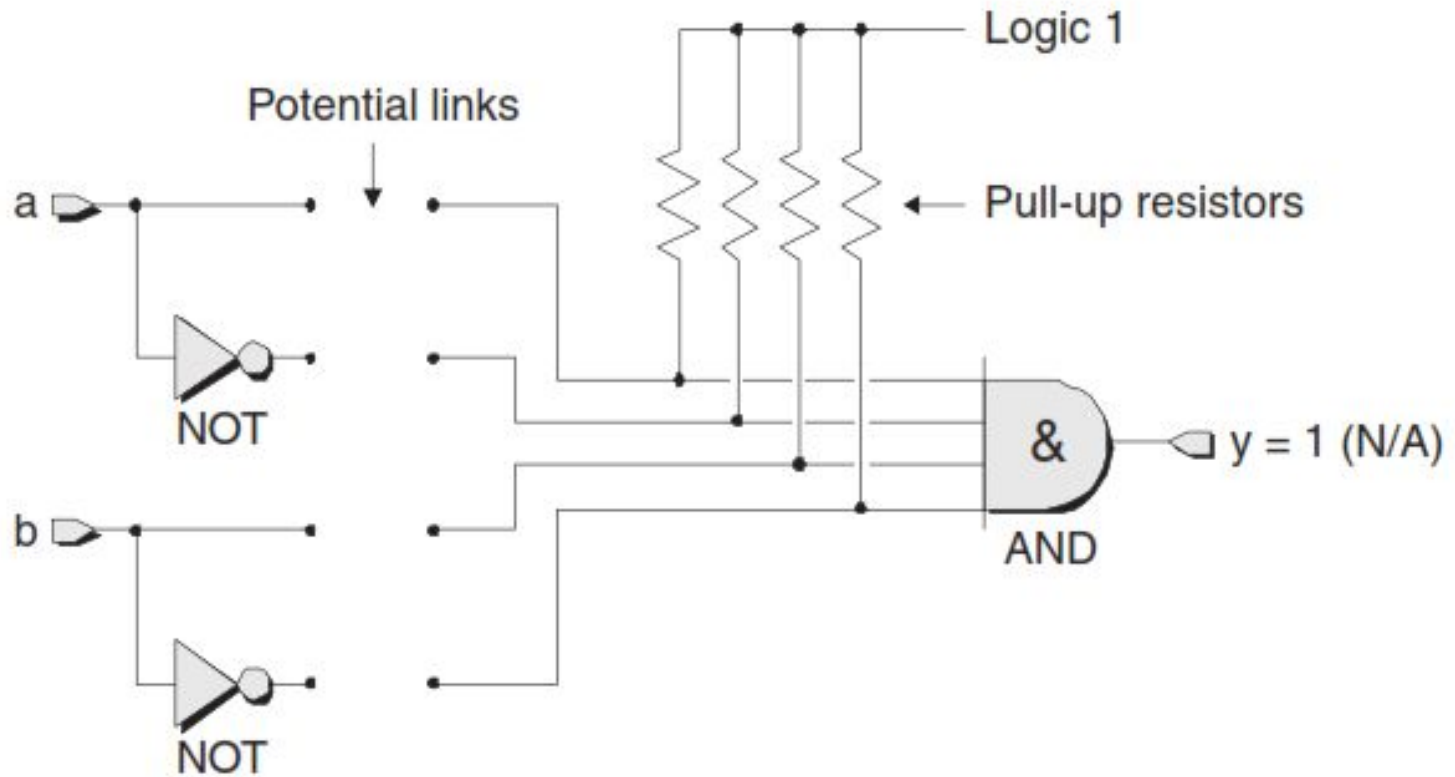

# Technology of program logic devices

## Fusible link technologies

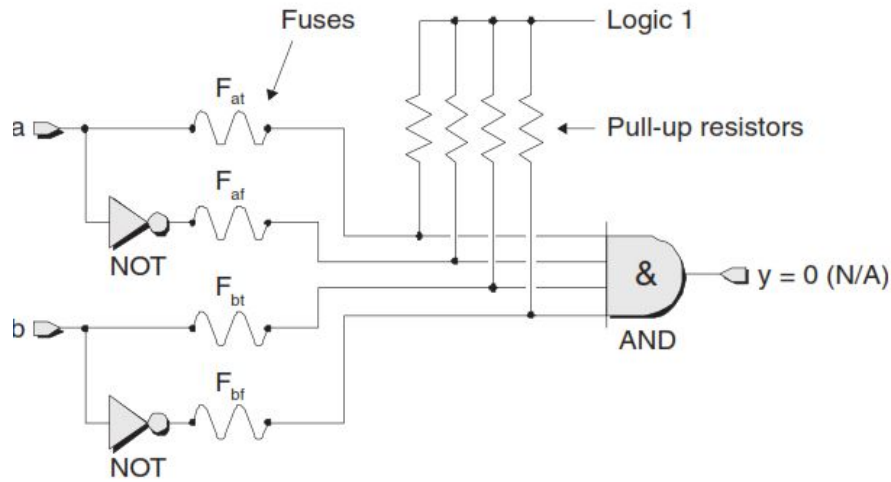

Unprogrammed fusible links

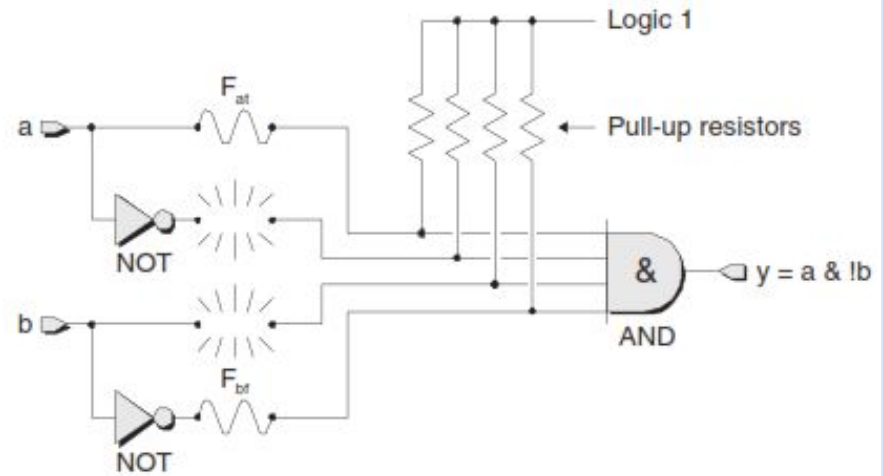

Programmed fusible links



# Technology of program logic devices

## Antifuse technologies

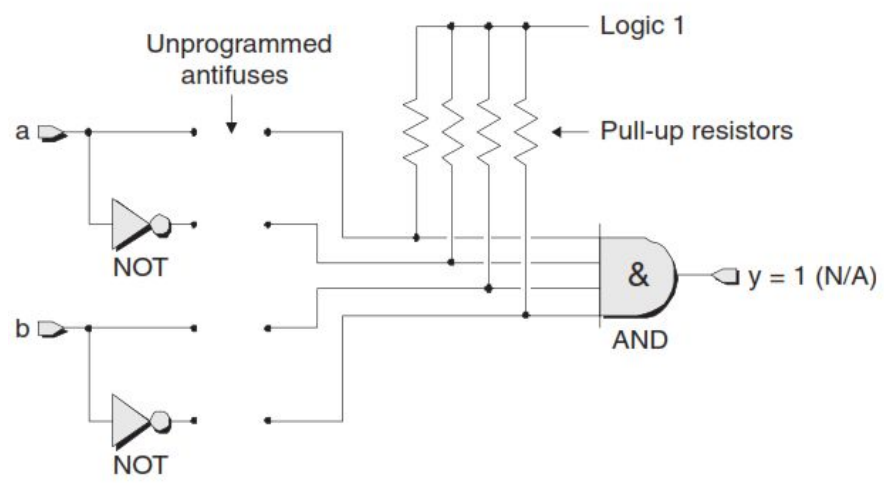

Unprogrammed antifuse links

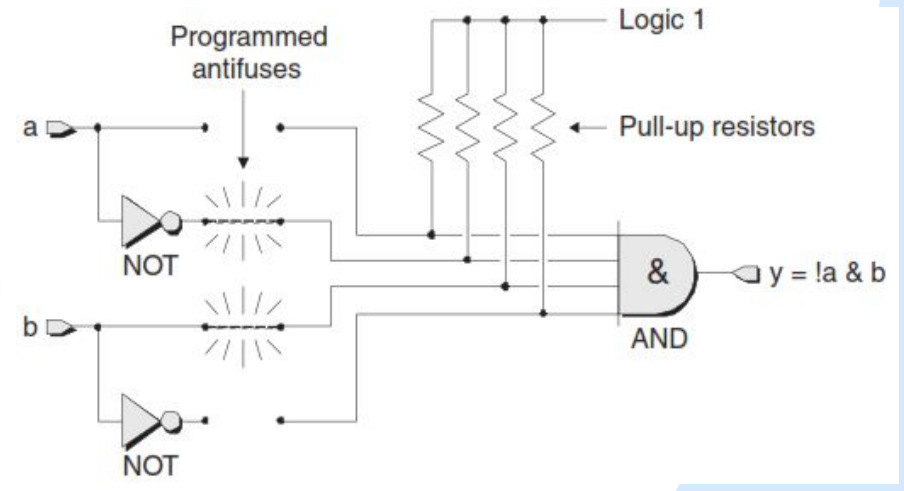

Programmed antifuse links

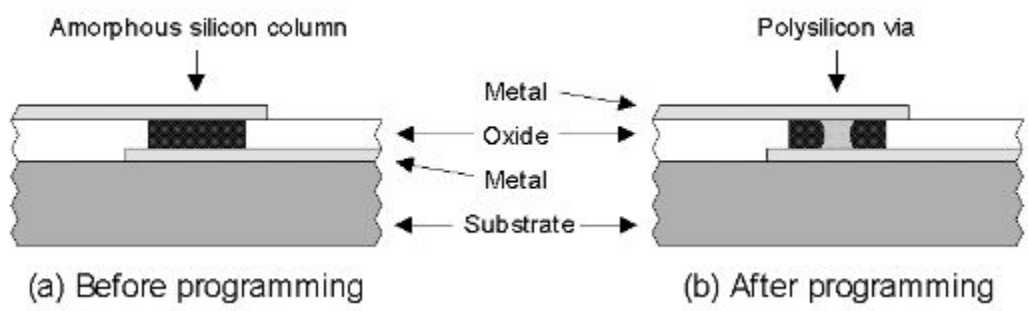

The act of programming particular element effectively grows a link by converting the insulating amorphous silicon into conducting polysilicon

# Physical principles of logic block configuration

## Mask-programmed devices

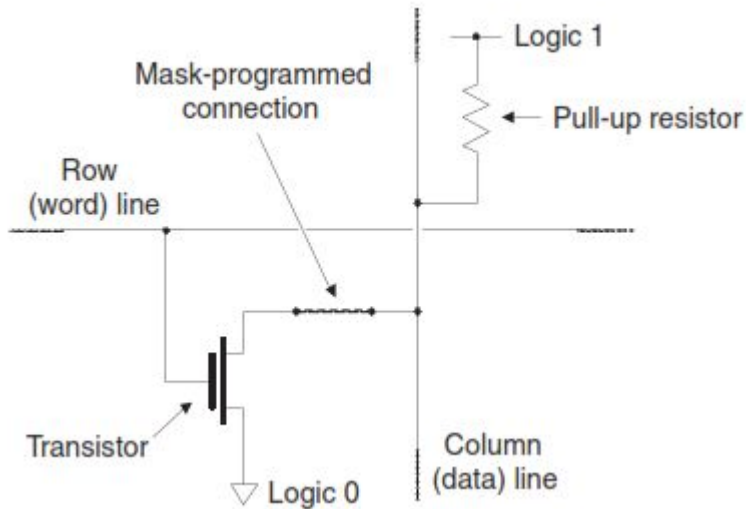

A transistor-based mask-programmed ROM cell

- creating is a very expensive
- little used in a development environment in which often need to modify contents

## Programmable read-only memory PROMs

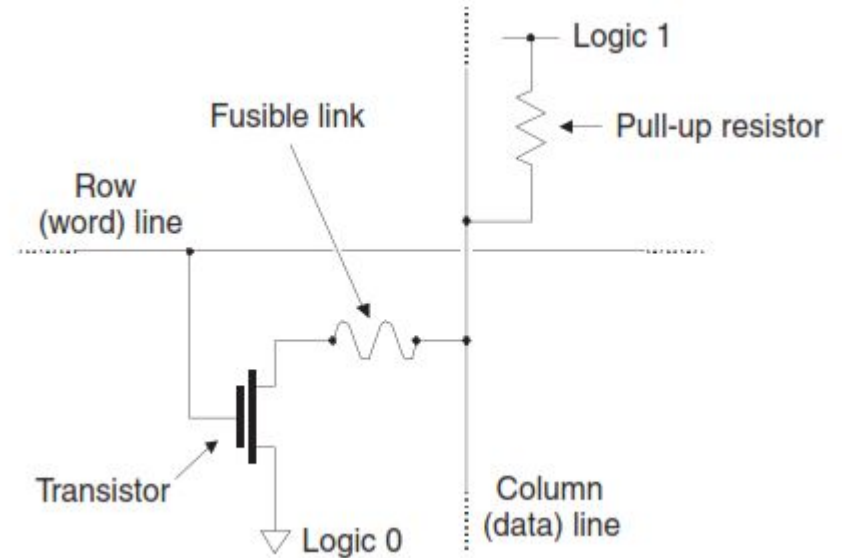

A transistor-based PROM cell

- intended for use as memories to store computer programs
- could be used to fix bugs or test new implementations

# Physical principles of logic block configuration

## □ EPROM-based technologies

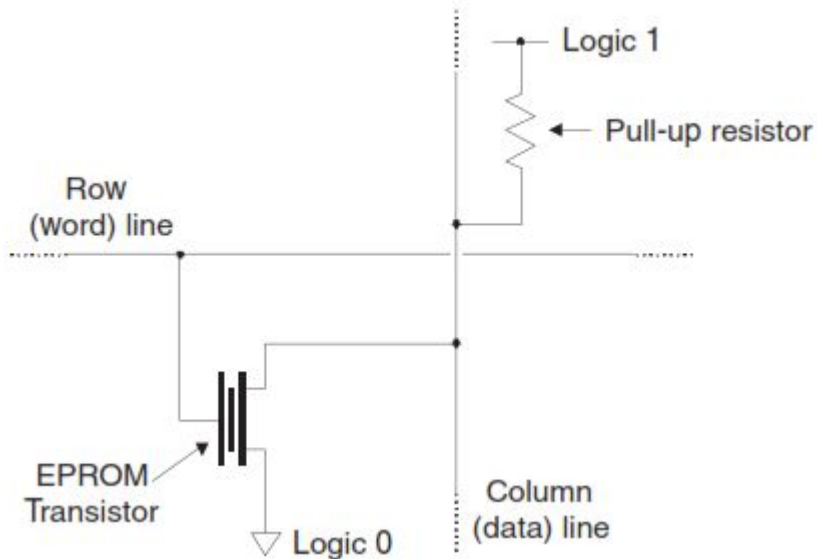

An EPROM transistor-based memory cell

- expensive packages with quartz windows and the time takes to erase
- use as a programmable memories

## □ EEPROM-based technologies

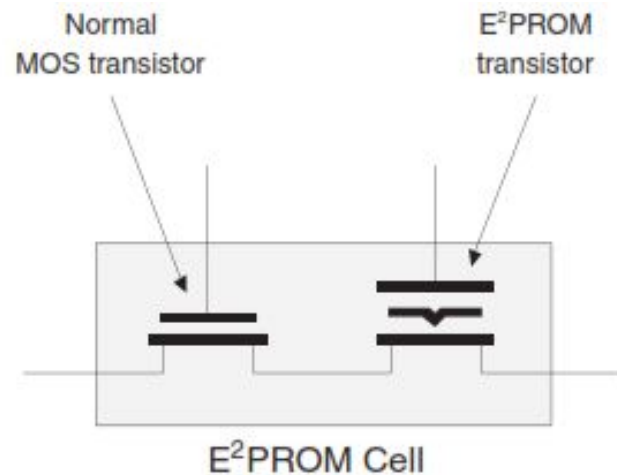

An EEPROM-cell

- EEPROM transistor contains a floating gate, but the insulating oxide layers surrounding this gate are very much thinner
- the second transistor can be used to erase the cell electrically

# Physical principles of logic block configuration

## SRAM-based technologies

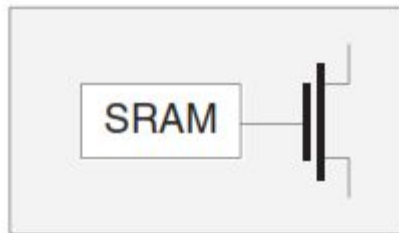

An SRAM-cell programmable cell

- fast re-programmability
- standard IC fabrication technologies is used
- requires large area



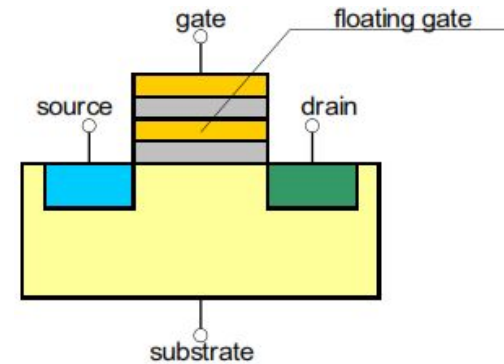

## Flash-based technologies

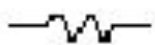

A floating-gate transistor used in flash memory

- electrically erased
- less power
- tolerant to radiation effect

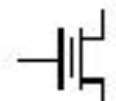
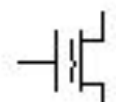
# Summary of programming technologies

| Technology                    | Symbol  | Predominantly associated with ... |
|-------------------------------|---|-----------------------------------|
| Fusible-link                  |    | SPLDs                             |
| Antifuse                      |    | FPGAs                             |
| EPROM                         |    | SPLDs and CPLDs                   |
| E <sup>2</sup> PROM/<br>FLASH |   | SPLDs and CPLDs<br>(some FPGAs)   |
| SRAM                          |  | FPGAs (some CPLDs)                |