

Мүсін өнері



Сабақтың мақсаты:

Мүсін өнерінің түрлерімен таныстыру.
Мүсіншілердің көркем шығармаларын талдау. Мүсін сомдау материалдарының технологиялық тәсілдерімен таныстыру. Әр түрлі материалды ұқыпты пайдалана білуге үйрену арқылы эстетикалық тәрбие беру. Саз балшықтан немесе ермексаздан созу, ию тәсілдерін терең меңгеру.



Монументті мүсін және рельефті мүсін.



Хакімжан Наурызбаев
(1925-2009ж.ж) Қазақстан
монументті мүіінің негізін
қалаушысы



Х.Наурызбаев “Абай Құнанбаев” 1960 ж



Х.Наурызбаев “Ш. Уәлиханов” 1969 ж



Х.Наурызбаев “Ж.Жабаев”



Т.Досмағамбетов “Барыс”



Е.Сергебаев “Абай мен Пушкин”



Д.Г. Эльбакидзе “Ш. Уәлиханов пен Ф.Достоевский” (Қола)



Д.Г. Эльбакидзе “Абай”



Қоладан жасалған тыйын (рельефті мүсін)



Қабырғаға орындалған рельевті мүсін.



Ғ.Мүсірепов атындағы жастар драма театры.



Мүсін сомдауға арналған материялдар



Мүсінмен айналысқанда қолданылатын негізгі құралдар

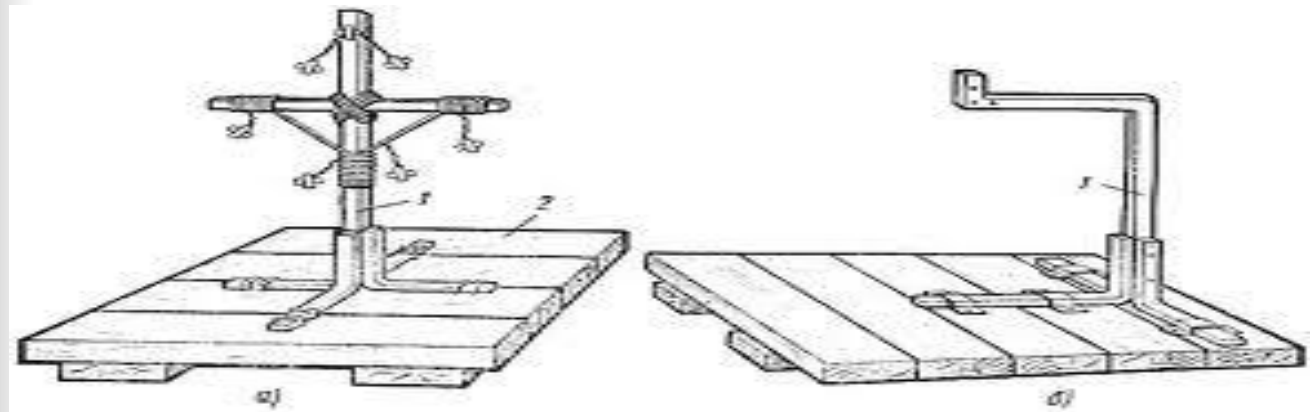



- Мүсін өнерінің түрлері қандай?
- Астана қаласындағы “Барыс” ескерткішінің авторы кім?
- Мүсін сомдаудағы негізгі материал?
- Мүсінмен айналысқанда қандай құралдар қолданылады?