



**The Russian Ministry of Education and Science
The Federal State Education Institution of Higher Education
" Astrakhan State University "**

Srtem 35.04.06 «Agroengineering»

EDX eSeed precision air seeder

**Students fulfill the grop DAI-31:
Bagiryay B.A.**

Astrakhan 2016

Short abstract:

The electrical power to drive the systems on the EDX eSeed precision air seeder is supplied via the high voltage system (“High Voltage”) of the tractor. Via TIM (Tractor Implement Management) the control electronics on the tractor are accessed. The implement controls itself through its own intelligence and makes use of the two most current and modern technologies
in the range of ISOBUS for further improvement and efficiency of the machine.



EDX eSeed



EDX eSeed – detailed view 230 V metering servo-motor

In contrast to the normal EDX, the drive systems for the blower fan and metering on the EDX eSeed have been replaced by high voltage motors (400 V) and are accessed via the power inverters on the tractor. The metering drive systems have been replaced by efficient servo-motors with clearly improved dynamics.

On large pneumatic seed drills, the blower fans are hydraulically driven, an arrangement which offers a high degree of flexibility but, due to poor efficiency results in high fuel consumption. More and more comfort functions mean that the electric 12 V systems on usual tractors meet their limits.

Hydraulics of the new system are only needed for the actuation of hydraulic rams, for example when folding. An additional advantage of the system is the independence from the engine speed of the tractor so that it is possible to operate the tractor at its optimum fuel consumption.



Detailed view 400 V fertiliser blower fan

Electric drive systems

Electric drive systems - that drive system, of dynamic illumination to draw, high precision in the spatial ripple optimum speed control and homogeneity and high quality.

This system, take-off and moment, speed and n adopted with required accuracy and of recent.

Electric drive systems made of a motor, the reference position and enterprise content management , that have 3 parameter is enabled only for control : position, speed , current.

The appointment Electric drive systems - controls its speed, , of the torque and for machine parts components mechanisms .

As displacement, angle and fast control of moment and speed effected by feedback or closed loop techniques with automatic setting function for real time, to prevent disappearances excellent dynamic performance.



Electric drive systems

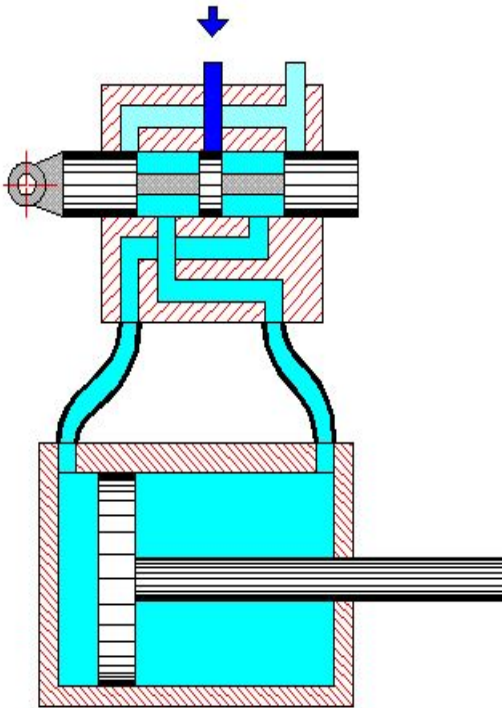

The scheme 1. Hydraulic drive

Thanks to the electric drives?
the efficiency of the total system is
clearly
improved. On hydrostatic drive systems
a mechanical efficiency of 60 % is
anticipated.

With an electrical system today, more
than
85 % is achieved. 20 kW, consumed as
mechanical power, requires
approximately 33.3 kW drive capacity
in a hydraulic system, whereas in an
electric drive line only approximately
23.5 kW are necessary. Here alone, fuel
savings of up to 50 l of diesel per day
are possible.

The scheme EDX eSeed precision air seeder and implementing Tractor-Implement-Management (TIM)

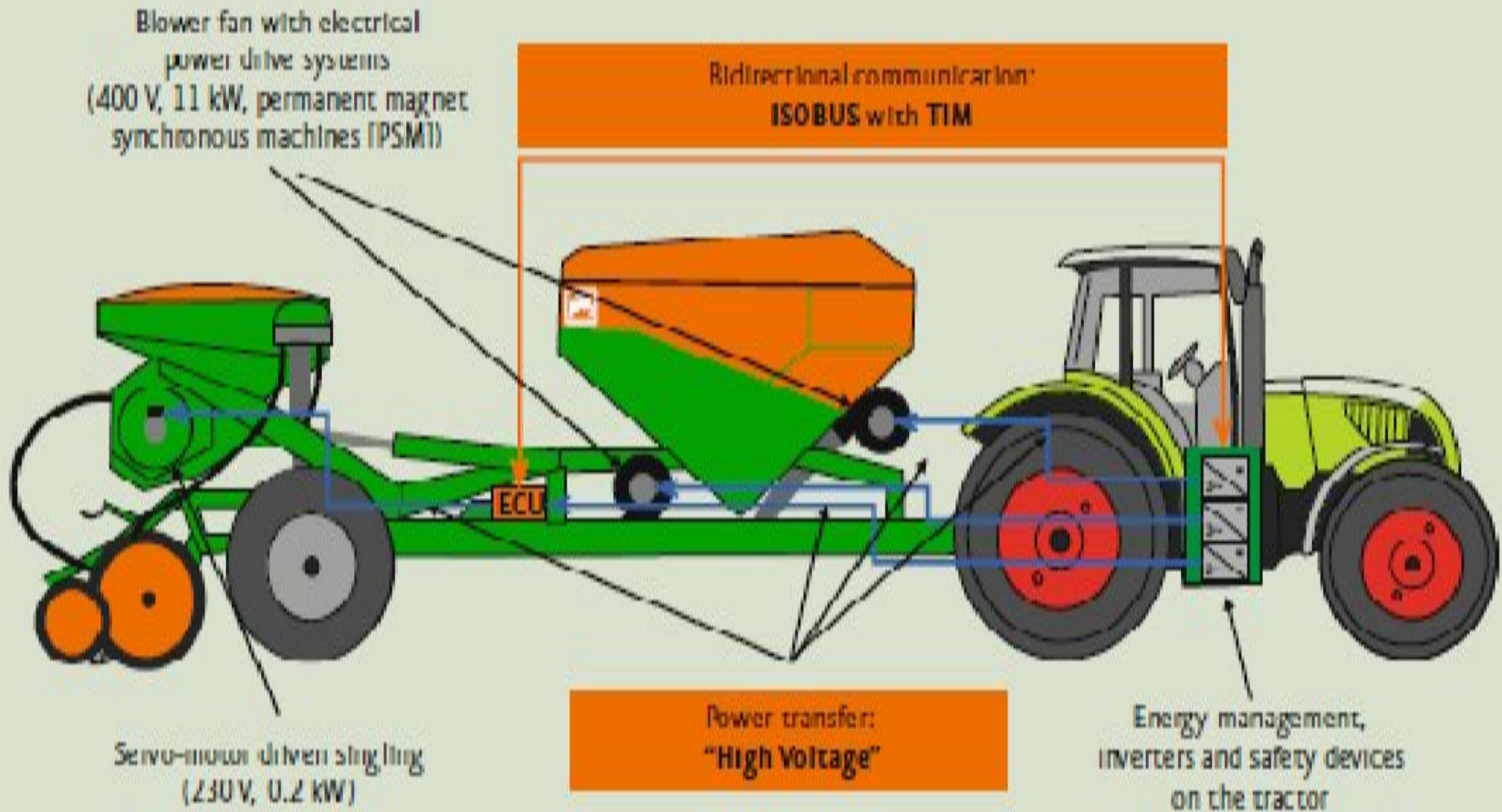

The scheme 2. EDX eSeed-electrical machine design

TIM- implementing Tractor-Implement-Management

Additional savings (of approx. 10 %) are realised because the seeder sends its demands for each individual operating parameter to the tractor. The implement controls the tractor and connects with it to become a modular selfpropelled vehicle – thus implementing Tractor-Implement-Management (TIM). So, for example, on the headland, the speed of the blower fan drive can be reduced automatically by the implement resulting, apart from additional fuel saving in a clear reduction of noise level.

Additional advantages:

•1

- Improved placement quality due to the higher dynamics of electrically powered drives during changing operational conditions (acceleration, braking).
- Limit values defined by the implement can protect the machine from damage by overload.
- Clearly higher dynamics and control quality for rotating drive systems on the machine.

•2

- High dynamic cut-out function for the protection of man and the environment on mounted implements is possible when critical situations are reached.
- Drive systems can be actively braked, so that in the case of an emergency, safety is achieved much quicker.
- Elimination of costly hydraulic components (control blocks, valves, oil coolers, etc.).

•3

- Reduction of the thermal demands on the oil reservoir in the tractor.
- No need for a permanently circulating oil flow.
- Improved comfort when coupling the implement (less hydraulic connections).

Thank you for your kind attention!

