

# Правила нанесения размеров

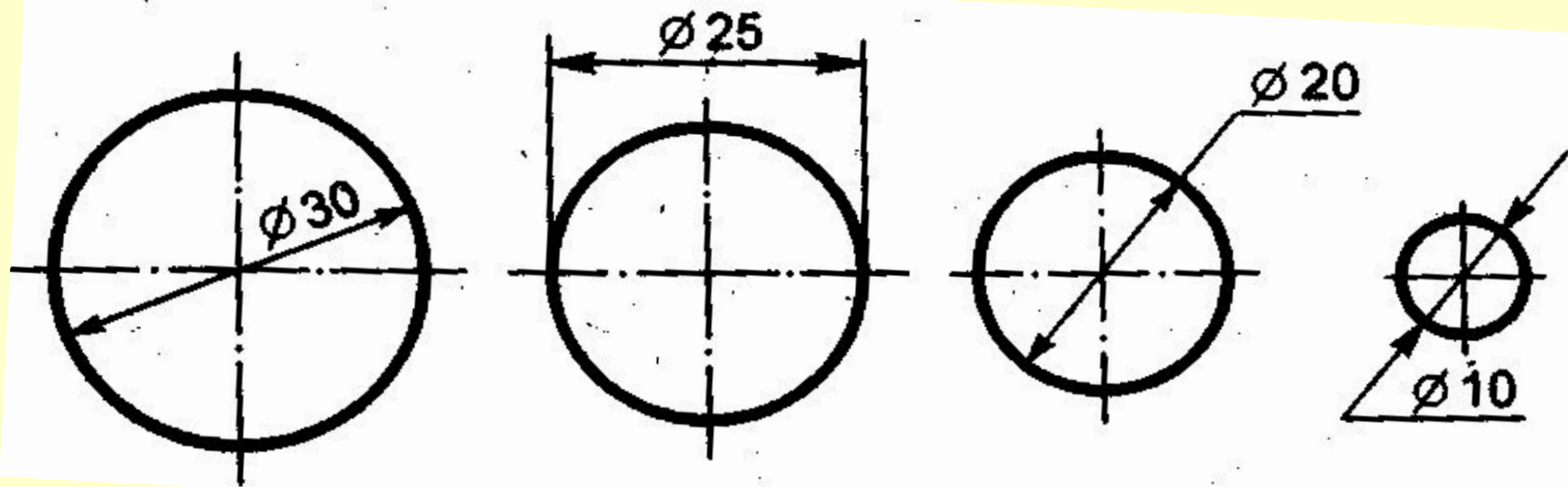

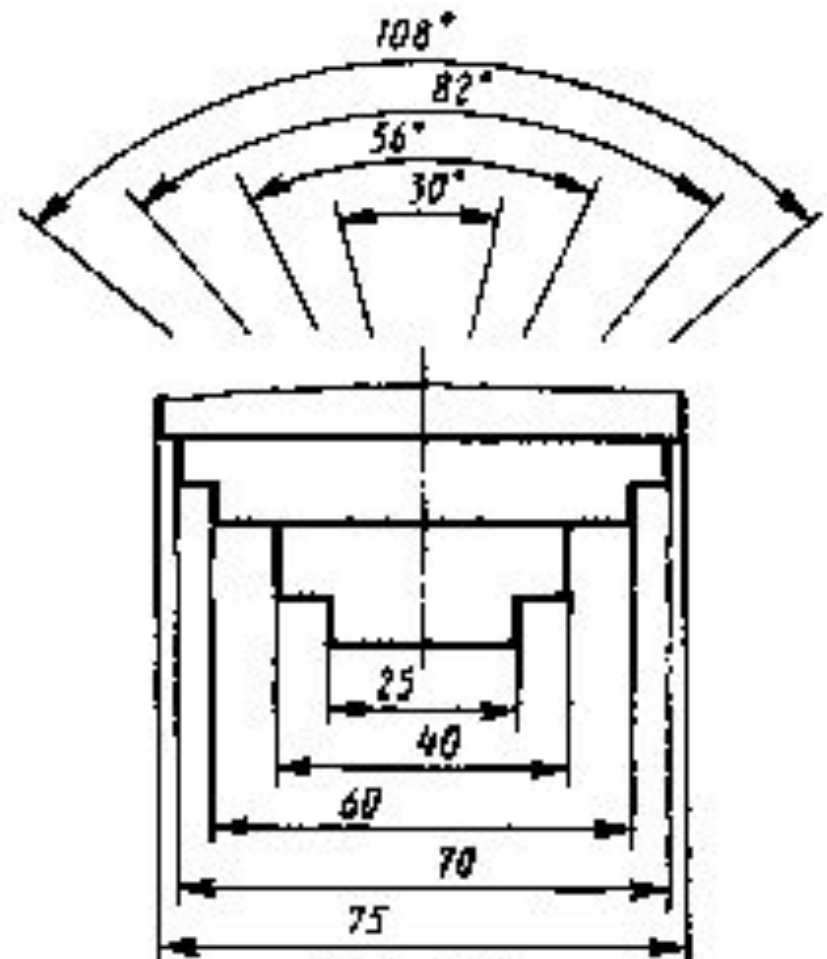

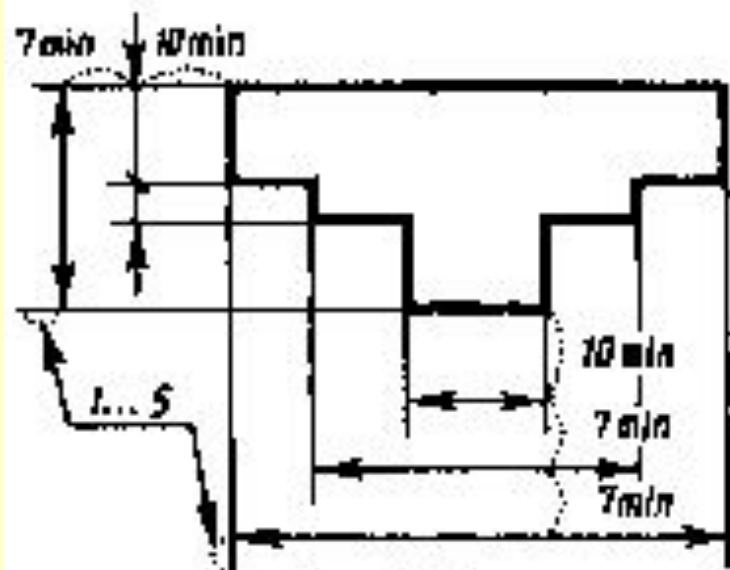

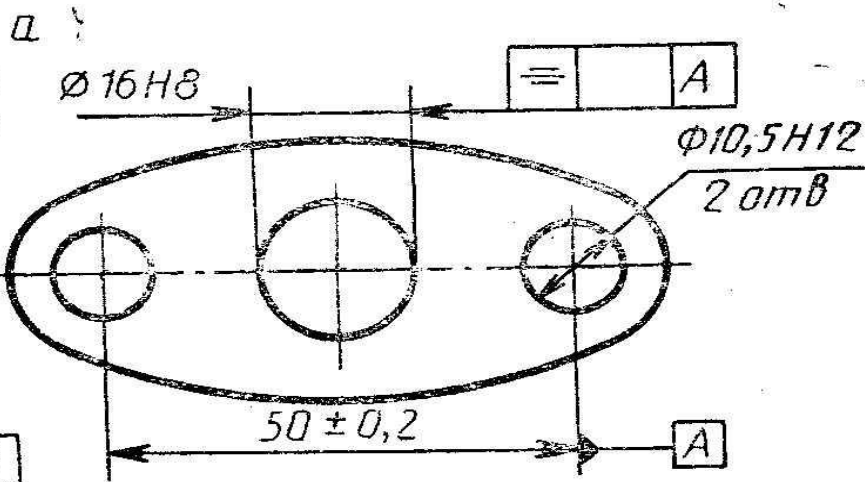
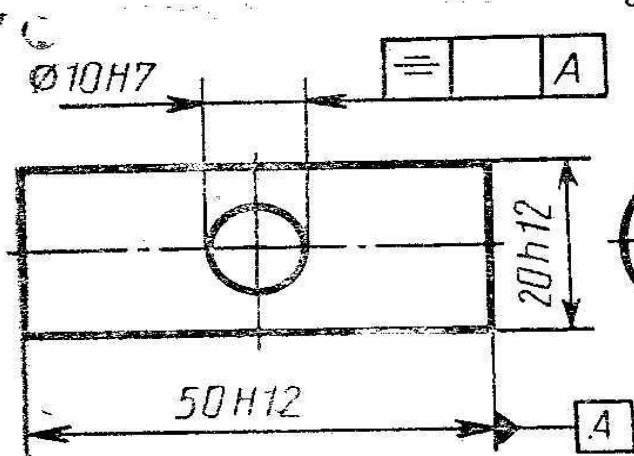
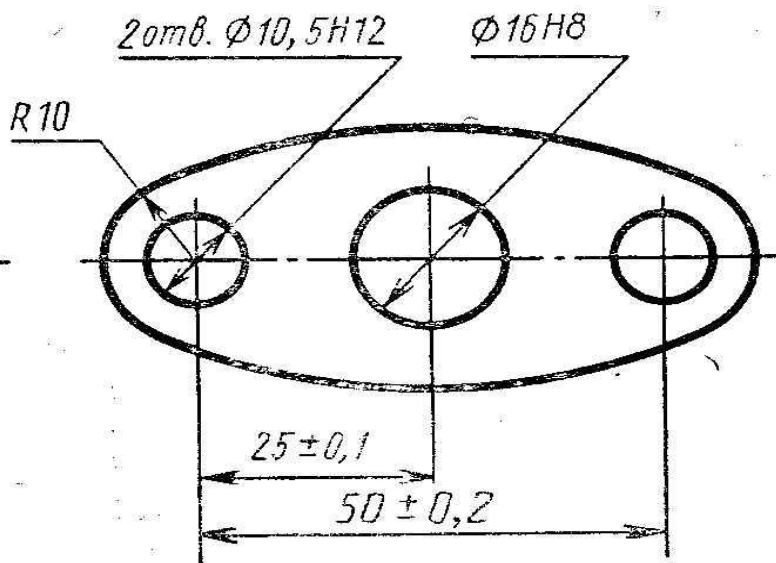
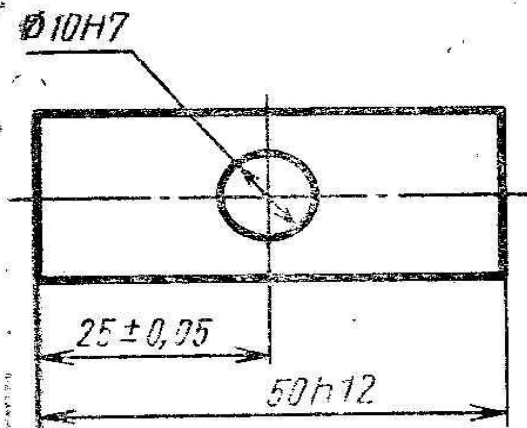

δ



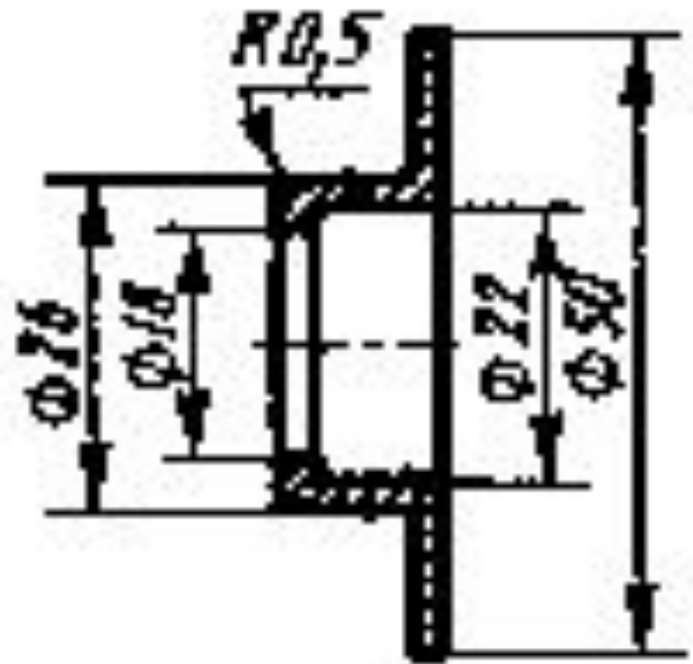
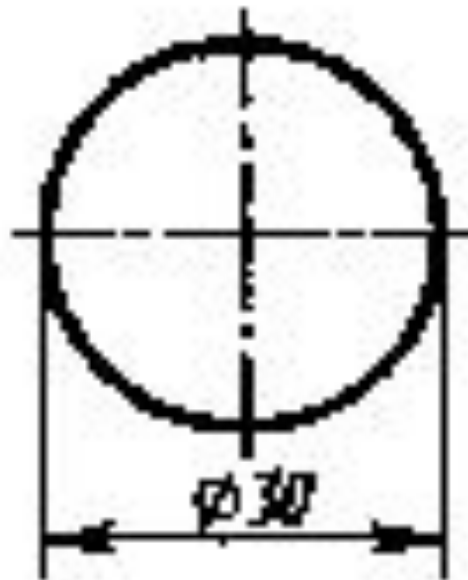

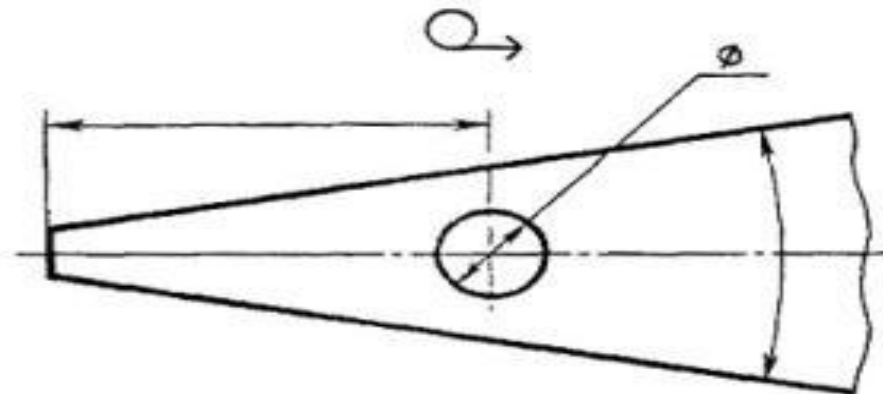
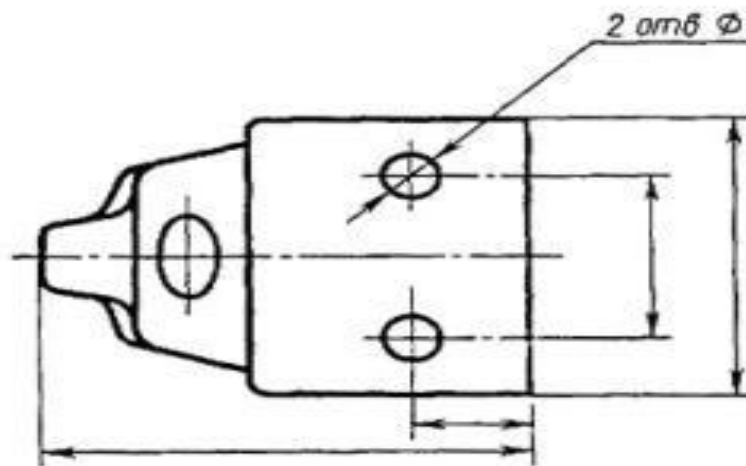
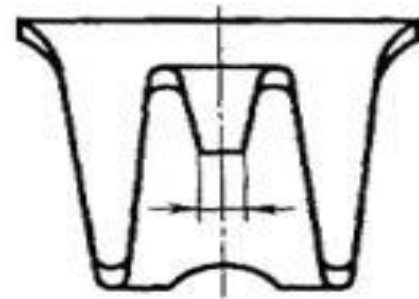
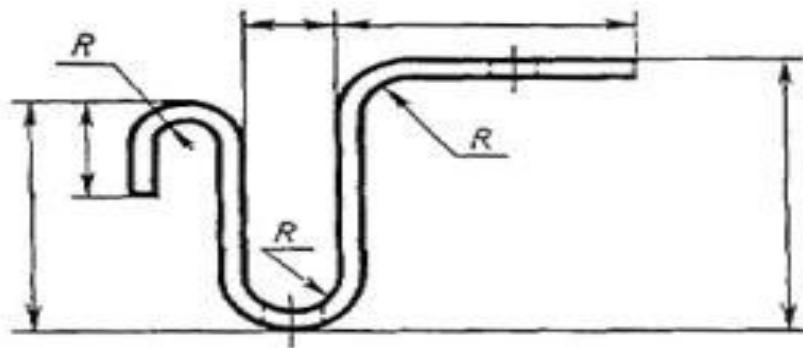



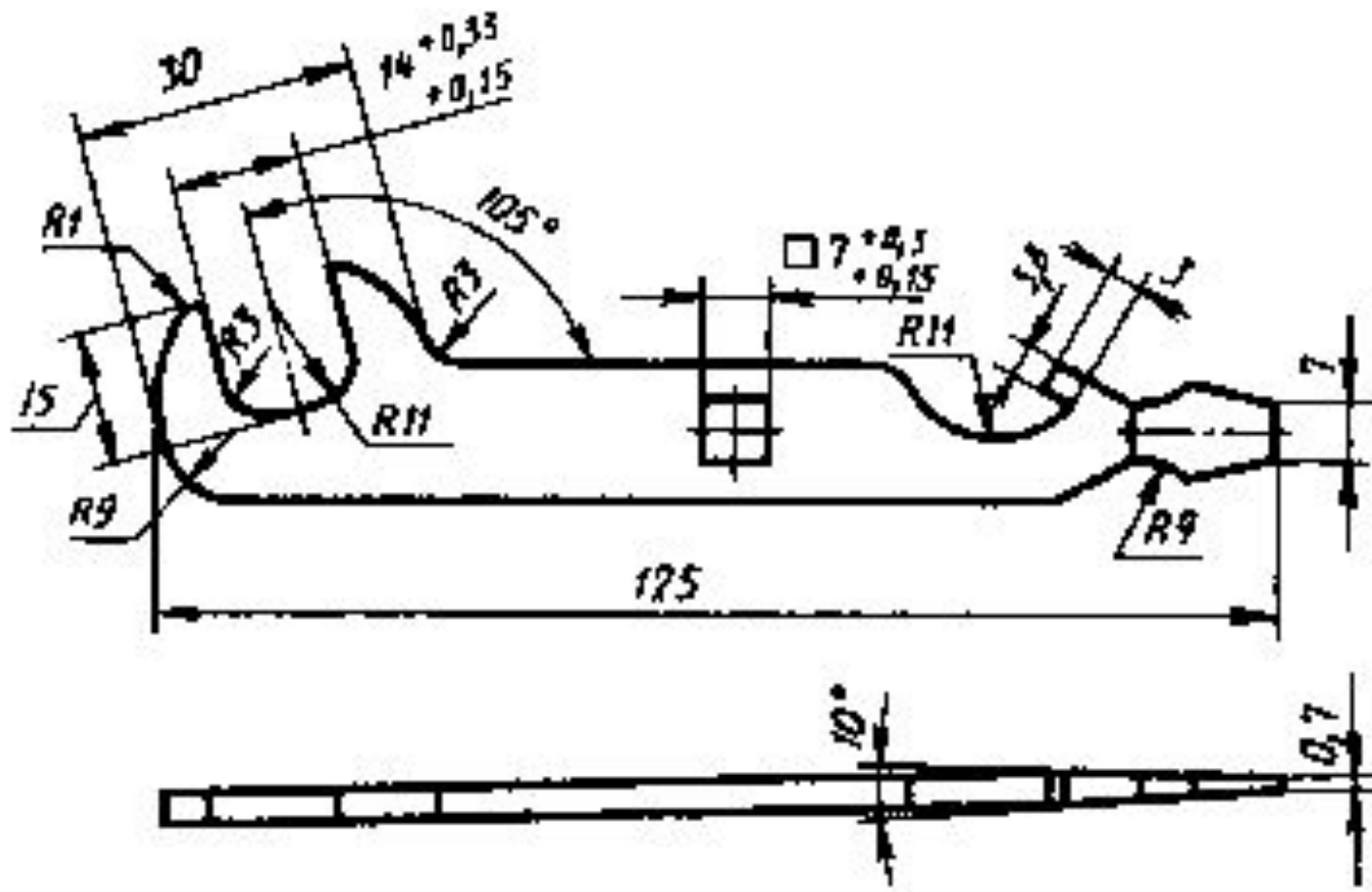

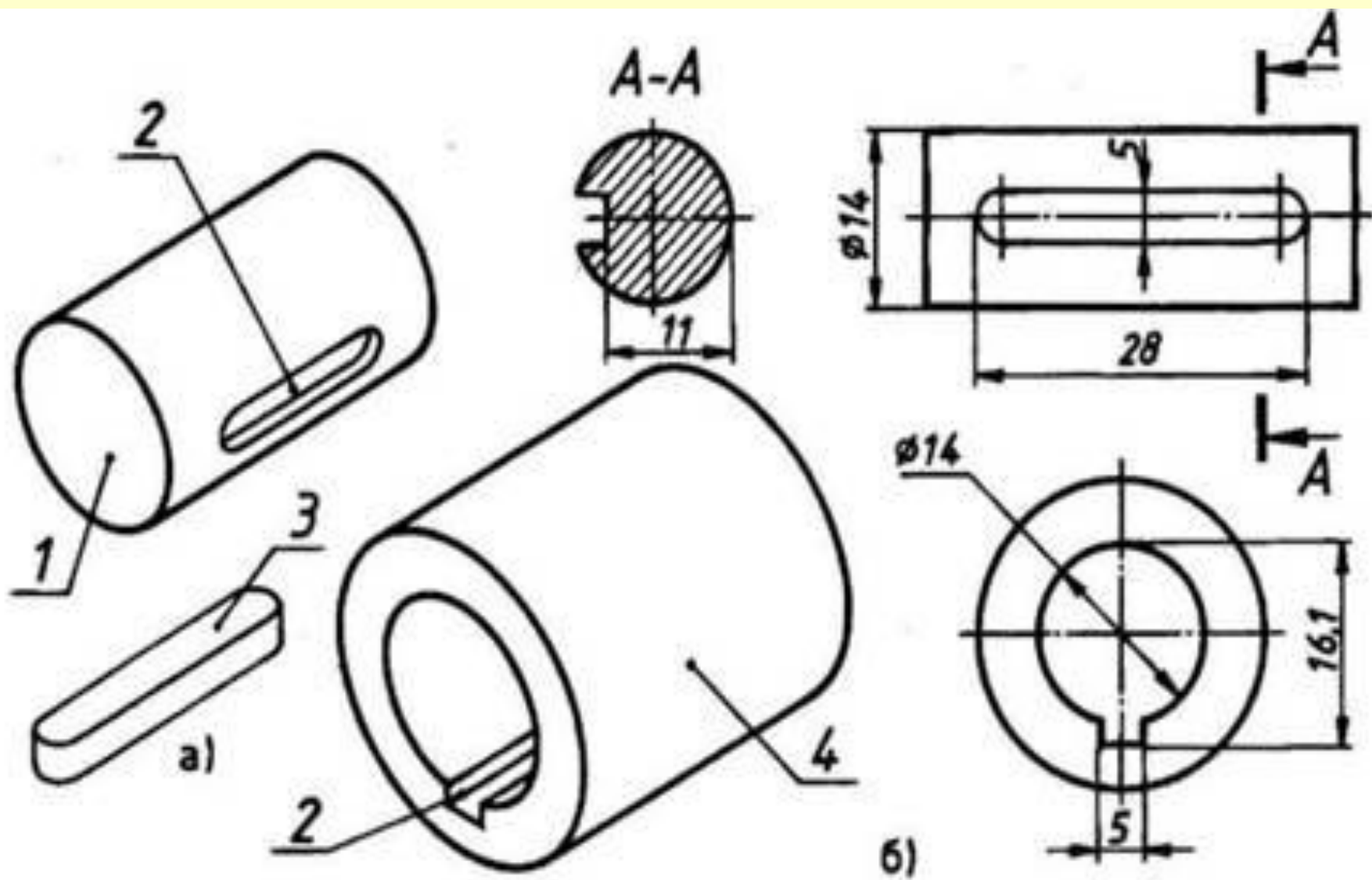

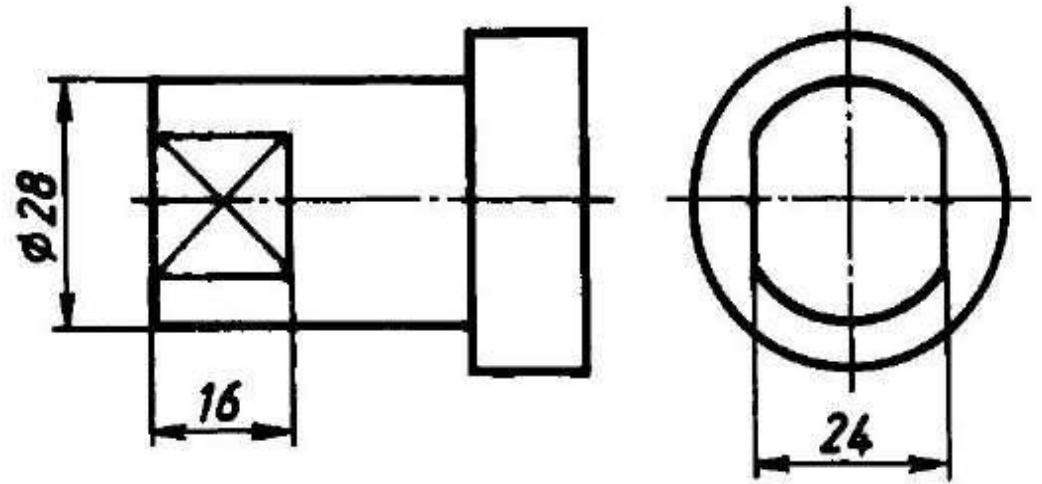
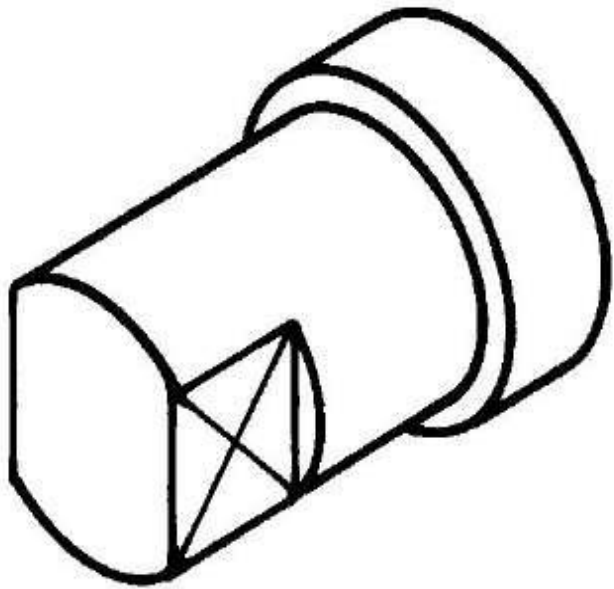

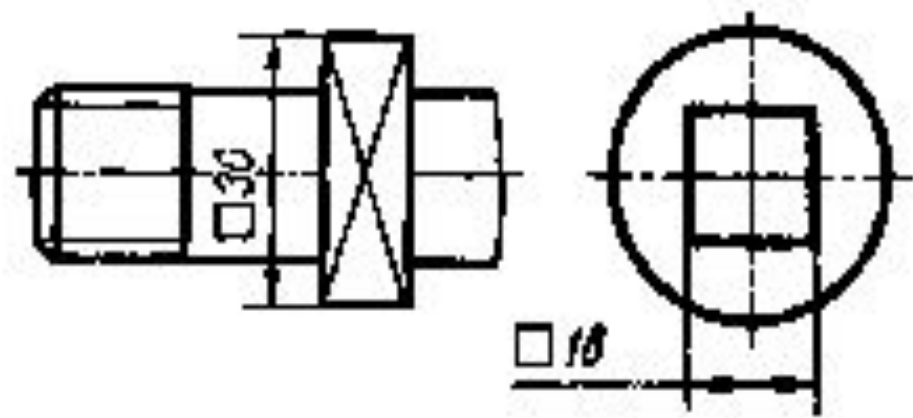
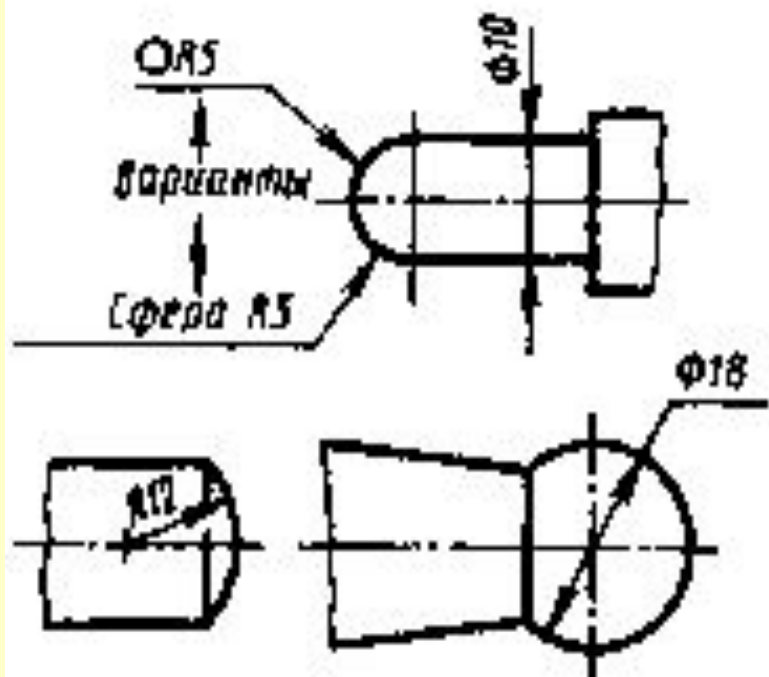

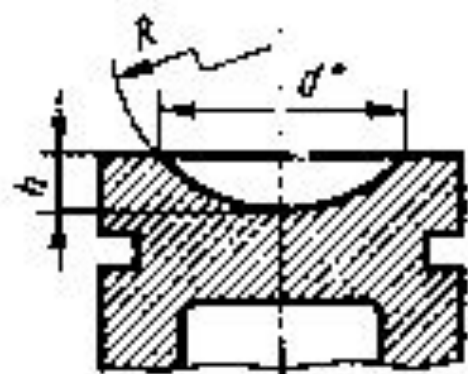

\* Размеры для справок

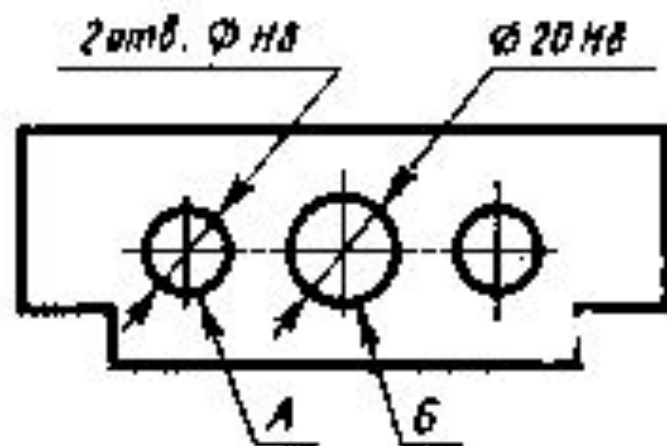
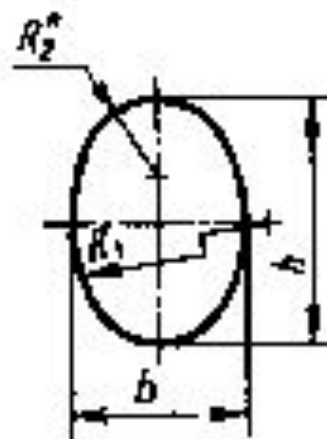

Допуск параллельности осей отв А и Б 0,05 мм

