

Helpdesk escalation path for H&M Latvia

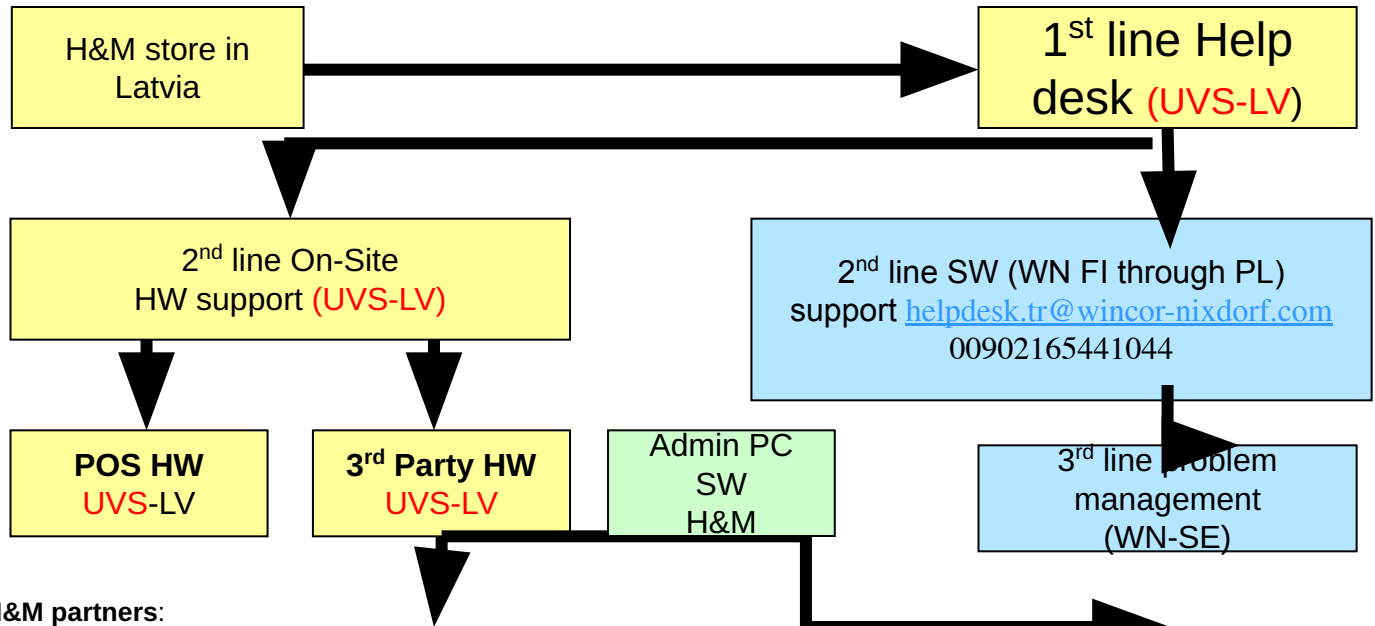

***) Note: UVS handles the Helpdesk but the calls from H&M will be answered with "Wincor Nixdorf Helpdesk"**